

# Product data sheet

Specifications



Monolithic tower lights, Harmony XVG, 60mm, red green, steady light, buzzer, aluminium tube mounting and L bracket, IP23, 24V AC/DC

XVGB2S

## Main

Range of product	Harmony XVG
Product or component type	Complete pre-wired monolithic tower light
Beacon or indicator bank unit type	2 illuminated units
Material	PC (UL94 V-2): globe ABS (UL94HB): tube body Aluminium: tube
Mounting diameter	60 mm
Component name	XVG
Device mounting	Tube with L bracket
Light source	LED steady red LED steady amber
Light block color	Red/green
Indicator bank base type	Base with integrated buzzer

## Complementary

Rated supply voltage	24 V AC/DC
Cable cross section	0.33 mm <sup>2</sup>
Discrete output type	PNP and NPN
[Uimp] rated impulse withstand voltage	0.5 kV
Current consumption	140 mA
Noise level	85 dB
Power consumption in W	3.1 W
Fundamental frequency	2.64 kHz
Net weight	0.43 kg

## Environment

Product certifications	CE EAC
Ambient air temperature for storage	-35...70 °C
Ambient air temperature for operation	-10...50 °C

IP degree of protection	IP23
-------------------------	------

## Packing Units

Unit Type of Package 1	PCE
Number of Units in Package 1	1
Package 1 Height	8.6 cm
Package 1 Width	14.3 cm
Package 1 Length	55.8 cm
Package 1 Weight	625.0 g
Unit Type of Package 2	S04
Number of Units in Package 2	5
Package 2 Height	30 cm
Package 2 Width	40 cm
Package 2 Length	60 cm
Package 2 Weight	3.2 kg

## Offer Sustainability

Sustainable offer status	Green Premium product
REACH Regulation	<a href="#">REACH Declaration</a>
EU RoHS Directive	Pro-active compliance (Product out of EU RoHS legal scope) <a href="#">EU RoHS Declaration</a>
Mercury free	Yes
China RoHS Regulation	<a href="#">China RoHS declaration</a>
RoHS exemption information	<a href="#">Yes</a>
Environmental Disclosure	<a href="#">Product Environmental Profile</a>
Circularity Profile	<a href="#">End of Life Information</a>
California proposition 65	WARNING: This product can expose you to chemicals including: Lead and lead compounds, which is known to the State of California to cause cancer and birth defects or other reproductive harm. For more information go to <a href="http://www.P65Warnings.ca.gov">www.P65Warnings.ca.gov</a>

## Contractual warranty

Warranty	18 months
----------	-----------

Dimensions

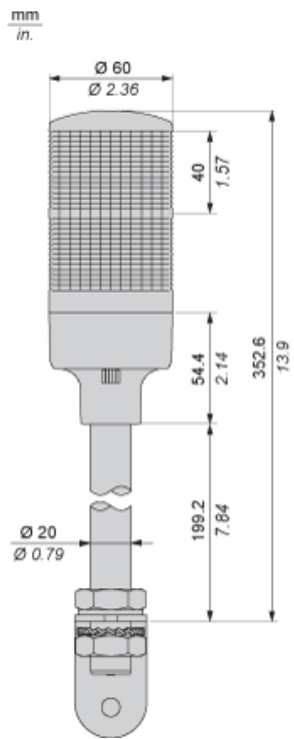

Mounting

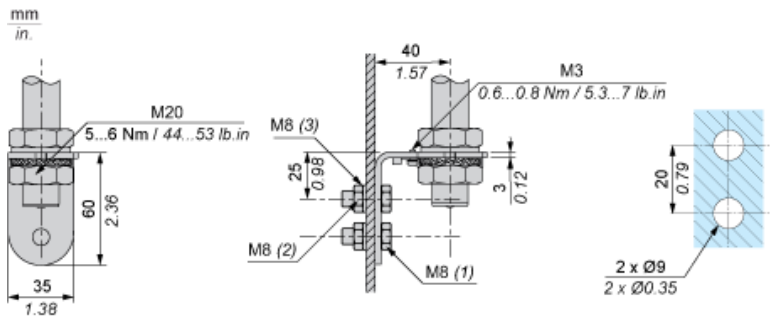

- (1) Thickness +10 mm/0.39 in
- (2) Hexagon Nut
- (3) Washer

**Wiring**

---

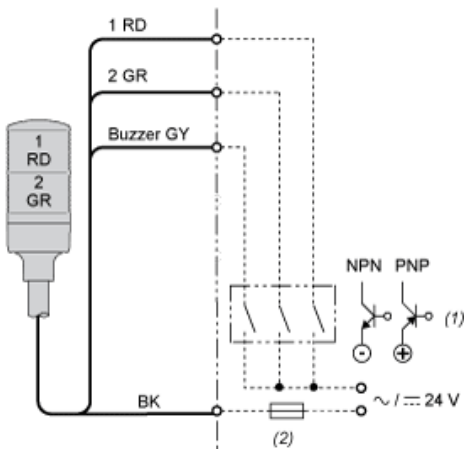

- (1) "ON" for lighting and/or applying continuous sound.
  - (2) Fuse (rated current: 0.5 A)
- RD :** Red  
**GR :** Green  
**GY :** Grey  
**BK :** Black

**Recommended replacement(s)**