



RVT3.5B320240CNWC81

LCD TFT Datasheet

Rev.1.3
2015-06-12

ITEM	CONTENTS	UNIT
LCD Type	TFT/Transmissive/Normally white	/
Size	3.5	Inch
Viewing Direction	12:00 (without image inversion)	O' Clock
Gray Scale Inversion Direction	6:00	O' Clock
LCM (W × H × D)	76.90 x 63.90 x 7.95	mm ³
Active Area (W × H)	70.08 × 52.56	mm ²
Dot Pitch (W × H)	0.73 × 0.219	mm ²
Number Of Dots	320 (RGB) × 240	/
Controller IC	FT801	/
Backlight Type	6 LEDs	/
Surface Luminance	480	cd/m ²
Interface Type	SPI/I2C	/
Color Depth	262k	/
Pixel Arrangement	RGB Vertical Stripe	/
Surface Treatment	Clear	/
Input Voltage	3.3	V
With/Without TSP	Projected Capacitive Touch Panel	/
Weight	56	g

Note 1: RoHS compliant

Note 2: LCM weight tolerance: ± 5%.

REVISION RECORD

REVNO.	REVDATE	CONTENTS	REMARKS
1.0	2014-10-27	Initial Release	
1.1	2015-01-07	Update surface luminance, update LED lifetime, update response time, update absolute maximum supply voltage	
1.2	2015-02-24	Update mode select information, thickness, update Touch Panel Ink View Area dimensions	
1.3	2014-10-27	Update surface treatment	

CONTENTS

REVISION RECORD.....	2
CONTENTS	2
1. MODULE CLASSIFICATION INFORMATION	3
2. MODULE DRAWING.....	4
3. ABSOLUTE MAXIMUM RATINGS.....	5
4. ELECTRICAL CHARACTERISTICS.....	5
5. ELECTRO-OPTICAL CHARACTERISTICS	5
6. INTERFACE DESCRIPTION	7
7. FT801 CONTROLLER SPECIFICATIONS	8
7.1. Serial host interface.....	8
7.2. Block Diagram.....	9
7.3. Host interface SPI mode 0	9
7.4. Backlight driver block diagram	9
8. LCD TIMING CHARACTERISTICS	10
8.1. Timing Chart	10
8.2. 24 Bit RGB Mode for 320 x RGB x 240.....	11
9. CAPACITIVE TOUCH SCREEN PANEL SPECIFICATIONS	12
9.1. Mechanical characteristics	12
9.2. Electrical characteristics	12
10. RELIABILITY TEST	13
11. LEGAL INFORMATION.....	14

1. MODULE CLASSIFICATION INFORMATION

RV	T	3.5	B	320240	C	N	W	C	81
1.	2.	3.	4.	5.	6.	7.	8.	9.	10.

1.	BRAND	RV – Riverdi
2.	PRODUCT TYPE	T – TFT Standard F – TFT Custom
3.	DISPLAY SIZE	3.5 – 3.5” 4.3 – 4.3” 5.7 – 5.7” 7.0 – 7.0”
4.	MODEL SERIAL NO.	B (A-Z)
5.	RESOLUTION	320240 – 320x240 px 480272 – 480x272 px 800480 – 800x480 px
6.	INTERFACE	T – TFT LCD, RGB L – TFT LCD, LVDS C – TFT + Controller
7.	FRAME	N – No Frame F – Mounting Frame
8.	BACKLIGHT TYPE	W – LED White
9.	TOUCH PANEL	N – No Touch Panel R – Resistive Touch Panel C – Capacitive Touch Panel
10.	VERSION	81 (00-99)

PIN	DESC
1	VDD
2	GND
3	SPI_SCLK/ I2C_SCL
4	MISO/I2C_SDA
5	MOSI/I2C_SA0
6	CS/I2C_SA1
7	INT
8	PD
9	MODE
10	AUDIO_OUT
11	NC
12	NC
13	NC
14	NC
15	NC
16	NC
17	BLVDD
18	BLVDD
19	BLGND
20	BLGND

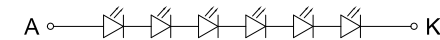
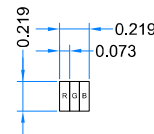
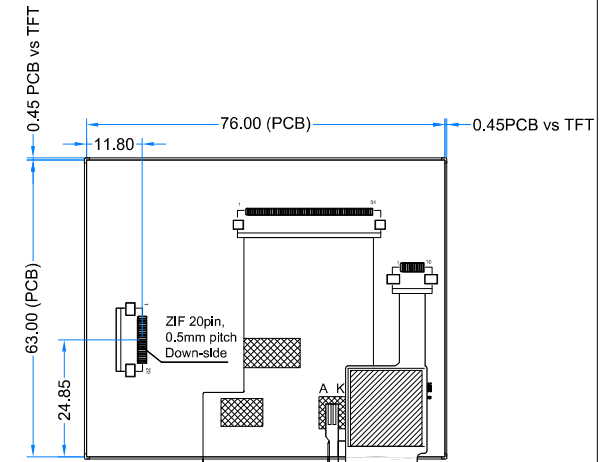
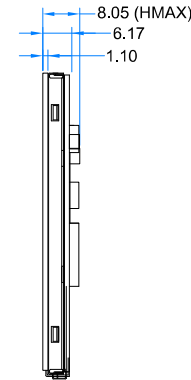
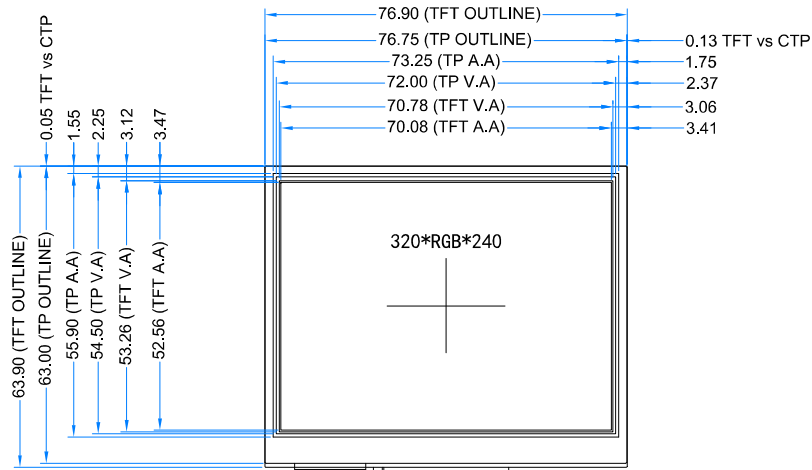

INTERNAL BACKLIGHT LED CONNECTION

NOTES:

1. DISPLAY TYPE: TFT, TRANSMISSIVE, NORMALLY WHITE
2. OPERATION VOLTAGE: VDD=3.3V
3. VIEWING DIRECTION: 12 O'CLOCK
4. IC CONTROLLER: FT801
5. OPERATING TEMP.: -20°C ~ 70°C
6. STORAGE TEMP.: -30°C ~ 80°C
7. LED BACKLIGHT: 6-LED WHITE, BUILT-IN INVERTER
8. SURFACE LUMINANCE: 480 cd/m²
9. GENERAL TOLERANCE: ±0.2
10. RoHS COMPLIANT
11. BLGND internally connected to GND

CUSTOMER APVL		DATE	2014-12-23
DRAWN	SCALE	TITLE	
DFTG CHK	UNIT	RVT3.5B320240CNWC81	
ENGR CHK	mm	MODEL	
APPROVAL		DWG NO	
		PAGE	
		1/1	

3. ABSOLUTE MAXIMUM RATINGS

PARAMETER	SYMBOL	MIN	MAX	UNIT
Supply Voltage For Logic (VDD pin)	VDD	0	3.7	V
Supply Voltage For Logic (BLVDD pins)	BLVDD	0	7.0	V
Input Voltage For Logic	VIN	GND	VDD	V
Operating Temperature	T _{OP}	-20	70	°C
Storage Temperature	T _{ST}	-30	80	°C
Humidity	RH	-	90%(Max 60°C)	RH

4. ELECTRICAL CHARACTERISTICS

PARAMETER	SYMBOL	MIN	TYP	MAX	UNIT	NOTES
Supply Voltage For Module	VDD	3.0	3.3	3.6	V	
Input Voltage for LED Inverter	BLVDD	2.8	3.3	5.5	V	
Input Current (Exclude LED Backlight)	IDD	-	65	82	mA	VDD = 3.3V
LED Backlight Current	IDD _{backlight}		150	187	mA	BLVDD=3.3V
LED Backlight Current	IDD _{backlight}		93	117	mA	BLVDD=5V
Total Input Current (Include LED Backlight 100%)	IDD _{total}	-	215	269	mA	BLVDD=3.3V
Input Voltage ' H ' level	V _{IH}	0.7VDD	-	VDD	V	
Input Voltage ' L ' level	V _{IL}	0	-	0.2VDD	V	
LED Life Time	-	40000	50000	-	Hrs	Note 1

Note 1: The LED life time is defined as the module brightness decrease to 50% original brightness at Ta=25°C.

Note 2: Voltage Inverter ground (BLGND) is internally connected to GND

5. ELECTRO-OPTICAL CHARACTERISTICS

ITEM	SYMBOL	CONDITION	MIN	TYP	MAX	UNIT	REMARK	NOTE
Response Time	Tr+Tf	θ=0° φ=0° Ta=25°C	-	25	30	ms	Figure 1	4
Contrast Ratio	Cr		-	350	-	---	Figure 2	1
Luminance Uniformity	δ WHITE		75	80	-	%	Figure 2	3
Surface Luminance	Lv		-	480	-	cd/m ²	Figure 2	2
Viewing Angle Range	θ	φ = 90°	30	40	-	deg	Figure 3	6
		φ = 270°	50	60	-	deg	Figure 3	
		φ = 0°	50	60	-	deg	Figure 3	
		φ = 180°	50	60	-	deg	Figure 3	
CIE (x, y) Chromaticity	Red	θ=0° φ=0° Ta=25°C	x	0.574	0.624	0.674	Figure 2	5
			y	0.318	0.368	0.418		
	Green		x	0.300	0.350	0.400		
			y	0.500	0.550	0.600		
	Blue		x	0.093	0.143	0.193		
			y	0.069	0.119	0.169		
	White		x	0.260	0.310	0.360		
			y	0.283	0.333	0.383		
NTSC	-	-	-	50	-	%	-	

Note 1. Contrast Ratio(CR) is defined mathematically as below, for more information see Figure 1.

$$\text{Contrast Ratio} = \frac{\text{Average Surface Luminance with all white pixels (P1, P2, P3, P4, P5)}}{\text{Average Surface Luminance with all black pixels (P1, P2, P3, P4, P5)}}$$

Note 2. Surface luminance is the LCD surface from the surface with all pixels displaying white. For more information see Figure 2.

L_v = Average Surface Luminance with all white pixels (P1, P2, P3, P4, P5)

Note 3. The uniformity in surface luminance δ WHITE is determined by measuring luminance at each test position 1 through 5, and then dividing the maximum luminance of 5 points luminance by minimum luminance of 5 points luminance. For more information see Figure 2.

$$\delta \text{ WHITE} = \frac{\text{Minimum Surface Luminance with all white pixels (P1, P2, P3, P4, P5)}}{\text{Maximum Surface Luminance with all white pixels (P1, P2, P3, P4, P5)}}$$

Note 4. Response time is the time required for the display to transition from white to black (Rise Time, T_r) and from black to white (Decay Time, T_f). For additional information see Figure 1. The test equipment is Autronic-Melchers's ConoScope series.

Note 5. CIE (x, y) chromaticity, the x, y value is determined by measuring luminance at each test position 1 through 5, and then make average value.

Note 6. Viewing angle is the angle at which the contrast ratio is greater than 2. For TFT module the contrast ratio is greater than 10. The angles are determined for the horizontal or x axis and the vertical or y axis with respect to the z axis which is normal to the LCD surface. For more information see Figure 3.

Note 7. For viewing angle and response time testing, the testing data is based on Autronic-Melchers's ConoScope series. Instruments for Contrast Ratio, Surface Luminance, Luminance Uniformity, CIE the test data is based on TOPCON's BM-5 photo detector.

Note 8. For TFT module, gray scale reverse occurs in the direction of panel viewing angle.

Figure 1. The definition of response time

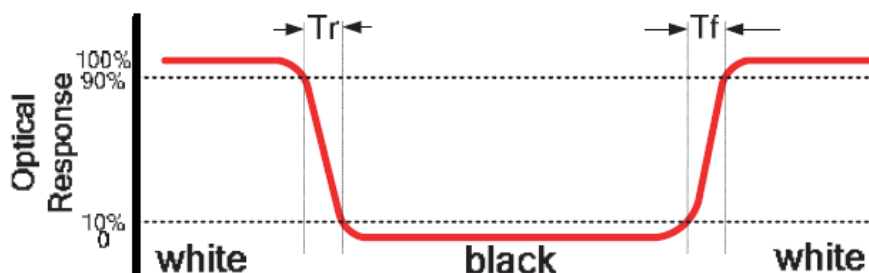

Figure 2. Measuring method for Contrast ratio, surface luminance, Luminance uniformity, CIE (x, y) chromaticity

A : 5 mm
B : 5 mm
H, V : Active Area
Light spot size $\varnothing=5\text{mm}$, 500mm distance from the LCD surface to detector lens
measurement instrument is TOPCON's luminance meter BM-5

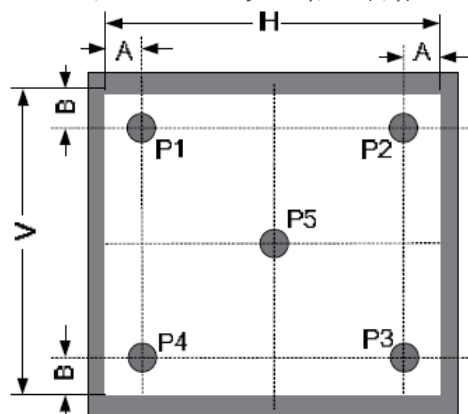
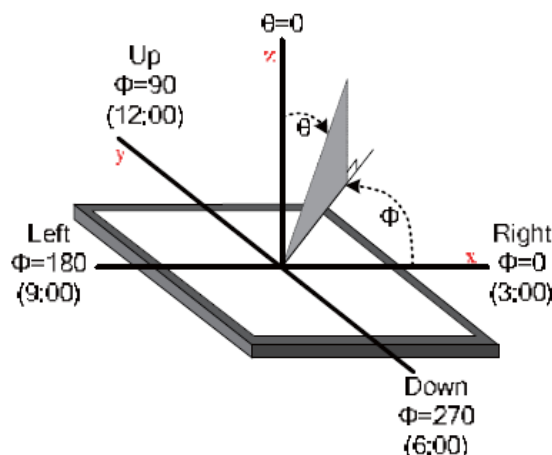

Figure 3. The definition of viewing angle



6. INTERFACE DESCRIPTION

PIN NO.	SYMBOL	DESCRIPTION
1	VDD	Power Supply
2	GND	Ground
3	SPI_SCLK/ I2C_SCL	SPI SCK Signal / I2C SCL Signal, Pulled Up Inside Display by 47k Resistor
4	MISO/ I2C_SDA	SPI MISO Signal / I2C SDA Signal, Pulled Up Inside Display by 47k Resistor
5	MOSI/ I2C_SA0	SPI MOSI Signal / I2C Slave Address Bit 0, Pulled Up Inside Display by 47k Resistor
6	CS/I2C_SA1	SPI Chip Select Signal / I2C Slave Address Bit 1, Pulled Up Inside Display by 47k Resistor
7	INT	Interrupt Signal, Active Low, Pulled Up Inside Display by 47k Resistor
8	PD	Power Down Signal, Active Low, Pulled Up Inside Display by 47k Resistor
9	MODE	Host Interface SPI(Pull Low) or I2C(Pull Up) Mode Select Input, Internally 10k Pull DOWN
10	AUDIO_OUT	Audio Out Signal
11	NC	Not Connected
12	NC	Not Connected
13	NC	Not Connected

14	NC	Not Connected
15	NC	Not Connected
16	NC	Not Connected
17	BLVDD	Backlight Power Supply, Can Be Connected to VDD
18	BLVDD	Backlight Power Supply, Can Be Connected to VDD
19	BLGND	Backlight Ground, Internally connected to GND
20	BLGND	Backlight Ground, Internally connected to GND

7. FT801 CONTROLLER SPECIFICATIONS

FT801 or EVE (Embedded Video Engine) simplifies the system architecture for advanced human machine interfaces (HMIs) by providing functionality for display, audio, and touch as well as an object oriented architecture approach that extends from display creation to the rendering of the graphics.

7.1. Serial host interface

Figure 4. SPI interface connection

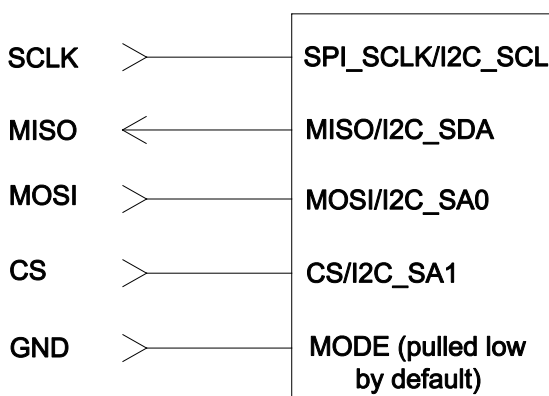
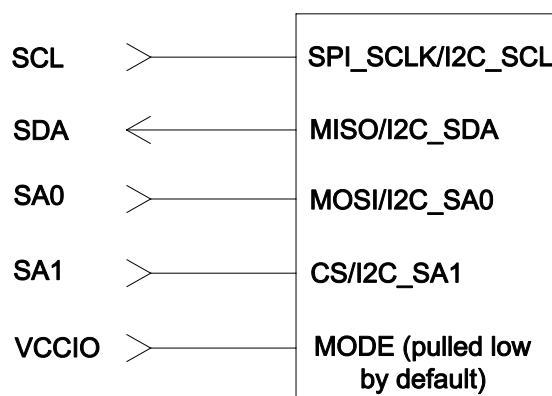

Figure 5. I2C interface connection



SPI Interface – the SPI slave interface operates up to 30MHz.

Only SPI mode 0 is supported. The SPI interface is selected by default (MODE pin is internally pulled low by 47k resistor).

I²C Interface – the I²C slave interface operates up to 3.4MHz, supporting standard-mode, fast-mode, fast-mode plus and high-speed mode.

The I²C device address is configurable between 20h to 23h depending on the I²C_SA[1:0] pin setting, i.e. the 7-bit I²C slave address is 0b'01000A1A0.

The I²C interface is selected when the MODE pin is tied to VDDIO.

7.2. Block Diagram

Figure 6. FT801 Block diagram

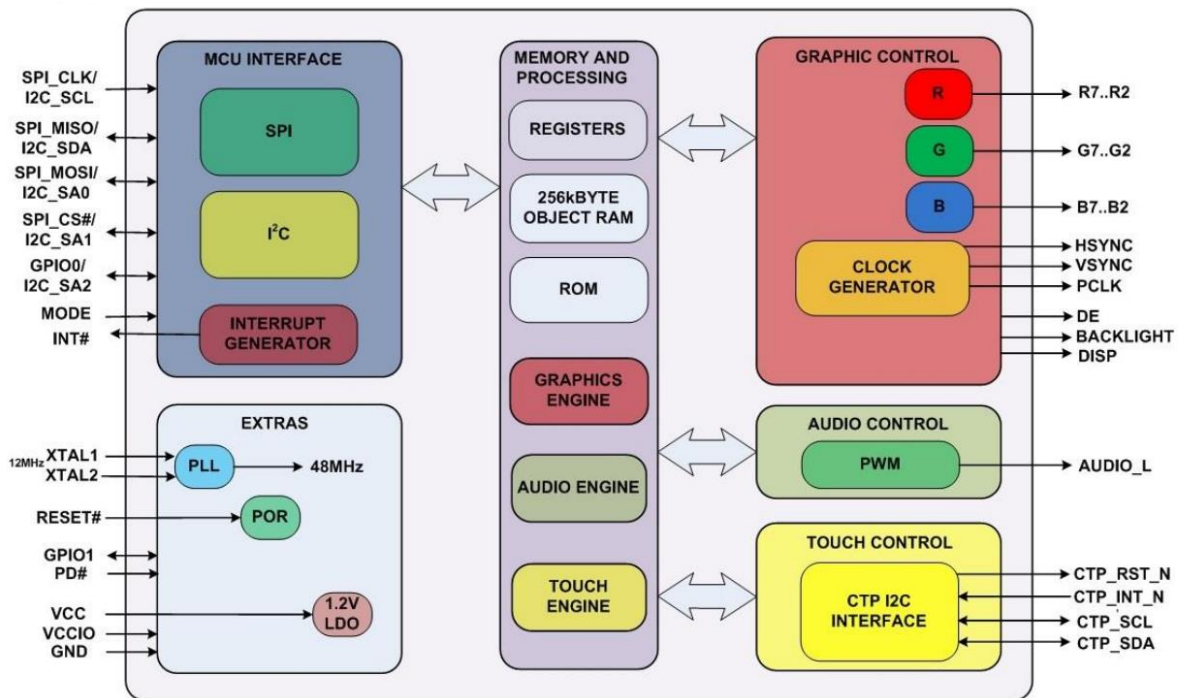

7.3. Host interface SPI mode 0

Figure 7. SPI timing diagram

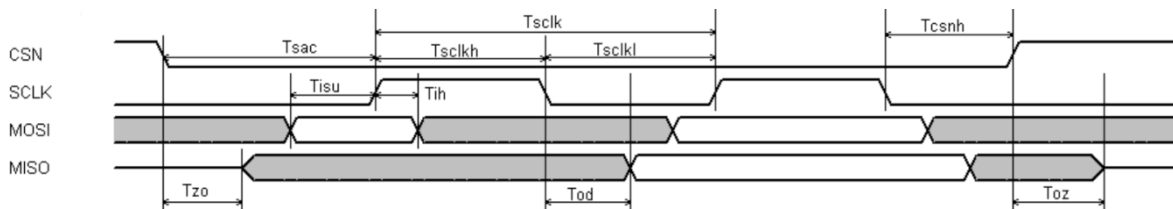

For more information about FT801 controller please go to official FT801 Datasheet.

http://www.ftdichip.com/Support/Documents/DataSheets/ICs/DS_FT801.pdf

7.4. Backlight driver block diagram

Backlight enable signal is internally connected to FT801 Backlight control pin. This pin is controlled by two FT801's registers. One of them specifies the PWM output frequency, second one specifies the duty cycle. Refer to FT801 datasheet for more information.

Figure 8. Backlight driver block diagram

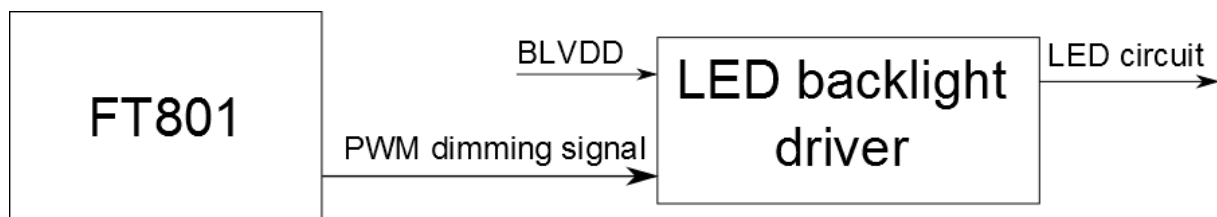

8. LCD TIMING CHARACTERISTICS

8.1. Timing Chart

Timing parameter (VDD=3.3V, GND=0V, Ta=25°C)

PARAMETER	SYMBOL	MIN	TYP	MAX	UNIT	CONDITION
CLK Clock Time	T_{clk}	$1/\text{Max}(F_{CLK})$	-	$1/\text{Min}(F_{CLK})$	ns	-
CLK Pulse Duty	T_{chwh}	40	50	60	%	T_{CLK}
HSYNC to CLK	T_{hc}	-	-	1	CLK	-
HSYNC Width	T_{hwh}	1	-	-	CLK	-
VSYNC Width	T_{vwh}	1	-	-	ns	-
HSYNC Period Time	T_h	60	63.56	67	ns	-
VSYNC Set-up Time	T_{vst}	12	-	-	ns	-
VSYNC Hold Time	T_{vhd}	12	-	-	ns	-
HSYNC Setup Time	T_{hst}	12	-	-	ns	-
HSYNC Hold Time	T_{hhd}	12	-	-	ns	-
Data Set-up Time	T_{dsu}	12	-	-	ns	D00~D23 to CLK
Data Hold Time	T_{dhd}	12	-	-	ns	D00~D23 to CLK
DEN Set-up Time	T_{esu}	12	-	-	ns	DEN to CLK

Figure 9. DE mode timing diagram

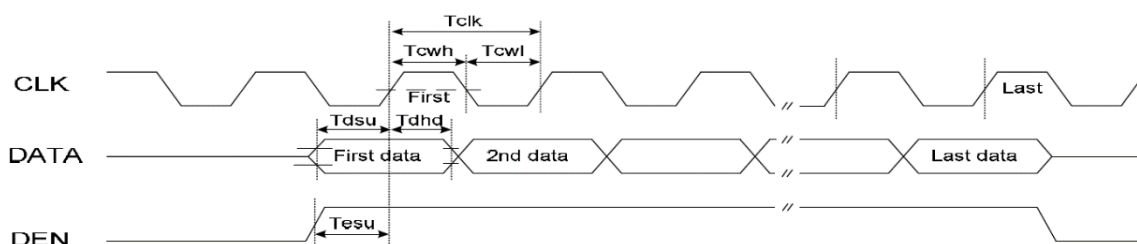

Figure 10. SYNC mode timing diagram

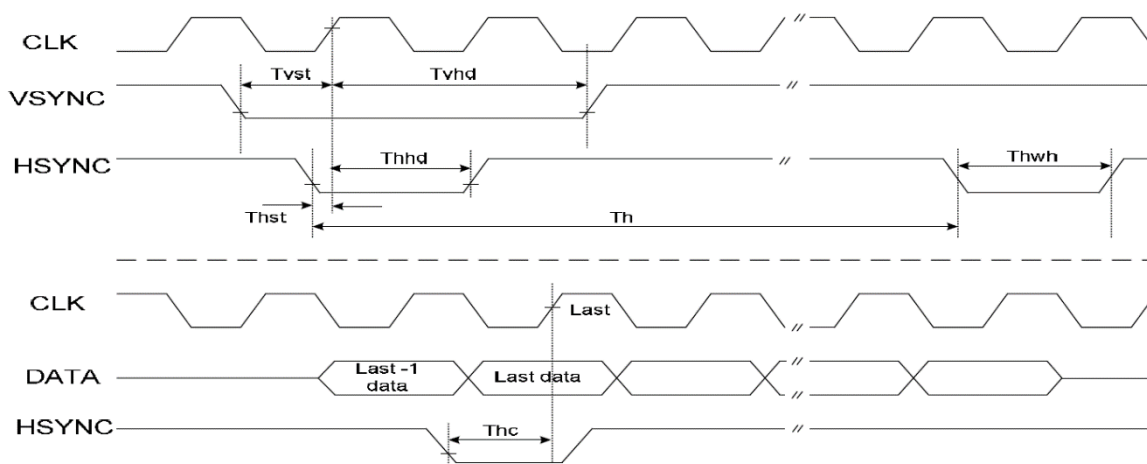
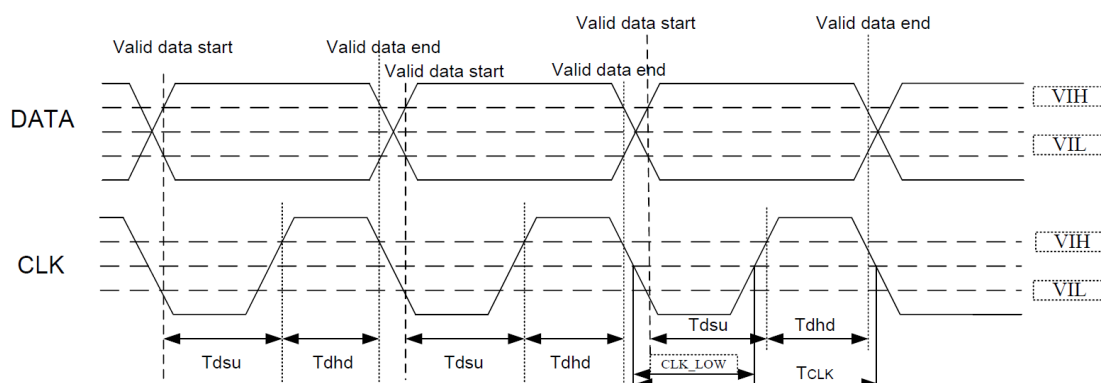

Figure 11. Timing diagram



8.2. 24 Bit RGB Mode for 320 x RGB x 240

PARAMETER	SYMBOL	MIN	TYP	MAX	UNIT	CONDITION
CLK Frequency	F_{clk}	7.0	8.0	9.0	MHz	VDD=3.0V~3.6V
CLK Cycle Time	T_{clk}	143	125	111	ns	-
CLK Pulse Duty	T_{cwh}	40	50	60	%	-
Time that HSYNC to 1st Data Input (NTSC)	T_{hs}	40	70	255	CLK	DDLY=70 Offset=0(fixed)

Figure 12. 24 bit RGB SYNC mode timing

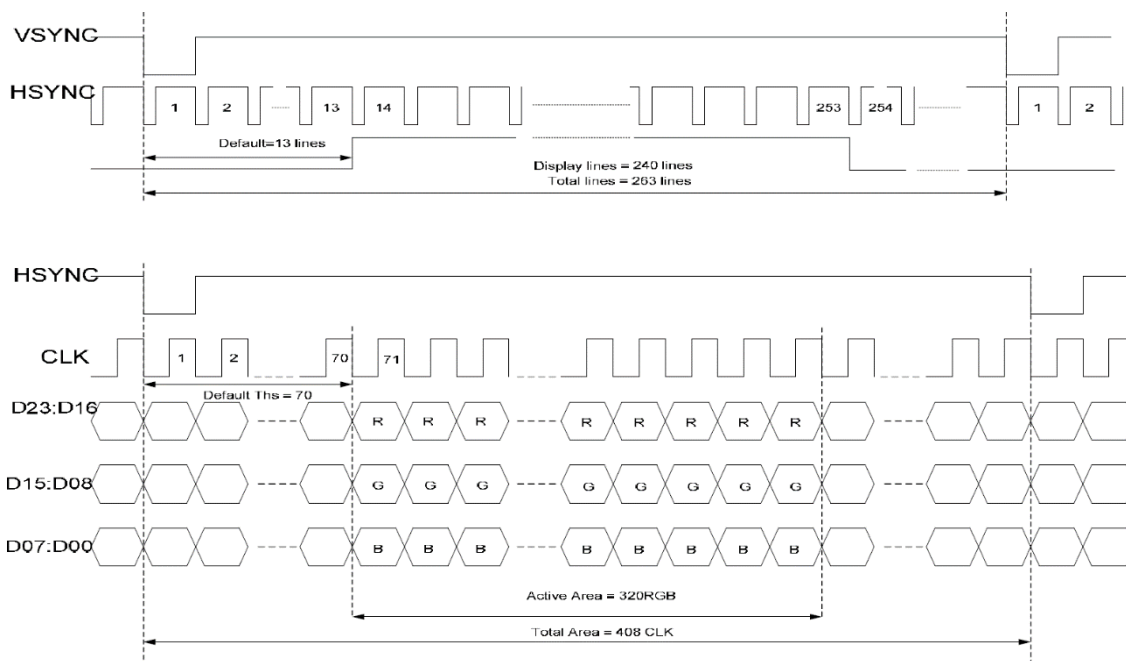

9. CAPACITIVE TOUCH SCREEN PANEL SPECIFICATIONS

Capacitive Touch Panel is directly connected to FT801 module. Therefore communication with Capacitive touch panel is simplified to read registers of FT801.

Figure 13. Capacitive Touch Panel Connection

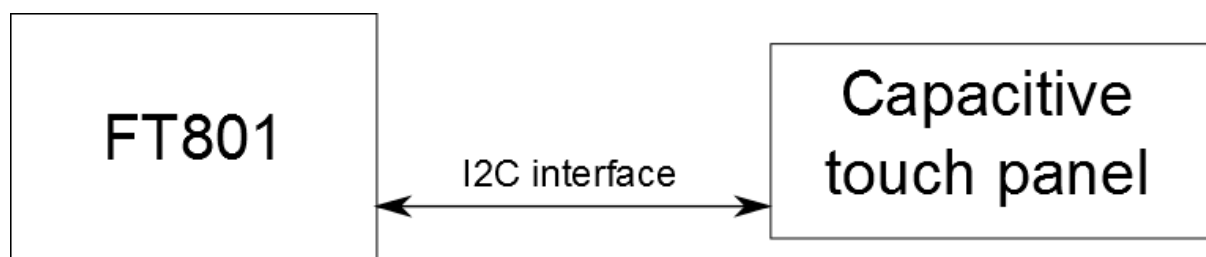

9.1. Mechanical characteristics

DESCRIPTION	INL SPECIFICATION	REMARK
Touch Panel Size	3.5 inch	
Outline Dimension (OD)	76.75 mm x 63.00mm	Cover Lens Outline
Product Thickness	1.26mm	
Glass Thickness	0.7 mm	
Ink View Area	72.00mm x 54.50mm	
Sensor Active Area	73.25mm x 55.90mm	
Input Method	5 Finger	
Activation Force	Touch	
Surface Hardness	≥7H	

9.2. Electrical characteristics

DESCRIPTION	SPECIFICATION
Operating Voltage	DC 2.8~3.6V
Power Consumption (IDD)	Active Mode
	Sleep Mode
Interface	I ² C
Linearity	<1.5%
Controller	FT5206
I2C address	0x38 (7 bit address)
Resolution	896*640

10. RELIABILITY TEST

NO.	TEST ITEM	TEST CONDITION	INSPECTION AFTER TEST
1	High Temperature Storage	80±2°C/240 hours	Inspection after 2~4 hours storage at room temperature, the sample shall be free from defects: <ol style="list-style-type: none"> 1. Air bubble in the LCD 2. Seal leak 3. Non-display 4. Missing segments 5. Glass crack 6. Current I_{dd} is twice higher than initial value 7. The surface shall be free from damage 8. Linearity must be no more than 1.5% by the linearity tester 9. The Electric characteristics requirements shall be satisfied
2	Low Temperature Storage	-30±2°C/240 hours	
3	High Temperature Operating	70±2°C/240 hours	
4	Low Temperature Operating	-20±2°C/240 hours	
5	Temperature Cycle	-30±2°C~25~70±2°C × 30 cycles	
6	Damp Proof Test	60°C ±5°C × 90%RH/160 hours	
7	Vibration Test	Frequency 10Hz~55Hz Stroke: 1.5mm Sweep: 10Hz~55Hz~10Hz 2 hours For each direction of X, Y, Z (6 hours for total)	
8	Mechanical Shock	60G 6ms, ± X, ± Y, ± Z 3 times for each direction	
9	Packing Drop Test	Height: 80 cm 1 corner, 3 edges, 6 surfaces	
10	Package Vibration Test	Random vibration: 0.015G ² /Hz from 5-200Hz -6dB/Octave from 200-500Hz 2 hours for each direction of X, Y, Z (6 hours for total)	
11	Electrostatic Discharge	Air: ±8KV 150pF/330Ω 5 times Contact: ±4KV 150pF/330Ω 5 times	
12	Hitting Test	1,000,000 times in the same point Hitting pad: tip R3.75mm, Silicone rubber, Hardness: 40deg. Load: 2.45N Hitting speed: Twice/sec Electric load: none Test area should be at 1.8mm inside of insulation.	
13	Pen Sliding Durability Test	100,000 times minimum Hitting pad: tip R0.8mm plastic pen Load: 1.47N Sliding speed: 60 mm/sec Electric load: none Test area should be at 1.8mm inside of insulation.	

Remark:

1. The test samples should be applied to only one test item.
2. Sample size for each test item is 5~10pcs.
3. For Damp Proof Test, Pure water(Resistance 10MΩ) should be used.
4. In case of malfunction defect caused by ESD damage, if it would be recovered to normal state after resetting, it would be judge as a good part.
5. EL evaluation should be excepted from reliability test with humidity and temperature: Some defects such as black spot/blemish can happen by natural chemical reaction with humidity and Fluorescence EL has.
6. Failure Judgment Criterion: Basic Specification, Electrical Characteristic, Mechanical Characteristic, Optical Characteristic.

11. LEGAL INFORMATION

Riverdi makes no warranty, either expressed or implied with respect to any product, and specifically disclaims all other warranties, including, without limitation, warranties for merchantability, non-infringement and fitness for any particular purpose. Information about device are the property of Riverdi and may be the subject of patents pending or granted. It is not allowed to copy or disclosed this document without prior written permission.

Riverdi endeavors to ensure that the all contained information in this document are correct but does not accept liability for any error or omission. Riverdi products are in developing process and published information may be not up to date. Riverdi reserves the right to update and makes changes to Specifications or written material without prior notice at any time. It is important to check the current position with Riverdi.

Images and graphics used in this document are only for illustrative the purpose. All images and graphics are possible to be displayed on the range products of Riverdi, however the quality may vary. Riverdi is no liable to the buyer or to any third part for any indirect, incidental, special, consequential, punitive or exemplary damages (including without limitation lost profits, lost savings, or loss of business opportunity) relating to any product, service provided or to be provided by Riverdi, or the use or inability to use the same, even if Riverdi has been advised of the possibility of such damages.

Riverdi products are not fault tolerant nor designed, manufactured or intended for use or resale as on line control equipment in hazardous environments requiring fail – safe performance, such as in the operation of nuclear facilities, aircraft navigation or communication systems, air traffic control, direct life support machines or weapons systems in which the failure of the product could lead directly to death, personal injury or severe physical or environmental damage ('High Risk Activities'). Riverdi and its suppliers specifically disclaim any expressed or implied warranty of fitness for High Risk Activities. Using Riverdi products and devices in 'High Risk Activities' and in any other application is entirely at the buyer's risk, and the buyer agrees to defend, indemnify and hold harmless Riverdi from any and all damages, claims or expenses resulting from such use. No licenses are conveyed, implicitly or otherwise, under any Riverdi intellectual property rights.

