

## SDS Series

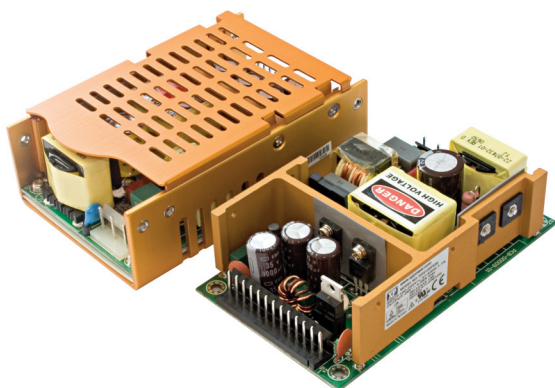

- Convection-cooled
- 3"x 5" Footprint
- Up to 90% Efficiency
- Open Frame, U-Channel & Covered Versions
- Low Temperature Option
- Single & Multi Outputs
- 3 Year Warranty

## Specification

## Input

Input Voltage	• 90-264 VAC (120-370 VDC)
Input Frequency	• 47-63 Hz
Input Current	• 120 W: 1.7 / 1.0 A max at 115 / 230 VAC 150 W: 2.0 / 0.8 A max at 115 / 230 VAC 180 W: 2.7 A max at 90 VAC
Inrush Current	• 120 W: 20 / 51 A max at 115 / 230 VAC 150 W: 54 / 63 A max at 115 / 230 VAC 180 W: 54 / 108 A max at 115 / 230 VAC
Power Factor	• >0.9
Earth Leakage Current	• 120 W: 0.30 / 0.75 mA at 115 / 230 VAC 150 W: 0.40 / 0.75 mA at 115 / 230 VAC 180 W: 0.75 mA at 230 VAC
Input Protection	• Internal T3.15 A / 250 VAC fuse in line
No Load Input Power	• 180 W: <0.5 W

## Output

Output Voltage	• See table
Output Voltage Trim	• $\pm 5\%$ output 1 only (3.3 V variant $\pm 10\%$ ) SDS180: not user adjustable
Initial Set Accuracy	• Single output models: $\pm 1\%$ Multi-output models: $\pm 5\%$
Minimum Load	• No minimum load required for single output models. For multi-output models (see table)
Start Up Delay	• 2 s max
Start Up Rise Time	• 2 ms typical
Hold Up Time	• 16 ms minimum at full load and 110 VAC
Line Regulation	• 0.5% typical
Load Regulation	• 3.0% typical
Transient Response	• 4% max deviation, recovery to within 1% in 500 $\mu$ s for a 50% load change
Ripple & Noise	• 1% pk-pk typical, 20 MHz bandwidth
Overvoltage Protection	• 112-132% V1 only, recycle input to reset
Overload Protection	• All outputs: 110-150% with auto recovery (primary power limit)
Short Circuit Protection	• Trip & restart (hiccup mode), auto recovery
Temperature Coefficient	• $\pm 0.04\%/^{\circ}\text{C}$

## General

Efficiency	• 120 W: 80% typical 150 W and 180 W: 88% typical
Isolation	• 3000 VAC Input to Output, 1500 VAC Input to Ground, 500 VDC Output to Ground
Isolation Resistance	• 50 M $\Omega$
Switching Frequency	• 120 W: PFC 100 kHz typical, PWM 67 kHz typical. 150 W: PFC 34 kHz minimum, PWM 55 kHz typical. 180 W: PFC 67 kHz typical, PWM 67 kHz typical
Power Density	• 120 W: 4.87 W/In <sup>3</sup> , 150 W: 6.50 W/In <sup>3</sup> 180 W: 7.47 W/In <sup>3</sup>
Signals	• Power Fail Detect = TTL active low, combined AC and DC OK signal (-P versions SDS120 & 150 only) Warning time 16 ms
MTBF	• >130 kHrs to MIL-HDBK-217F at 25 $^{\circ}\text{C}$ , GB

## Environmental

Operating Temperature	• 0 $^{\circ}\text{C}$ to +70 $^{\circ}\text{C}$ (-20 $^{\circ}\text{C}$ to +70 $^{\circ}\text{C}$ , SDS180), derate linearly from 100% load at +50 $^{\circ}\text{C}$ to 50% load at +70 $^{\circ}\text{C}$ , for low temperature option add suffix -L: -40 $^{\circ}\text{C}$ to +70 $^{\circ}\text{C}$ , SDS120 and SDS150, not available for SDS180
Cooling	• Convection-cooled
Operating Humidity	• 5-95% RH, non-condensing
Storage Temperature	• -40 $^{\circ}\text{C}$ to +85 $^{\circ}\text{C}$

## EMC &amp; Safety

Emissions	• EN55022, level B conducted & radiated.
Harmonic Currents	• EN61000-3-2 class A
Voltage Flicker	• EN61000-3-3
ESD Immunity	• EN61000-4-2, level 2 contact, Perf Criteria A SDS150: level 3 air, Perf criteria A
Radiated Immunity	• EN61000-4-3, level 2, Perf Criteria A
EFT/Burst	• EN61000-4-4, level 2, Perf Criteria A
Surge	• EN61000-4-5, installation class 3, Perf Criteria A
Conducted Immunity	• EN61000-4-6, level 2, Perf Criteria A
Magnetic Field	• EN61000-4-8, 1 A/m, Perf Criteria A
Dips & Interruptions	• EN61000-4-11, 30% 10 ms, 60% 100 ms, >95% 5000 ms Perf Criteria A, B, B
Safety Approvals	• EN60950-1, UL60950-1, CSA60950-1 per cUL, CE & UKCA meets all applicable directives & legislation

**Models and Ratings**

Output Power	Output 1				Output 2				Output 3				Model Number <sup>(2, 4, 5)</sup>
	Vnom	Imin	Imax	Tol. <sup>(1)</sup>	Vnom	Imin	Imax	Tol. <sup>(1)</sup>	Vnom	Imin	Imax	Tol. <sup>(1)</sup>	
72.0 W	3.3 V	0.00 A	22.00 A	5%									SDS120PS03B
110.0 W	5.0 V	0.00 A	22.00 A	5%									SDS120PS05B
115.0 W	7.0 V	0.00 A	16.42 A	5%									SDS120PS07B
120.0 W	9.0 V	0.00 A	13.33 A	4%									SDS120PS09B
120.0 W	12.0 V	0.00 A	10.00 A	3%									SDS120PS12B
120.0 W	15.0 V	0.00 A	8.00 A	3%									SDS120PS15B
120.0 W	18.0 V	0.00 A	6.66 A	3%									SDS120PS18B
120.0 W	24.0 V	0.00 A	5.00 A	2%									SDS120PS24B
120.0 W	28.0 V	0.00 A	4.28 A	2%									SDS120PS28B
120.0 W	36.0 V	0.00 A	3.33 A	2%									SDS120PS36B
120.0 W	48.0 V	0.00 A	2.50 A	2%									SDS120PS48B
79.5 W	+3.3 V	1.50 A	15.00 A	5%	+5.0 V	0.40 A	6.0 A	5%					SDS120PD00B
120.0 W	+3.3 V	1.50 A	15.00 A	5%	+12.0 V	0.20 A	6.0 A	5%					SDS120PD01B
120.0 W	+5.0 V	1.50 A	15.00 A	5%	+12.0 V	0.20 A	6.0 A	5%					SDS120PD02B
120.0 W	+5.0 V	1.50 A	15.00 A	5%	+15.0 V	0.20 A	6.0 A	5%					SDS120PD03B
120.0 W	+5.0 V	1.50 A	15.00 A	5%	+24.0 V	0.10 A	3.5 A	5%					SDS120PD04B
120.0 W	+5.0 V	1.50 A	15.00 A	5%	-24.0 V	0.20 A	2.0 A	5%					SDS120PD05B
120.0 W	+28.0 V	0.39 A	3.92 A	5%	+5.0 V	0.20 A	2.0 A	5%					SDS120PD06B
91.5 W	+3.3 V	1.50 A	15.00 A	5%	+5.0 V	0.60 A	6.0 A	5%	+12.0 V	0.00 A	1.0 A	5%	SDS120PT00B
91.5 W	+3.3 V	1.50 A	15.00 A	5%	+5.0 V	0.60 A	6.0 A	5%	-12.0 V	0.00 A	1.0 A	5%	SDS120PT01B
120.0 W	+3.3 V	1.50 A	15.00 A	5%	+12.0 V	0.60 A	6.0 A	5%	+5.0 V	0.00 A	0.8 A	5%	SDS120PT02B
120.0 W	+3.3 V	1.50 A	15.00 A	5%	+12.0 V	0.60 A	6.0 A	5%	-5.0 V	0.00 A	0.8 A	5%	SDS120PT03B
120.0 W	+3.3 V	1.50 A	15.00 A	5%	+12.0 V	0.60 A	6.0 A	5%	-12.0 V	0.00 A	0.8 A	5%	SDS120PT04B
120.0 W	+3.3 V	1.50 A	15.00 A	5%	+12.0 V	0.60 A	6.0 A	5%	+12.0 V	0.00 A	0.8 A	5%	SDS120PT05B
120.0 W	+5.0 V	1.50 A	15.00 A	5%	+12.0 V	0.60 A	6.0 A	5%	+5.0 V	0.00 A	0.8 A	5%	SDS120PT06B
120.0 W	+5.0 V	1.50 A	15.00 A	5%	+12.0 V	0.60 A	6.0 A	5%	-5.0 V	0.00 A	0.8 A	5%	SDS120PT07B
120.0 W	+5.0 V	1.50 A	15.00 A	5%	+12.0 V	0.60 A	6.0 A	5%	-12.0 V	0.00 A	0.8 A	5%	SDS120PT08B
120.0 W	+5.0 V	1.50 A	15.00 A	5%	+12.0 V	0.60 A	6.0 A	5%	+12.0 V	0.00 A	0.8 A	5%	SDS120PT09B
120.0 W	+5.0 V	1.50 A	15.00 A	5%	+15.0 V	0.60 A	6.0 A	5%	-15.0 V	0.00 A	0.8 A	5%	SDS120PT10B
120.0 W	+5.0 V	1.50 A	15.00 A	5%	+15.0 V	0.60 A	6.0 A	5%	+15.0 V	0.00 A	0.8 A	5%	SDS120PT11B
120.0 W	+5.0 V	1.50 A	15.00 A	5%	+24.0 V	0.35 A	3.5 A	5%	-24.0 V	0.00 A	0.8 A	5%	SDS120PT12B
120.0 W	+5.0 V	1.50 A	15.00 A	5%	+24.0 V	0.35 A	3.5 A	5%	+24.0 V	0.00 A	0.8 A	5%	SDS120PT13B
120.0 W	+5.0 V	1.50 A	15.00 A	5%	+24.0 V	0.35 A	3.5 A	5%	-12.0 V	0.00 A	0.8 A	5%	SDS120PT14B
120.0 W	+5.0 V	1.50 A	15.00 A	5%	+24.0 V	0.35 A	3.5 A	5%	+12.0 V	0.00 A	0.8 A	5%	SDS120PT15B
120.0 W	+5.0 V	1.50 A	15.00 A	5%	+10.0 V	0.60 A	6.0 A	5%	-10.0 V	0.00 A	1.0 A	5%	SDS120PT16B
120.0 W	+5.0 V	1.50 A	15.00 A	5%	+10.0 V	0.60 A	6.0 A	5%	+10.0 V	0.00 A	1.0 A	5%	SDS120PT17B

**Notes**

1. Tol. (total regulation) includes line regulation and load regulation.
2. For optional PCB only version, delete suffix 'B' from model number. Example SDS120PS03.
3. For non-standard voltages contact sales.
4. For optional low temperature -40 °C operation, add suffix '-L' to model number. Example: SDS120PS12B-L
5. For optional Power Fail Detect circuit, add suffix '-P' to model number, example: SDS120PS12B-P

**Mechanical Details**

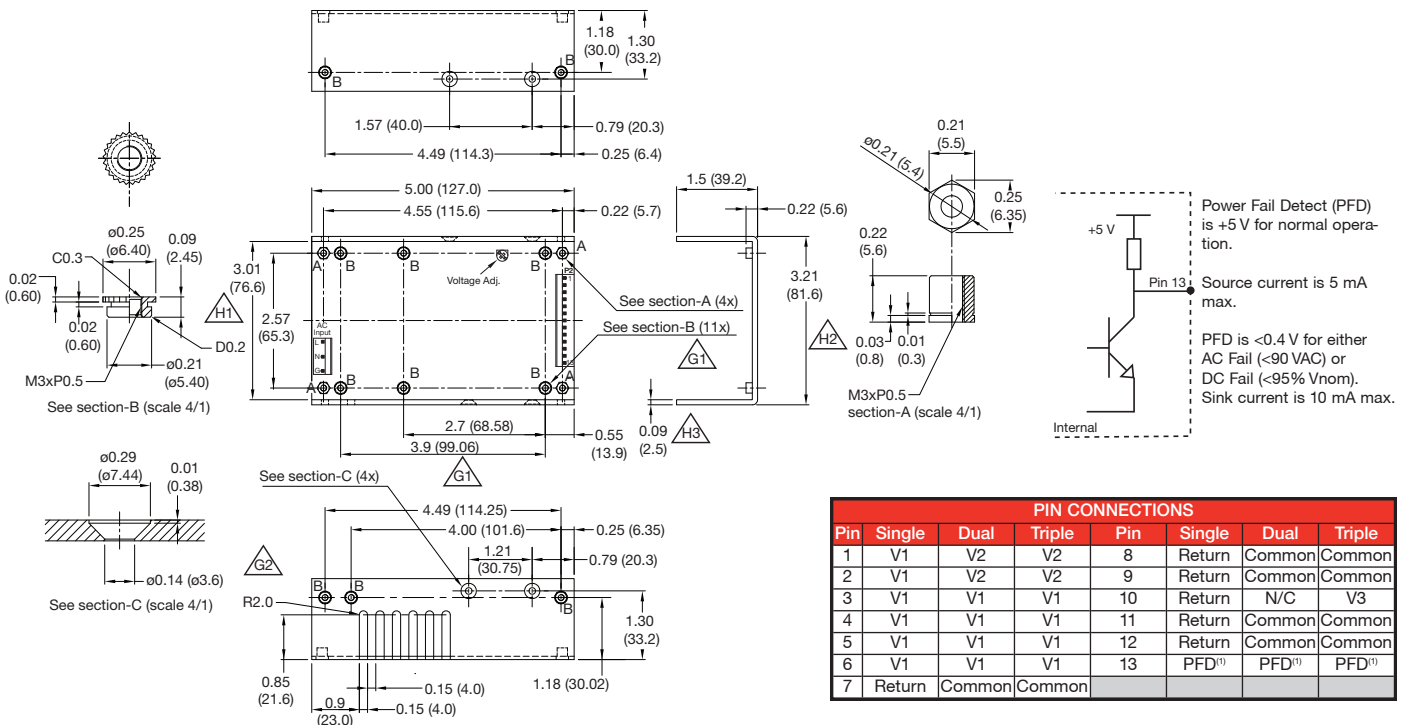

**Notes**

1. Optional Power Fail Detect signal on '-P' versions only. Standard models pin 13 is N/C.
2. I/P connector P1 mates with Molex housing 09-50-3051 & Molex 2878 series crimp terminal.
3. O/P P2 mates with Molex housing 09-50-3131 & Molex 2878 series crimp terminal.
4. For optional cover kit order part number SDS120 COVER, to receive unit with cover fitted add suffix '-C' to model number, e.g. SDS120PS12B-C (overall height is 1.73 (44.0)).
5. For mating connector kit order part number SDS120/SDS150 CON KIT.
6. For cable harness order part number SDS120S LOOM for single output models & SDS120M LOOM for multi-output models.
7. Maximum mounting screw penetration: 0.14 (3.5)
8. All dimensions are in inches (mm).
9. Weight: 0.77-0.99 lbs (350-450 g) approx.
10. For PCB-only version, overall dimensions are max 5.00 x 3.00 x 1.44 (127.0 x 76.2 x 36.6).

Output Power	Output Voltage	Output Current		Total Regulation <sup>(1)</sup>	Model Number <sup>(2,4,5,6)</sup>
		Minimum	Maximum		
144 W	9 V	0 A	16.00 A	5%	SDS150PS09B
150 W	12 V	0 A	12.50 A	5%	SDS150PS12B
150 W	15 V	0 A	10.00 A	5%	SDS150PS15B
150 W	18 V	0 A	8.33 A	4%	SDS150PS18B
150 W	24 V	0 A	6.25 A	3%	SDS150PS24B
150 W	30 V	0 A	5.00 A	2%	SDS150PS30B
150 W	36 V	0 A	4.17 A	2%	SDS150PS36B
150 W	48 V	0 A	3.13 A	2%	SDS150PS48B

Notes

1. Total regulation includes line regulation and load regulation.
2. For optional 2 pin Molex input, add suffix '-D' to model number. Example SDS150PS12B-D.
3. For non-standard voltages contact sales.
4. For optional low temperature -40 °C operation, add suffix '-L' to model number. Example: SDS150PS12B-L
5. For optional PCB only version, delete suffix 'B' from model number. Example SDS150PS48.
6. For optional Power Fail Detect signal (PFD), add suffix '-P' to model number. Example: SDS150PS48B-P.

Mechanical Details

U Channel

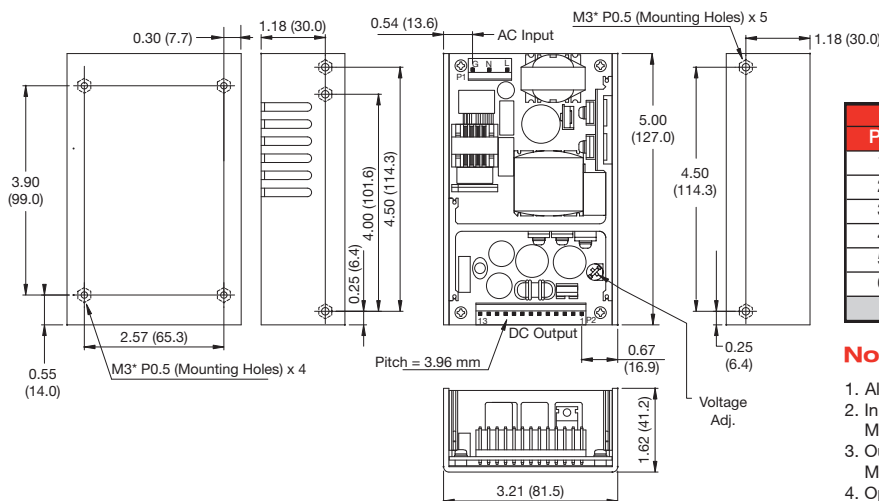

P2 - PIN CONNECTIONS			
Pin	Function	Pin	Function
1	V1	7	Return
2	V1	8	Return
3	V1	9	Return
4	V1	10	Return
5	V1	11	Return
6	V1	12	Return
		13	PFD <sup>(4)</sup>

Notes

1. All dimensions in inches (mm), tolerance ±0.02 (±0.5).
2. Input connector P1 mates with Molex housing 09-50-3051 and Molex 2478 series crimp terminal.
3. Output connector P2 mates with Molex housing 09-50-3131 and Molex 2478 series crimp terminal.
4. Optional power fail detect signal on '-P' versions only. Standard models pin 13 is not connected.
5. For mating connector kit order part number SDS120/SDS150 CON KIT.
6. For cable harness order part number SDS150 LOOM.
7. Maximum mounting screw penetration: 0.14 (3.5)
8. For optional cover kit order part number SDS150 COVER
9. Weight: U Channel - 1.27 lbs (580 g) approx.  
Open Frame - 0.86 lbs (390 g) approx.

Open Frame

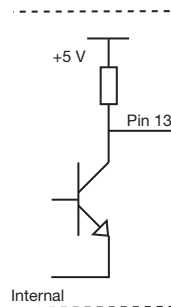
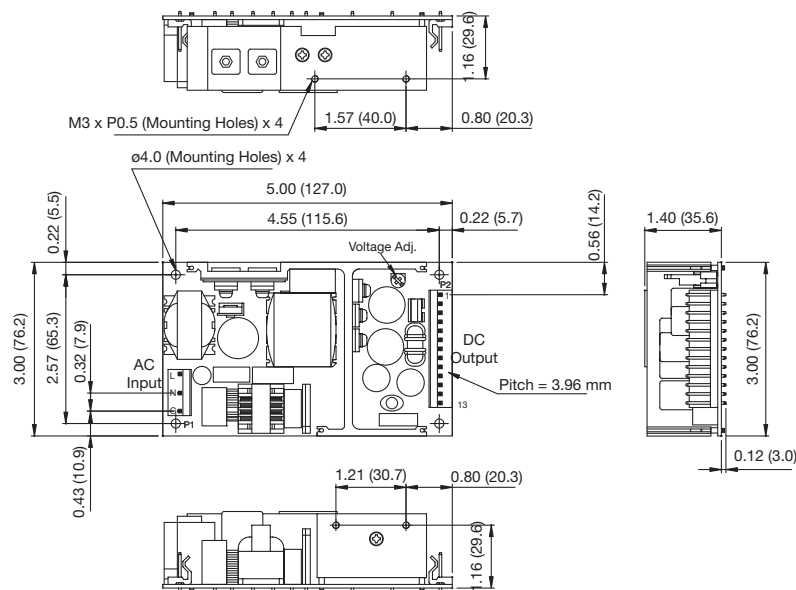

Power Fail Detect (PFD) is +5V for normal operation.

Source current is 5 mA max.

PFD is <0.4V for either AC Fail (<90 VAC) or DC Fail (<95% Vnom).

Sink current is 10 mA max.

**Models and Ratings**

Output Power	Output Voltage	Output Current		Total Regulation <sup>(2)</sup>	Model Number <sup>(3)</sup>
		Minimum	Maximum		
170 W <sup>(1)</sup>	12 V	0 A	14.16 A	5%	SDS180PS12B
180 W	24 V	0 A	7.50 A	3%	SDS180PS24B
180 W	48 V	0 A	3.75 A	2%	SDS180PS48B

**Notes**

1. Output power is 170 W at highline input and 160 W at low line input, (90-132 VAC).
2. Total regulation includes line regulation and load regulation.
3. For optional L-bracket version, delete suffix 'B' from model number. Example SDS180PS48.
4. For non-standard voltages contact sales.

**Mechanical Details**

**U Channel**

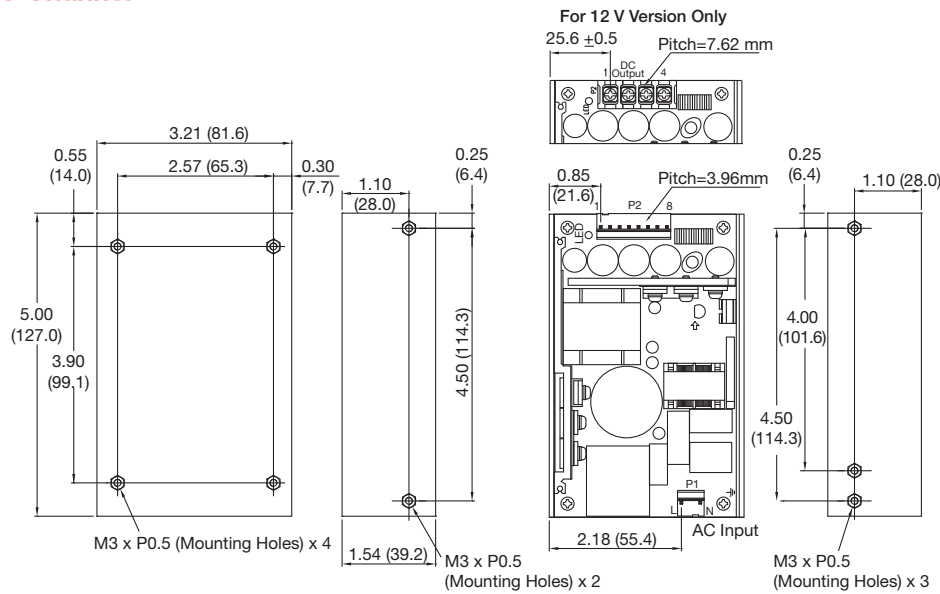

P2 - PIN CONNECTIONS 24/48 V versions			
Pin	Function	Pin	Function
1	Return	5	V1
2	Return	6	V1
3	Return	7	V1
4	Return	8	V1

PIN CONNECTIONS 12 V version			
Pin	Function	Pin	Function
1	Return	3	V1
2	Return	4	V1

**L-bracket**

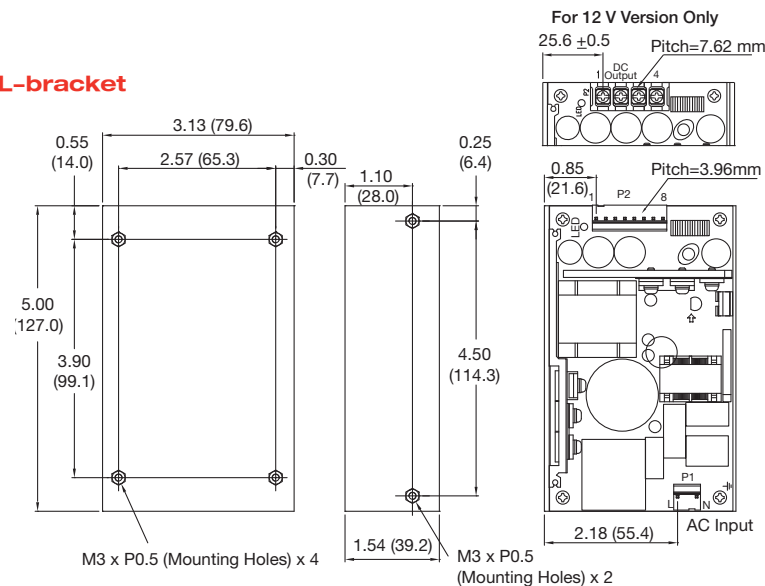

**Notes**

1. All dimensions in inches (mm), tolerance  $\pm 0.02$  ( $\pm 0.5$ ).
2. Input connector P1 mates with Molex housing 09-50-3031 and Molex 2478 series crimp terminal.
3. Output connector P2 mates with Molex housing 09-50-3061 (or 09-50-3081) and Molex 2478 series crimp terminal for 24/48 V Versions. For 12 V Version, output terminal is screw terminal.
4. For mating connector kit order part number: SDS180 CON KIT.
5. For cable harness order part number SDS180 LOOM.
6. Maximum mounting screw penetration: 0.14 (3.5)
7. Weight: U Channel - 1.14 lbs (520 g)  
L-bracket - 1.06 lbs (480 g)