

APPROVAL SHEET

MULTILAYER CERAMIC ANTENNA

**2.4 GHz/ 5GHz Full Band Working Frequency
– RoHS Compliance**

Halogens Free Product

For 802.11a/ b/ g Combo Application

Part Number:

RFANT6050110L0T

RFANT6050110L1T

*Contents in this sheet are subject to change without prior notice.

FEATURES

1. Combo application for IEEE 802.11b/g/a, broadband high frequency design cover with 2.4GHz , 5.2GHz, and 5.8GHz
2. SMD antenna requires least space and lowest assembly cost.
3. Embedded Antenna with a smallest dimension of **5.9 x 5.1 x 1.1 mm³** meets to miniaturization trend.
4. Broad bandwidth design with the less sensitive characteristics to the GND pad and external environment deviation.
5. LTCC (Low Temperature Co-fired Ceramic) Multi-Layer technology to beautify the housing / outlook of the final product.

APPLICATIONS

1. Wireless LAN 802.11a/ b/ g combo application.

DESCRIPTION

Walsin Technology Corporation develops a new ceramic embedded antenna specified for 2.4 GHz/ 5GHz ISM Band application, as shown in below "CONSTRUCTION". Both of Wireless LAN IEEE 802.11b and Bluetooth™ typically located on this unlicensed frequency band which range covers from 2.4GHz to 2.4835GHz, to increase the data throughput rate, 802.11a is proposed and located on high band 5GHz. To fulfil the combo application requirements, the new embedded ceramic antenna was released by Walsin Technology Corporation.

This new antenna covers both 2.4GHz/ 5GHz which can fulfill the WLAN IEEE802.11b/g/a combo application. The antenna covers 5GHz high frequency band from 4.6GHz up to 6.0GHz with a peak Gain reaches 4dBi further meeting the 802.11a/ HiperLAN requirement, also Japan's new band 4.9GHz to 5.1GHz application. This combo embedded ceramic antenna been designed through Walsin's advanced LTCC (Low Temperature Co-fired Ceramic) technology and superior product design via 3D EM Simulation Skill.

This combo antenna has a rectangular ceramic body with a tiny dimension of 5.9x 5.1 x 1.1 mm³ meet the future SMT automation and miniaturization requirements on modern portable devices.

CONSTRUCTION

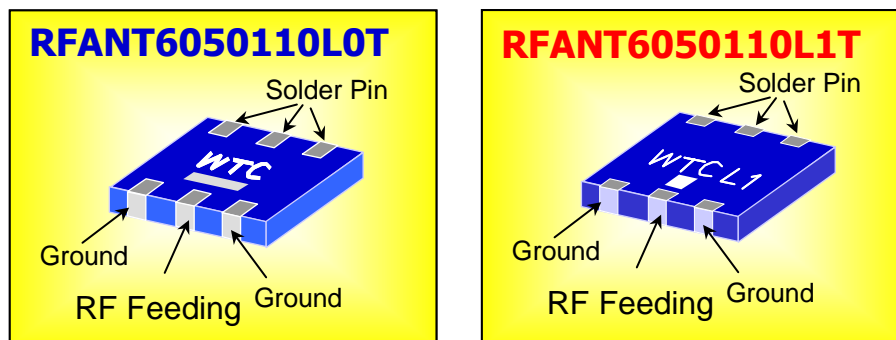

Fig 1. Outline of RFANT6050110L0T and RFANT6050110L1T Combo Antenna

ELECTRICAL CHARACTERISTICS for both RFANT6050110L0T/ RFANT6050110L1T

Item	Specification		
Central frequency	2.45GHz	5.25GHz	5.85GHz
Bandwidth (Typical)	100 MHz	200 MHz	100 MHz
Peak Gain (Typical)	4 dBi	4 dBi	4 dBi
VSWR	2 max.		
Polarization	Linear		
Impedance	50Ω		

Note-1. Central Frequency, Gain and Bandwidth should be defined after customers' application approval.

Remark: For RFANT6050110L0T, the mark is "WTC"
 For RFANT6050110L1T, the mark is "WTC L1"

SOLDER LAND PATTERN DESIGN

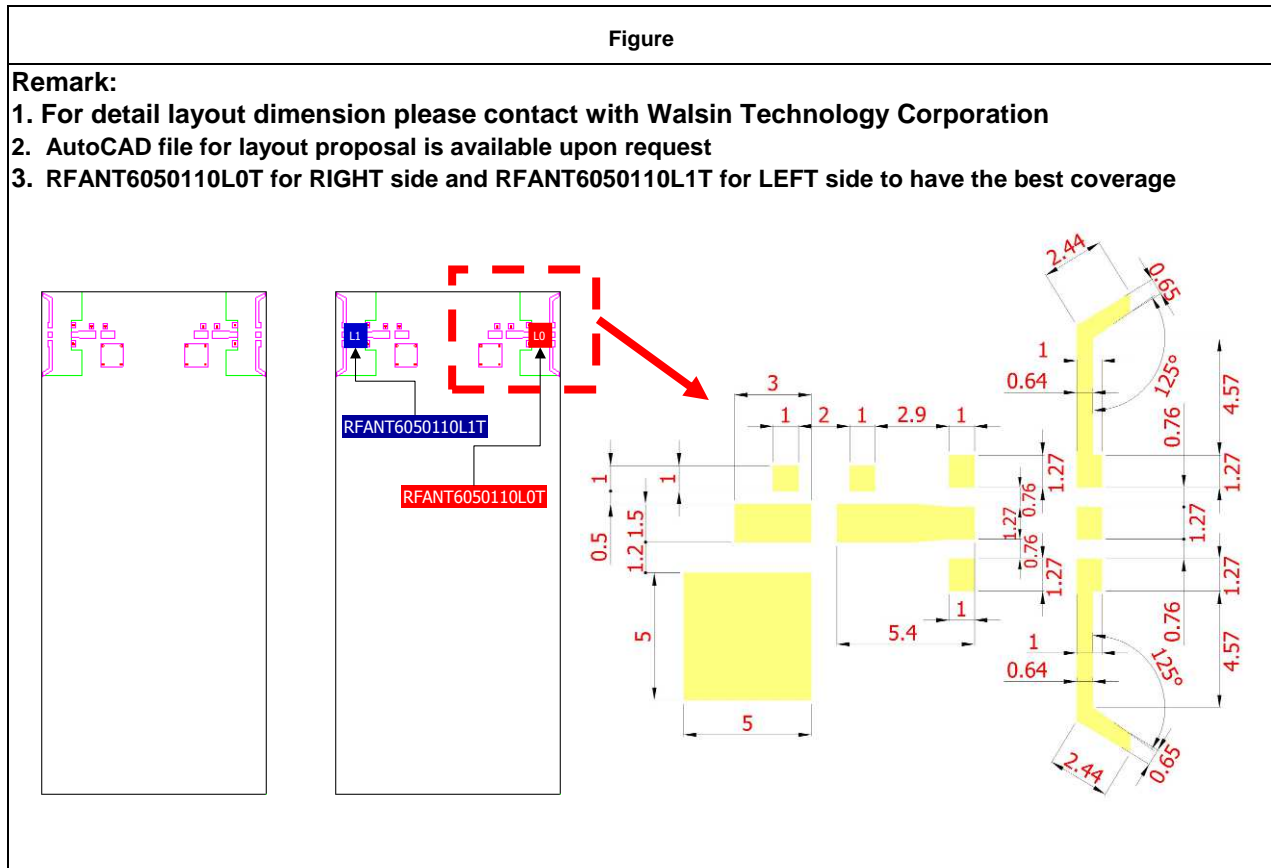

DIMENSION

RFANT6050110L0T			RFANT6050110L1T		
Symbol	Dimension	Port Definition	Symbol	Dimension	Port Definition
L	5.9 ± 0.3mm	---	c	1.0 ± 0.2mm	---
W	5.1 ± 0.3mm	---	d	2.0 ± 0.2mm	---
T	1.1 ± 0.1mm	---	1	1.0 ± 0.2mm	50 Ω RF Feeding
a	0.45 ± 0.2mm	---	2	1.0 ± 0.2mm	Ground Termination
b	1.0 ± 0.2mm	---	3	1.0 ± 0.2mm	Solder Termination

RADIATION PATTERN

Radiation Pattern and Gain were dependent on measurement board design. The specification of RFANT6050110L0T/ RFANT6050110L1T Combo antenna were measured based on the PCB size and installation position with housing was included.

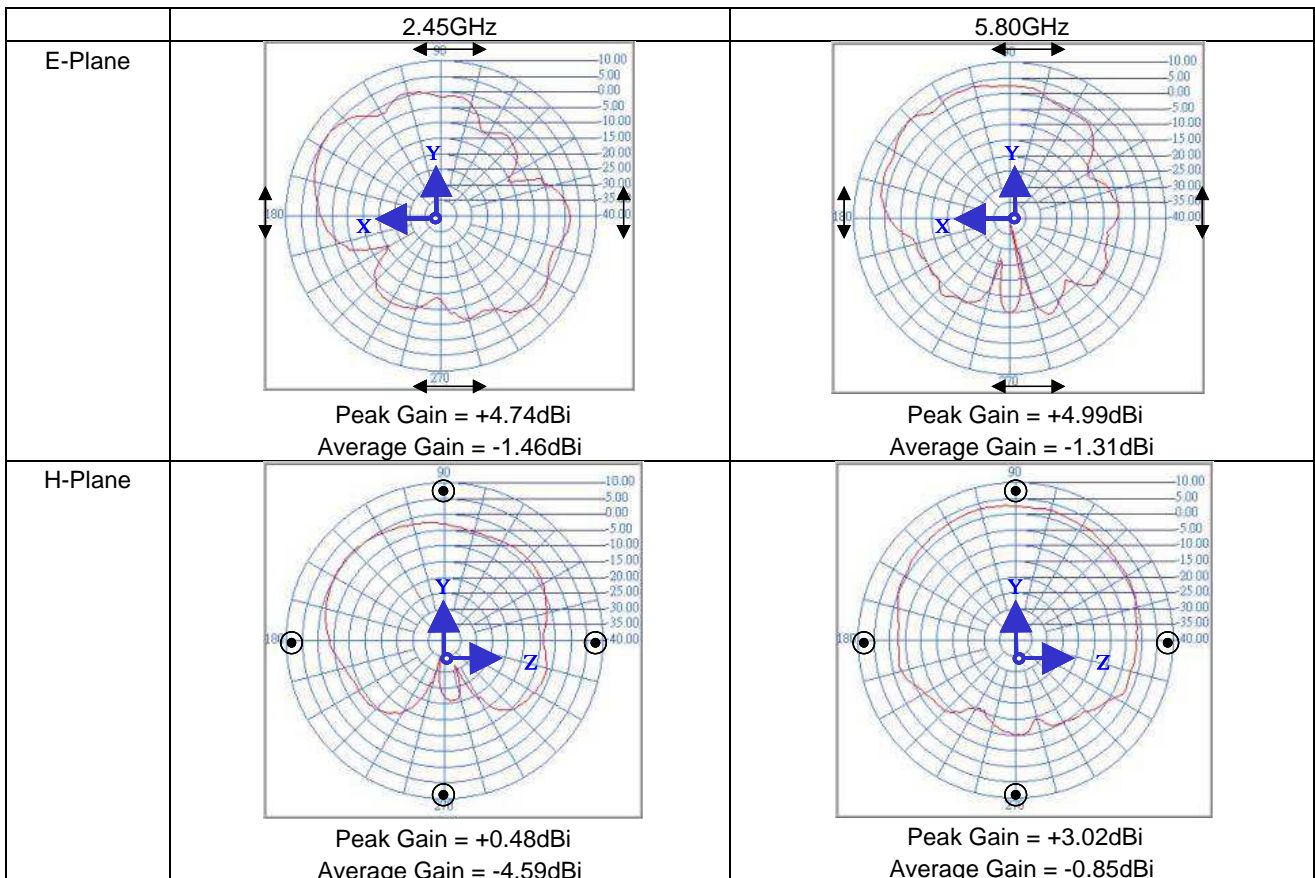
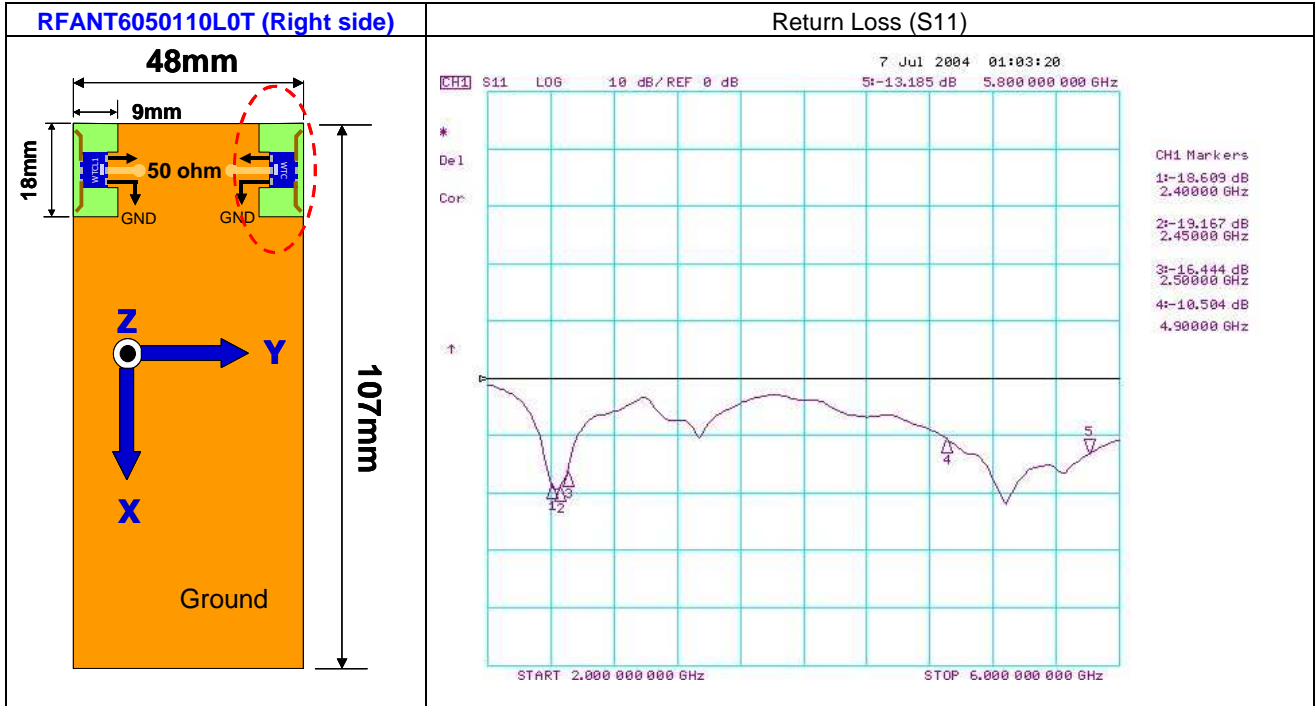

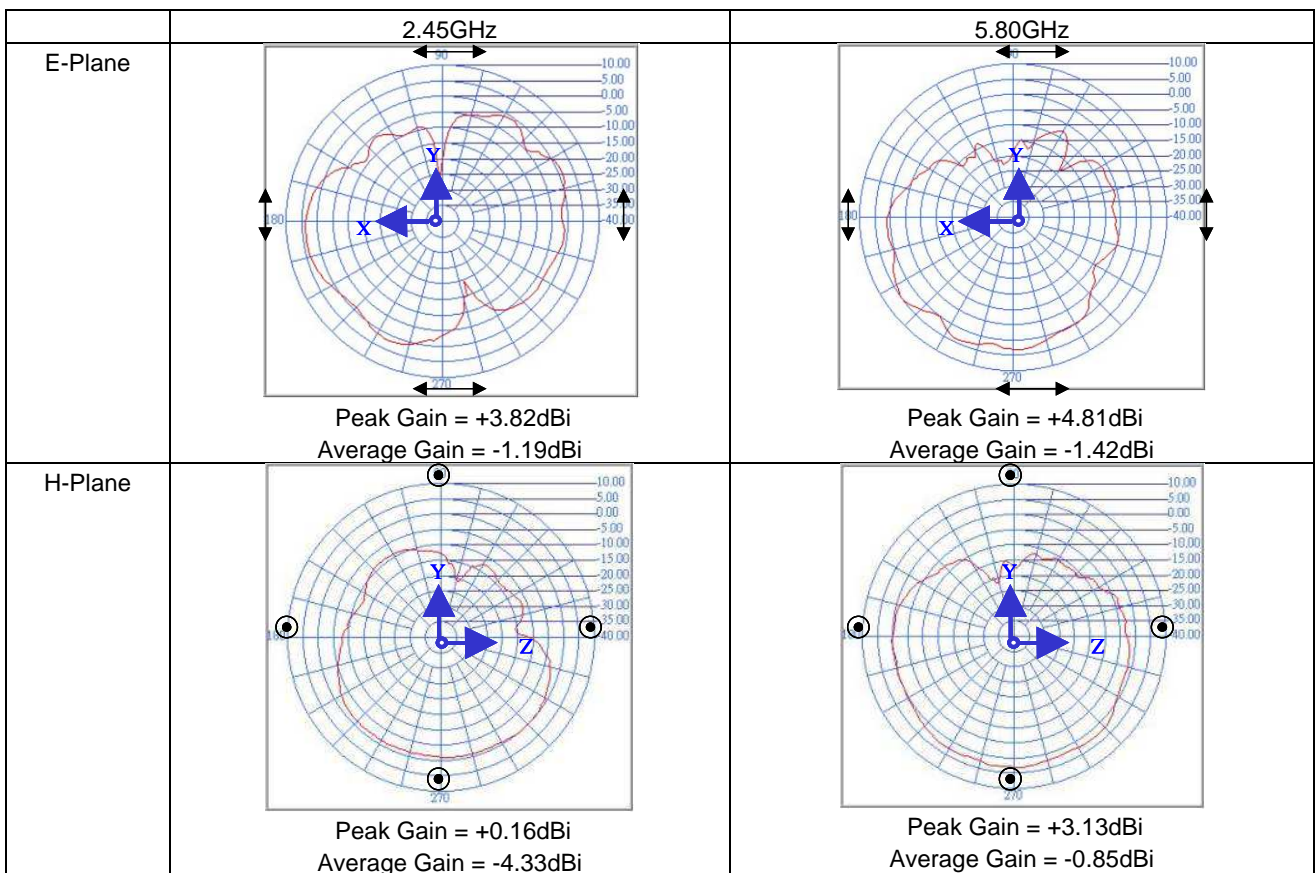
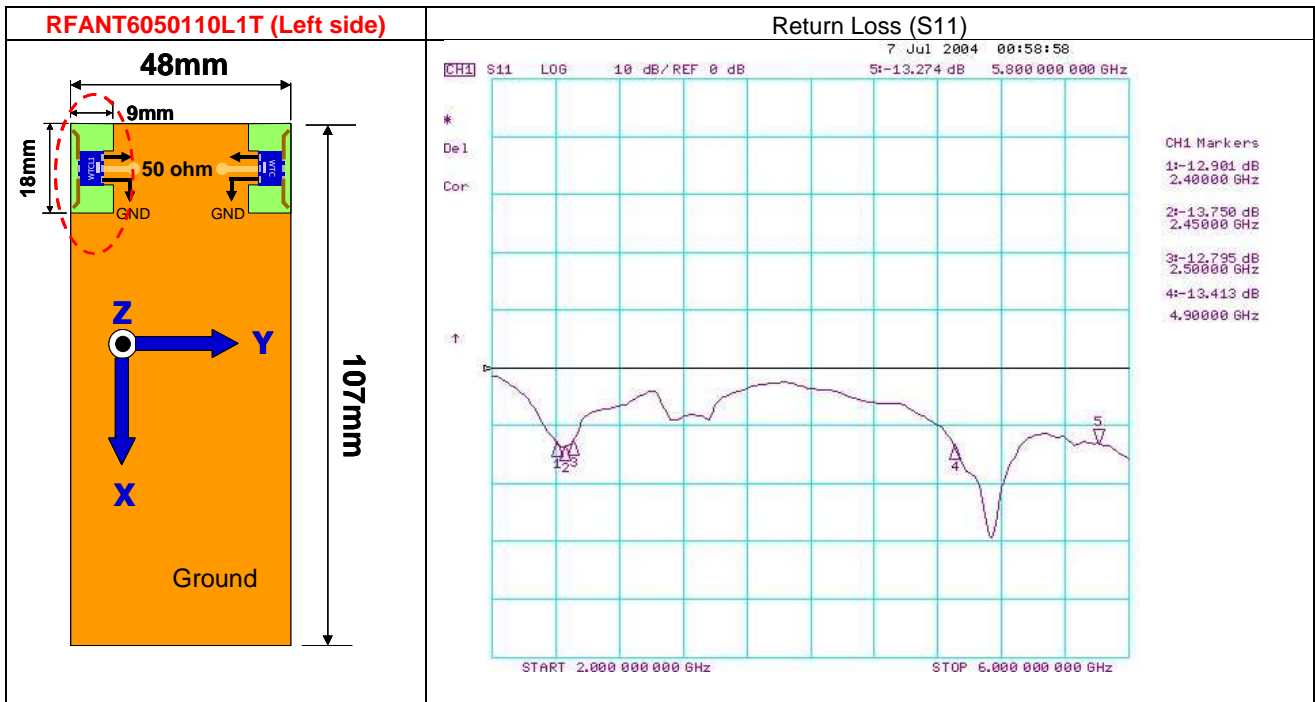

Remark:

- Unit : dBi
- Polarization directions: parallel to paper
 normal to paper

The installation for the two antennas could be arranged as RFANT6050110L0T located on RIGHT side and RFANT605010L1T located on LEFT side to have the best antenna coverage.

The performance of embedded ceramic antenna is sensitive influenced by customer's ground area, PC board size, thickness, material, mechanical design and the material of housing for end product. The performance is guaranteed based on the installation as shown in above, to reserve a "Π" network is suggested for final matching if the housing included.

Walsin engineers have significant expertise on embedded antenna designs and applications. We can work closely with you to ensure the requirements are met, and optimise the Walsin antenna performance when installing on your application.

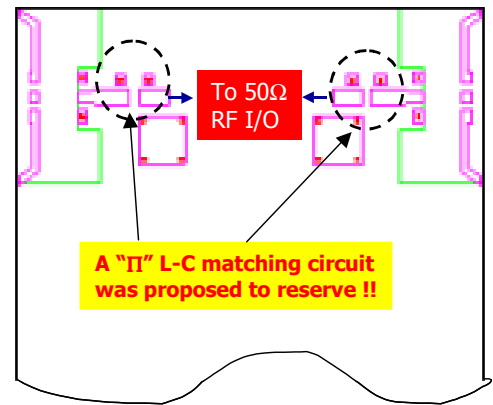

RELIABILITY TEST

Mechanical performance

Test item	Test condition / Test method	Specification
Solderability	Solder temp. : $235 \pm 5^\circ\text{C}$ Immersion time: 2 ± 1 sec Solder: SN63	95% min. coverage of all metabolised area
Resistance to soldering heat	Solder: Sn63 Preheating temperature: $150 \pm 10^\circ\text{C}$ Solder Temperature: $260 \pm 5^\circ\text{C}$ Immersion time: 10 ± 1 sec Measurement to be made after keeping at room temp. for 24 ± 2 hrs.	No mechanical damage. Ceramic surface shall not be exposed in the middle of the termination or on the terminated product edge by leaching.
Drop test	Height : 75 cm Times : 3 times.	No mechanical damage. Samples shall satisfy electrical specification after test..

Environmental characteristics

Test item	Test condition / Test method	Specification
Humidity Resistance	Humidity: 90% to 95% R.H. Temperature: $40 \pm 2^\circ\text{C}$ Time: 500 ± 24 hours. Measurement: After placing for 24 hours Minimum.	No mechanical damage. Samples shall satisfy electrical specification after test.
Temperature cycle	1. 30 ± 3 minutes at $-40^\circ\text{C} \pm 3^\circ\text{C}$, 2. 10~15 minutes at room temperature, 3. 30 ± 3 minutes at $+85^\circ\text{C} \pm 3^\circ\text{C}$, 4. 10~15 minutes at room temperature, Total 100 continuous cycles Measurement after placing for 48 ± 2 hrs min.	No mechanical damage. Samples shall satisfy electrical specification after test.
High temperature	Temperature: $85^\circ\text{C} \pm 2^\circ\text{C}$ Test duration: 24 hours	No mechanical damage. Samples shall satisfy electrical specification after test.

	Measurement must be taken after subsection to the above conditions, followed by exposure in room environment for 1 to 2 hours.	
Low temperature	Temperature: $-40^{\circ}\text{C}\pm 3^{\circ}\text{C}$ Test duration: 24 hours Measurement must be taken after subsection to the above conditions, followed by exposure in room environment for 1 to 2 hours.	No mechanical damage. Samples shall satisfy electrical specification after test.

PACKAGING

Plastic Tape specifications (unit :mm)

(1). RFANT6050110L0T

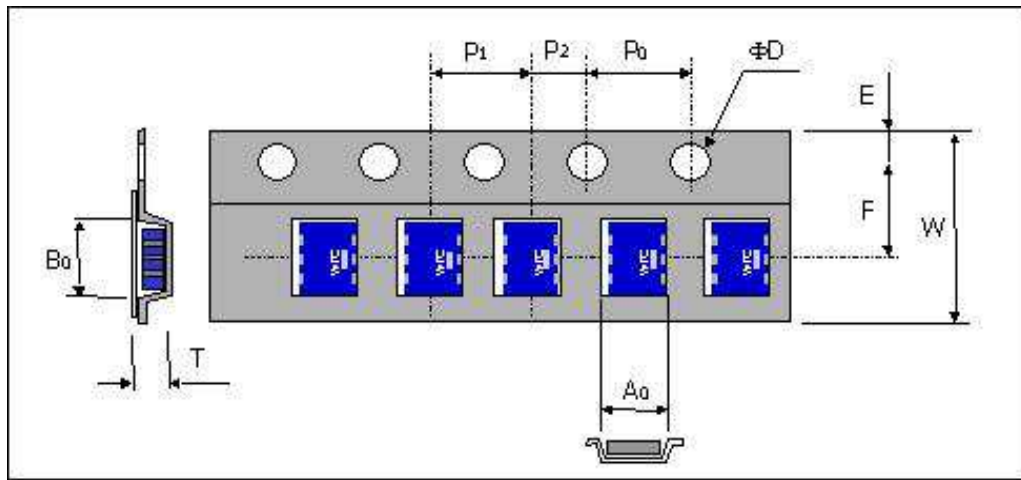

(2). RFANT6050110L1T

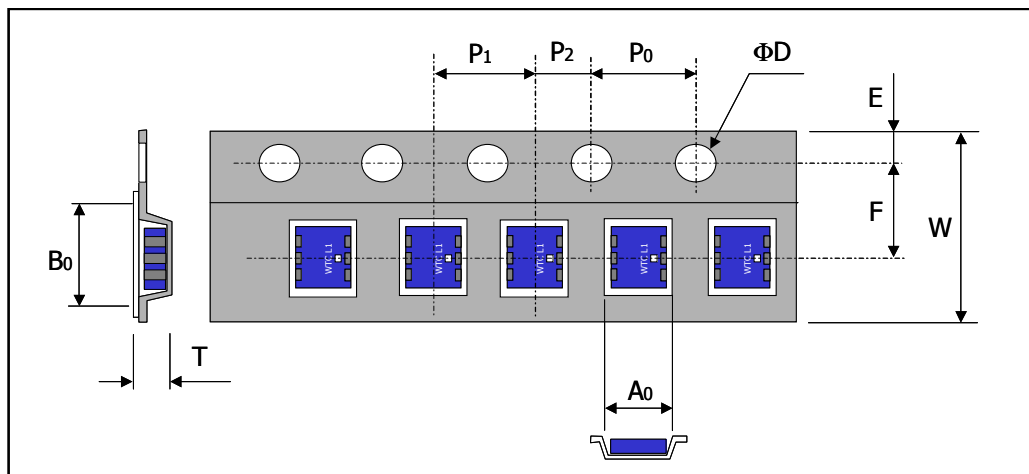

Index	Ao	Bo	ΦD	T	W
Dimension (mm)	5.50 ± 0.10	6.25 ± 0.10	1.55 ± 0.05	1.50 ± 0.10	12.0 ± 0.30
Index	E	F	Po	P1	P2
Dimension (mm)	1.75 ± 0.10	5.50 ± 0.05	4.00 ± 0.10	4.00 ± 0.10	2.00 ± 0.10

Reel dimensions

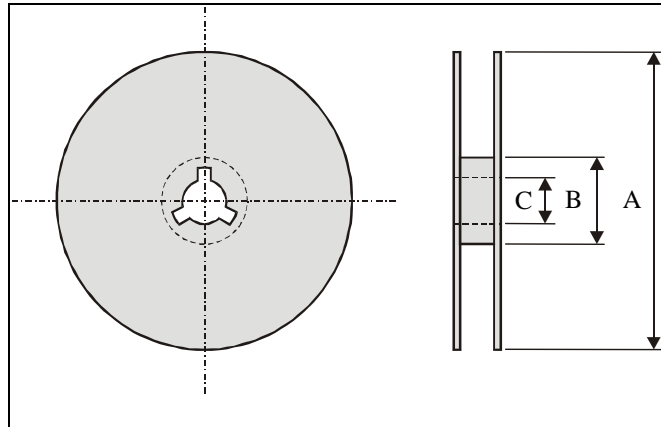

Index	A	B	C
Dimension (mm)	Φ178	Φ60.0	Φ13.5

Typing Quantity: 1000 pieces per 7" reel

ORDERING CODE

RF	ANT	605011	0	L	x	T
Walsin RF device	Product code ANT : Antenna	Dimension code Per 2 digits of Length, Width, Thickness : e.g. : 605011 = Length 60, Width 50, Thickness 11	Unit of dimension 0 : 0.1 mm 1 : 1.0 mm	Application L: 2.4GHz/ 5.2GHz/ 5.8GHz application	Specification Design Code	Packing T : 7" Reeled

CAUTION OF HANDLING

Limitation of Applications

Please contact us before using our products for the applications listed below which require especially high reliability for the prevention of defects, which might directly cause damage to the third party's life, body or property.

- (1) Aircraft equipment
- (2) Aerospace equipment
- (3) Undersea equipment
- (4) Medical equipment
- (5) Disaster prevention / crime prevention equipment
- (6) Traffic signal equipment
- (7) Transportation equipment (vehicles, trains, ships, etc.)
- (8) Applications of similar complexity and /or reliability requirements to the applications listed in the above.

Storage condition

- (1) Products should be used in 6 months from the day of WALSIN outgoing inspection, which can be confirmed.
- (2) Storage environment condition.
 - Products should be storage in the warehouse on the following conditions.
 - Temperature : -10 to +40°C
 - Humidity : 30 to 70% relative humidity
 - Don't keep products in corrosive gases such as sulfur. Chlorine gas or acid or it may cause oxidization of electrode, resulting in poor solderability.
 - Products should be storage on the palette for the prevention of the influence from humidity, dust and so on.
 - Products should be storage in the warehouse without heat shock, vibration, direct sunlight and so on.