



SPECIFICATIONS

CUSTOMER : _____

SAMPLE CODE : SH320240T023-IHC09

MASS PRODUCTION CODE : PH320240T023-IHC09

SAMPLE VERSION : 01

SPECIFICATIONS EDITION : 004

DRAWING NO. (Ver.) : LMD-PH320240T023-IHC09 (Ver.003)

PACKAGING NO. (Ver.) : PKG-PH320240T023-IHC09 (Ver.002)

Customer Approved

Date: _____

Approved	Checked	Designer
黃秋源 Oliver Huang	石建莊 Stone Shin	王聖硯 Stephen Wang

- Preliminary specification for design input
- Specification for sample approval



POWERTIP TECH. CORP.

Headquarters: No.8, 6th Road, Taichung Industrial Park, Taichung, Taiwan
 台中市 407 工業區六路 8 號

TEL: 886-4-2355-8168 E-mail: sales@powertip.com.tw
 FAX: 886-4-2355-8166 Http://www.powertip.com.tw

Contents

1. SPECIFICATIONS

- 1.1 Features
- 1.2 Mechanical Specifications
- 1.3 Absolute Maximum Ratings
- 1.4 DC Electrical Characteristics
- 1.5 Optical Characteristics
- 1.6 Backlight Characteristics
- 1.7 Touch Panel Characteristics

2. MODULE STRUCTURE

- 2.1 Counter Drawing
- 2.2 Interface Pin Description
- 2.3 Timing Characteristics
- 2.4 Power Sequence

3. QUALITY ASSURANCE SYSTEM

- 3.1 Quality Assurance Flow Chart
- 3.2 Inspection Specification

4. RELIABILITY TEST

- 4.1 Reliability Test Condition

5. PRECAUTION RELATING PRODUCT HANDLING

- 5.1 Safety
- 5.2 Handling
- 5.3 Storage
- 5.4 Terms of Warranty

Appendix : LCM Drawing
LCM Packaging Specifications

Note:

For detailed information please refer to IC data sheet
LCD Controller: HX8238-D

1. SPECIFICATIONS

1.1 Features

Item	Standard Value
Touch Panel	Projective Capacitive Touch Panel
Screen Size(inch)	3.5 (Diagonal)
Viewing Direction	6 O'clock
Resolution	320* (R · G · B) * 240 Dots
LCD Type	Transmissive, a-Si TFT
Weight	92.9 g
Interface	Raspberry Pi DPI /GPIO / 18 Bit RGB (DPI_OUTPUT_FORMAT_18BIT_666_CFG1)
Other Driver	HX8238-D
ROHS	THIS PRODUCT CONFORMS THE ROHS OF PTC Detail information please refer website : http://www.powertip.com.tw/news_detail.php?Key=1&clD=1

1.2 Mechanical Specifications

Item	Standard Value	Unit
Outline Dimension	84.02(W) * 75.36 (L) * 22.4 (H)	mm

LCD panel

Item	Standard Value	Unit
Active Area	70.08 (W) * 52.56 (L)	mm

Note : For detailed information please refer to LCM drawing.

1.3 Absolute Maximum Ratings

Item	Symbol	Condition	Min.	Max.	Unit
Power Supply Voltage	VCC	-	-0.3	+3.96	V
	VDD	-	-0.3	+20	V
Logic Voltage	BL_PWM	-	-0.3	+20	V
Operating Temperature	T _{OP} (Ts)	Note 1	-20	+70	°C
Storage Temperature	T _{ST} (Ta)	Note 2	-30	+80	°C
Storage Humidity	H _D	Ta < 60 °C	-	90	%RH

Note 1 : Ts is the temperature of panel's surface

Note 2 : Ta is the ambient temperature of samples

1.4 DC Electrical Characteristics

Item	Symbol	Status	Condition	Min.	Typ.	Max.	Unit
Power Supply Voltage	VCC	I	VCC-GND	3.0	3.3	3.6	V
	VDD	I	VDD-GND	4.5	5.0	5.5	V
Power Supply Current	ICC	I	VCC=3.3v	-	30	40	mA
	IDD	I	VDD=5.0v	-	90	110	mA
Input Logic High Voltage	VIH	-	-	0.8*VCC	-	VCC	V
Input Logic Low Voltage	VIL	-	-	GND	-	0.2*VCC	V
Logic Voltage	BL_PWM	-	-	-	3.3	-	V
PWM Frequency	FPWM	-	-	5	-	100	KHz

Note: Maximum current from RGB full-display

1.5 Optical Characteristics

TFT LCD Panel

Ta=25°C

Item	Symbol	Condition	Min.	Typ.	Max.	Unit	-	
Response Time	Tr + Tf	-	-	40	60	ms	Note2	
Viewing Angle	Top	ΘY+	CR ≥ 10	-	60	-	Deg.	Note4
	Bottom	ΘY-		-	60	-		
	Left	ΘX-		-	60	-		
	Right	ΘX+		-	60	-		
Contrast Ratio	CR	-	500	600	-	-	Note3	
Color of CIE Coordinate (With B/L)	White	X	-	0.27	0.32	0.37	-	Note1
		Y		0.30	0.35	0.40		
	Red	X		0.59	0.64	0.69		
		Y		0.29	0.34	0.39		
	Green	X		0.29	0.34	0.39		
		Y		0.56	0.61	0.66		
	Blue	X		0.09	0.14	0.19		
		Y		0.03	0.08	0.13		
Average Brightness Pattern=White Display	IV	IF=20 mA	680	850	-	cd/m ²	Note1	
Luminance Uniformity	YU	IF=20 mA	70	-	-	%	Note1	

Note1:

1 : $\Delta B = B(\min) / B(\max) \times 100\%$

2 : Measurement Condition for Optical Characteristics:

a : Environment: 25°C ± 5°C / 60 ± 20% R.H , no wind , dark room below 10 Lux at typical lamp current and typical operating frequency.

b : Measurement Distance: 500 ± 50 mm , (θ = 0°)

c : Equipment: TOPCON BM-7 fast , (field 1°) , after 10 minutes operation.

d : The uncertainty of the C.I.E coordinate measurement ± 0.01 , Average Brightness ± 4%

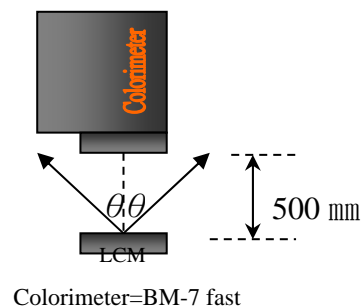
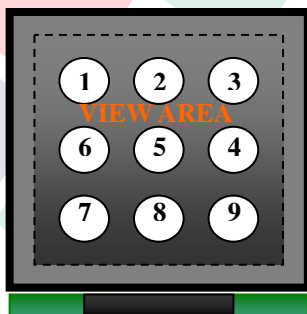

Note2: Definition of response time:

The output signals of photo detector are measured when the input signals are changed from “black” to “white”(falling time) and from “white” to “black”(rising time), respectively. The response time is defined as the time interval between the 10% and 90% of Amplitudes.

Refer to figure as below:

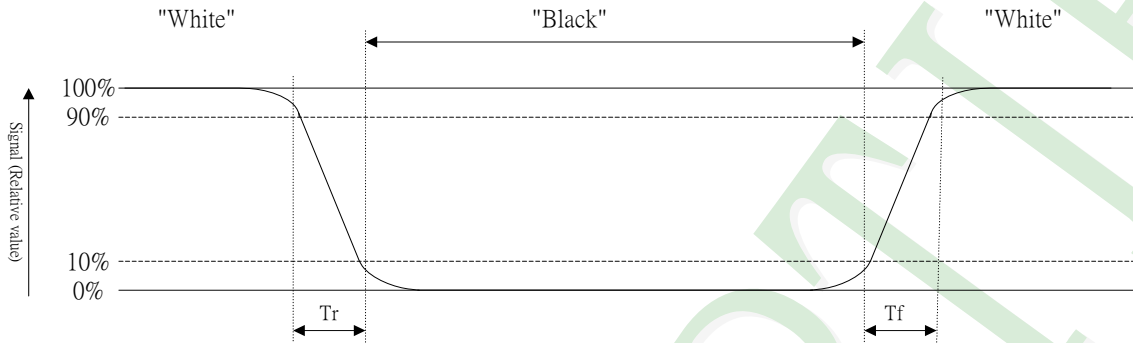

Note3: Definition of contrast ratio:

Contrast ratio is calculated with the following formula

$$\text{Contrast ratio (CR)} = \frac{\text{Photo detector output when LCD is at "White" state}}{\text{Photo detector output when LCD is at "Black" state}}$$

Note4: Definition of viewing angle:

Refer to figure as below:

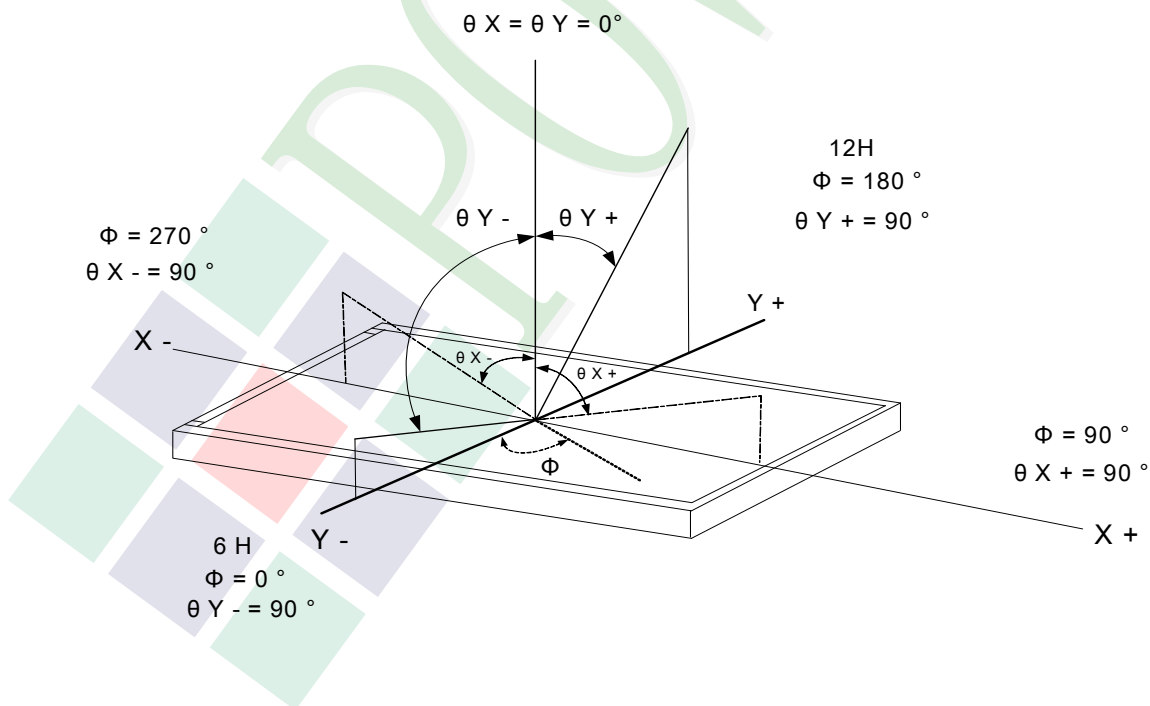

1.6 Backlight Characteristics

1.6.1 DC Characteristics

Maximum Ratings

Item	Symbol	Conditions	Min.	Typ.	Max.	Unit
Power Dissipation	Pd	-	-	396	-	mW
LED Forward Current	IF	1 LED	-	-	30	mA
LED Reverse Voltage	VR	1 LED	-	-	5	V

Electrical / Optical Characteristics

Item	Symbol	Conditions	Min.	Typ.	Max.	Unit
Voltage for LED Backlight	VF	If=20mA	18.0	19.0	19.8	V
Current for LED Backlight	IF		-	20	-	mA
Color	White					

Other Description

Item	Conditions	Description
Life Time	Ta =25°C If= 80 mA	50000 hrs

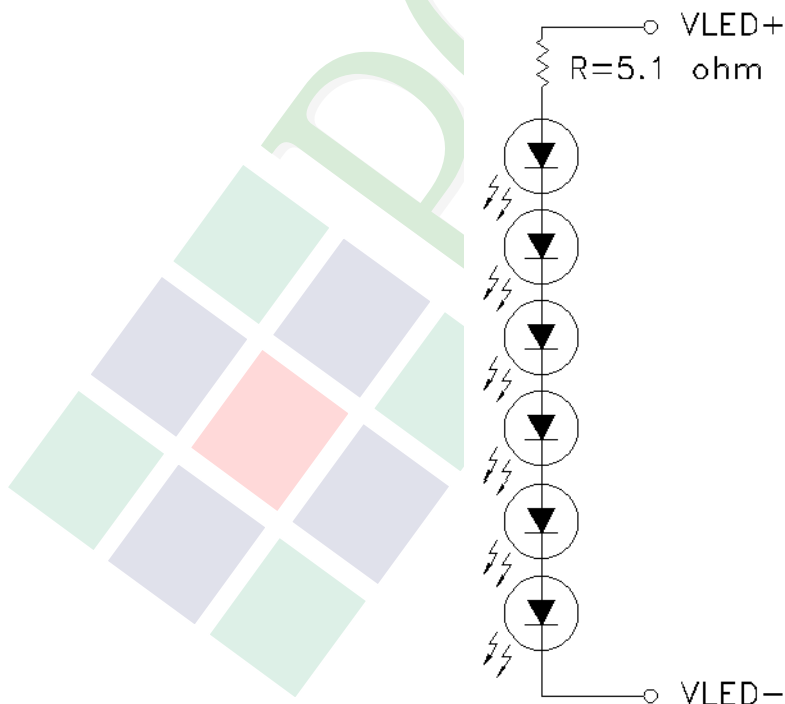

1.7 Touch Panel Characteristics

Features

Item	Standard Value
Touch Panel Size	3.5"
Touch Type	Projective Capacitive Touch Panel
Input Method	Finger / 5 Points Touch
Output Interface	I ² C
IC	ICNT8826

Mechanical Specifications

Item	Standard Value	Unit
Viewing Area	71.08 (W) * 53.56 (L)	mm

Absolute Maximum Ratings

Item	Symbol	Condition	Min.	Max.	Unit
Supply Voltage	TP_VDD	-	-0.3	+6.0	V
Operating Temperature	T _{OP}	-	-20	+70	°C
Storage Temperature	T _{ST}	-	-30	+80	°C

DC Electrical Characteristics

Item	Symbol	Condition	Min.	Typ.	Max.	Unit
Power Supply Voltage	TP_VDD	-	-	3.3	-	V

Touch Panel IC Read/Write Description & Register Mapping

Reference: Chipone Touch Driver Porting Reference Guide.

2. MODULE STRUCTURE

2.1 Counter Drawing

2.1.1 LCM Mechanical Diagram

* See Appendix

2.1.2 Block Diagram

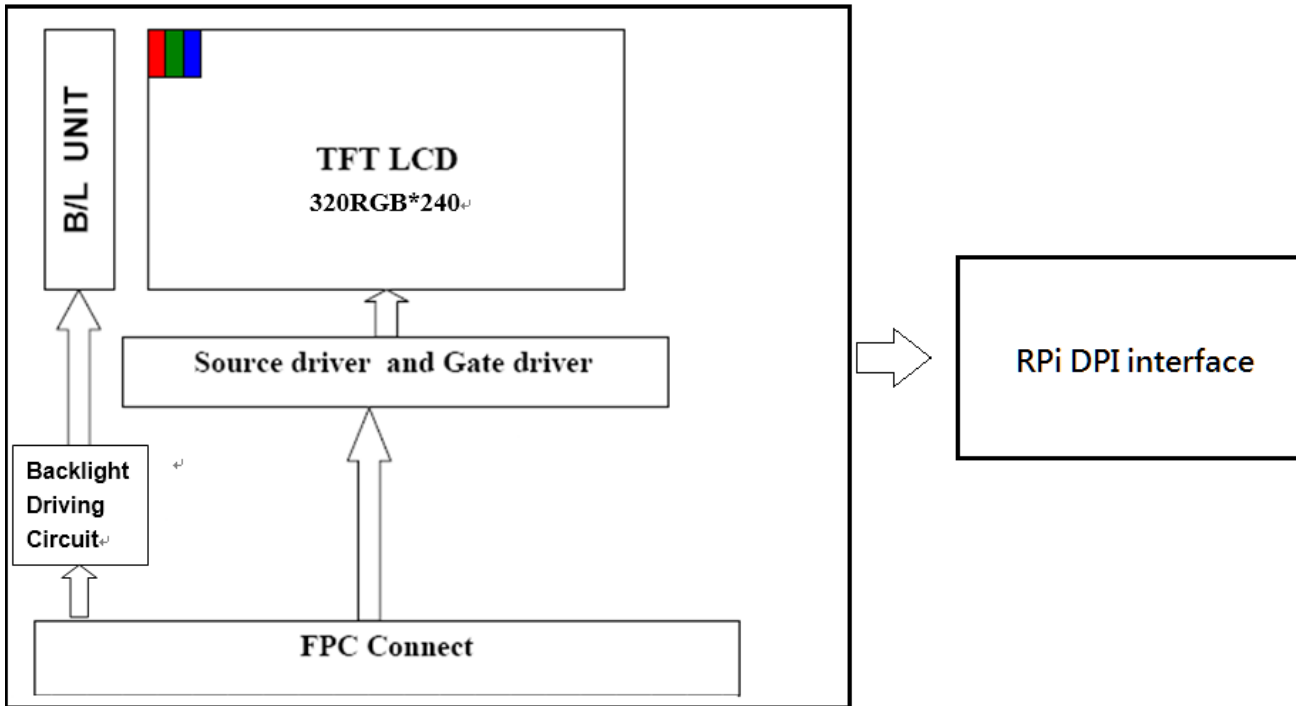

2.2 Interface Pin Description

2.2.1 (J1: DPI Interface)

Pin#	Name	Description
1	VCC	Power input for 3.3v
2	VDD	Power input for 5v
3	VS	Vertical Synchronization Signal
4	VDD	Power input for 5v
5	HS	Horizontal Synchronization Signal
6	GND	Power Ground.
7	B2	Blue Data
8	G0/G6	Green Data
9	GND	Power Ground.
10	G1/G7	Green Data
11	R3	Red Data
12	R4	Red Data
13	GPIO_A/PWM	RPi GPIO 27/ Backlight PWM
14	GND	Power Ground.
15	GPIO_B/CTP_INT	RPi GPIO 22 / PCTP Interrupt
16	GPIO_C/CTP_SCL	RPi GPIO 23 / I ² C Serial Clock Line
17	VCC	Power input for 3.3v
18	GPIO_D/CTP_SDA	RPi GPIO 24 / I ² C Serial Data Line
19	G2	Green Data
20	GND	Power Ground.

Pin#	Name	Description
21	B1/B7	Blue Data
22	GPIO_E	RPi GPIO 25
23	G3	Green Data
24	B0/B6	Blue Data
25	GND	Power Ground.
26	B5	Blue Data
27	PCLK	Peripheral Clock
28	DE	Data Enable
29	B3	Blue Data
30	GND	Power Ground.
31	B4	Blue Data
32	G4	Green Data
33	G5	Green Data
34	GND	Power Ground.
35	R5	Red Data
36	R2	Red Data
37	GPIO_F	RPi GPIO 26
38	R0/R6	Red Data
39	GND	Power Ground.
40	R1/R7	Red Data

2.2.2 (J2: GPIO Interface)

Pin#	Name	Description
1	VDD	Power output for 5v
2	GPIO_A/PWM	RPi GPIO 27/ Backlight PWM
3	VDD	Power output for 5v
4	GPIO_B/CTP_INT	RPi GPIO 22 / PCTP Interrupt
5	VCC	Power output for 3.3v
6	GPIO_C/CTP_SCL	RPi GPIO 23 / I ² C Serial Clock Line
7	VCC	Power output for 3.3v
8	GPIO_D/CTP_SDA	RPi GPIO 24 / I ² C Serial Data Line
9	GND	Power Ground
10	GPIO_E	RPi GPIO 25
11	GND	Power Ground
12	GPIO_F	RPi GPIO 26

2.3 Timing Characteristics

2.3.1 AC Characteristics

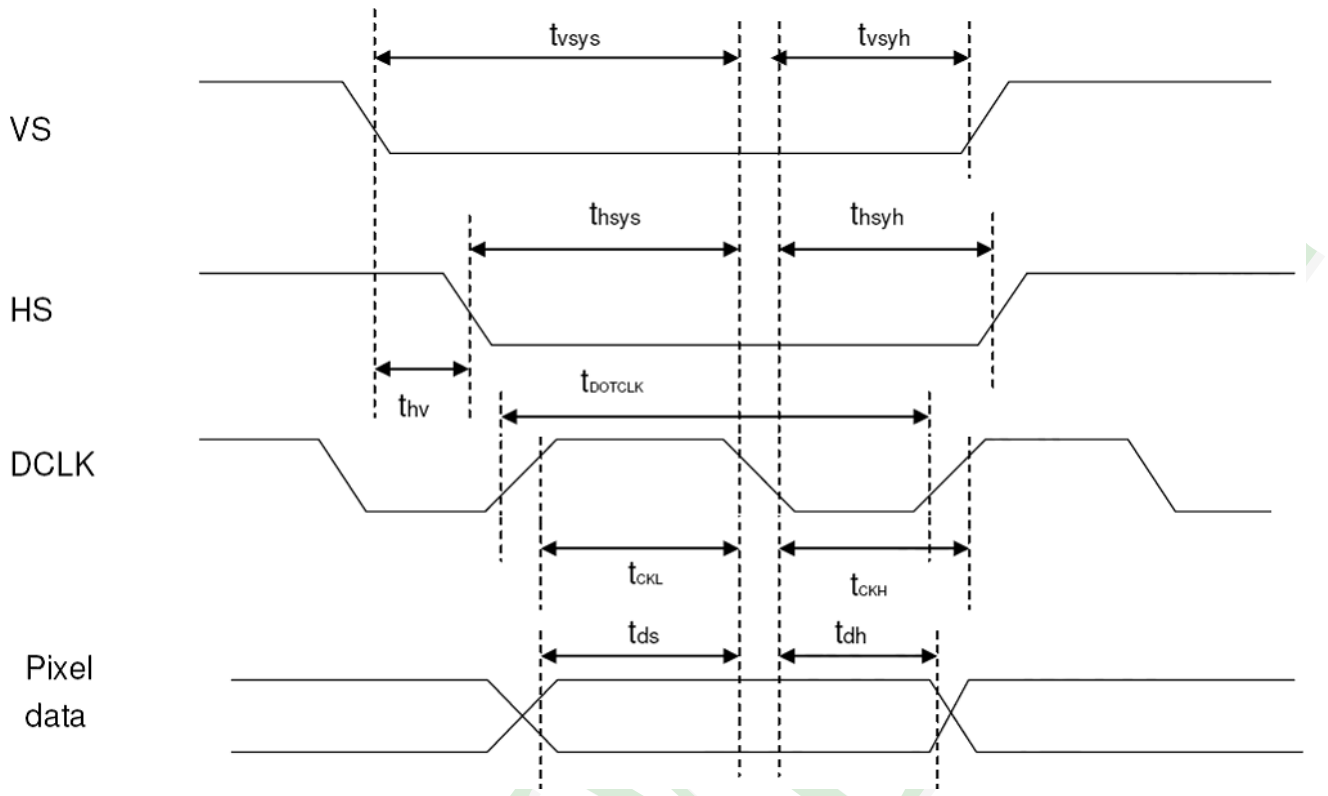

Characteristics	Symbol	Min.		Typ.		Max.		Unit
		24-bit	8-bit	24-bit	8-bit	24-bit	8-bit	
DOTCLK Frequency	fDOTCLK	-	-	6.5	19.5	10	30	MHz
DOTCLK Period	tDOTCLK	100	33.3	154	51.3	-	-	ns
Vertical Sync Setup Time	tvsys	20	10	-	-	-	-	ns
Vertical Sync Hold Time	tvsyh	20	10	-	-	-	-	ns
Horizontal Sync Setup Time	thsys	20	10	-	-	-	-	ns
Horizontal Sync Hold Time	thsyh	20	10	-	-	-	-	ns
Phase difference of Sync Signal Falling Edge	thv	1		-		240		tDOTCLK
DOTCLK Low Period	tCKL	50	15	-	-	-	-	ns
DOTCLK High Period	tCKH	50	15	-	-	-	-	ns
Data Setup Time	tds	12	10	-	-	-	-	ns
Data hold Time	tdh	12	10	-	-	-	-	ns
Reset pulse width	tRES	10		-		-		μ s

Note: External clock source must be provided to DOTCLK pin of HX8238-D. The driver will not operate if absent of the clocking signal.



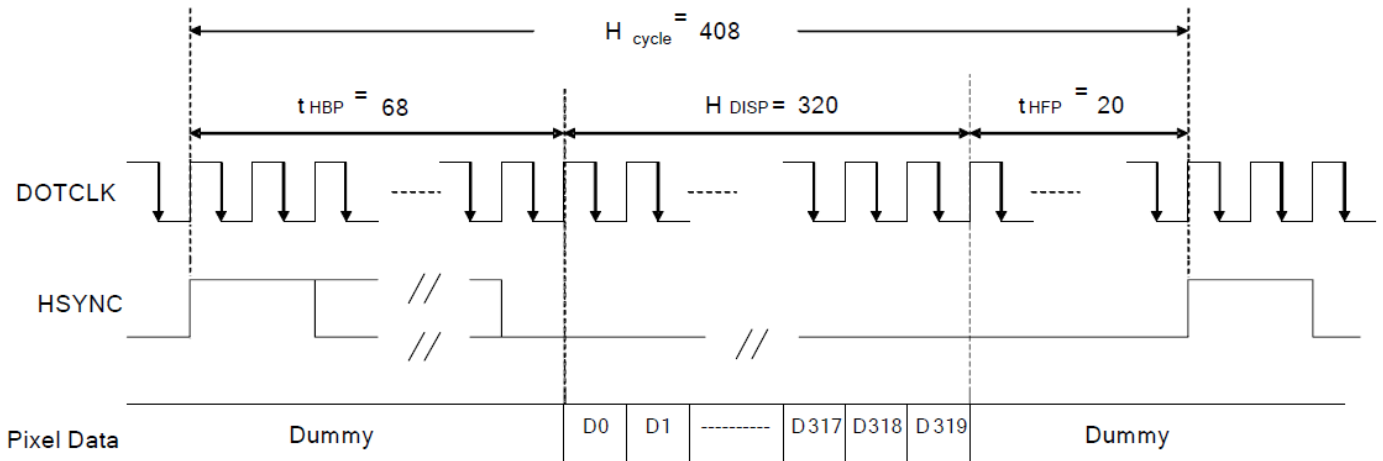

(a) Horizontal Data Transaction Timing

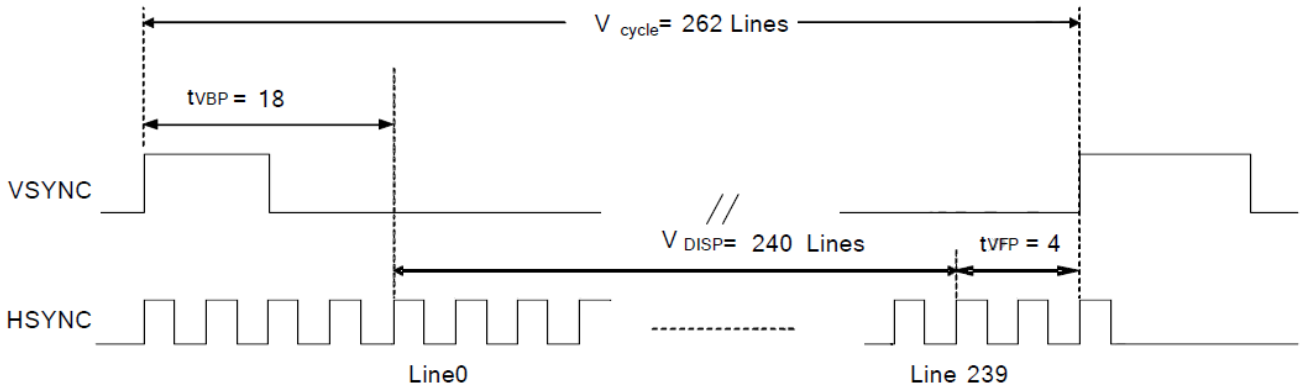

(b) Vertical Data Transaction Timing

Data transaction timing in parallel RGB (24-bit) interface (SYNC mode)

Characteristics	Symbol	Min.		Typ.		Max.		Unit
		24-bit	8-bit	24-bit	8-bit	24-bit	8-bit	
DOTCLK Frequency	f _{DOTCLK}	-	-	6.5	19.5	10	30	MHz
DOTCLK Period	t _{DOTCLK}	100	33.3	154	51.3	-	-	ns
Horizontal Frequency (Line)	f _H	-	-	14.9		22.35		KHz
Vertical Frequency (Refresh)	f _V	-	-	60		90		Hz
Horizontal Back Porch	t _{HBP}	-	-	68	204	-	-	t _{DOTCLK}
Horizontal Front Porch	t _{HFP}	-	-	20	60	-	-	t _{DOTCLK}
Horizontal Data Start Point	t _{HBP}	-	-	68	204	-	-	t _{DOTCLK}
Horizontal Blanking Period	t _{HBP} + t _{HFP}	52	146	88	264	180	960	t _{DOTCLK}
Horizontal Display Area	H _{DISP}	-	-	320	960	-	-	t _{DOTCLK}
Horizontal Cycle	H _{cycle}	372	1106	408	1224	500	1920	t _{DOTCLK}
Vertical Back Porch	t _{VBP}	-	-	18		-		Lines
Vertical Front Porch	t _{VFP}	-	-	4		-		Lines
Vertical Data Start Point	t _{VBP}	-	-	18		-		Lines
Vertical Blanking Period	NTSC	10		22		47		Lines
	PAL	20		33		120		
	PAL	12		25		112		
Vertical Display Area	NTSC	-		240		-		Lines
	PAL	-		280(PALM=0)		-		
	PAL	-		288(PALM=1)		-		
Vertical Cycle	NTSC	250		262		287		Lines
	PAL	300		313		400		

Data transaction timing in normal operating mode

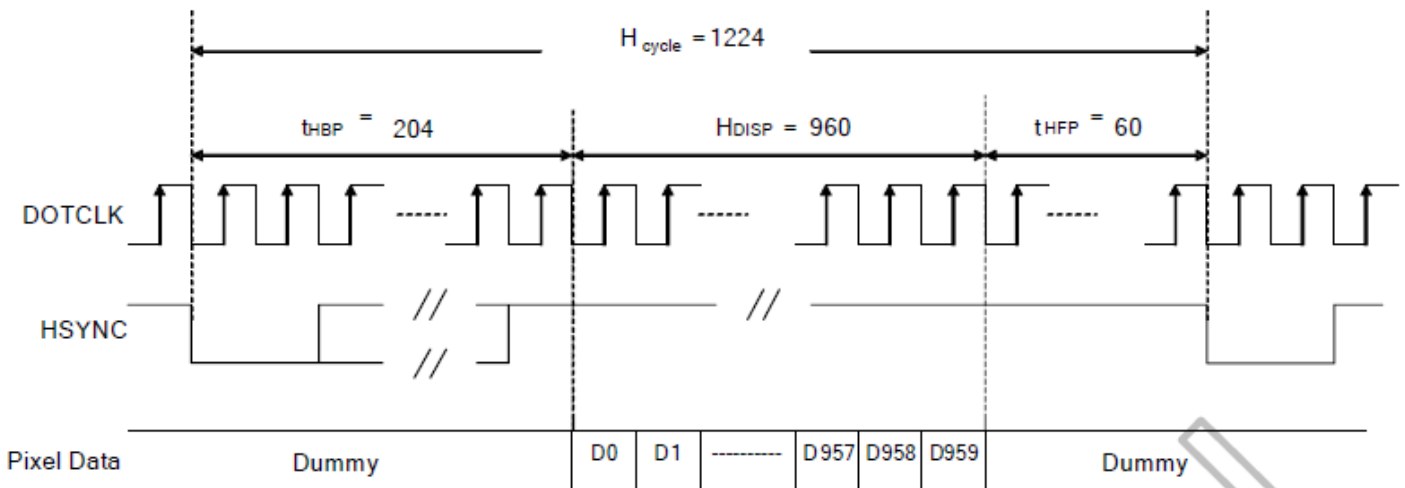

(1) Horizontal Data Transaction Timing

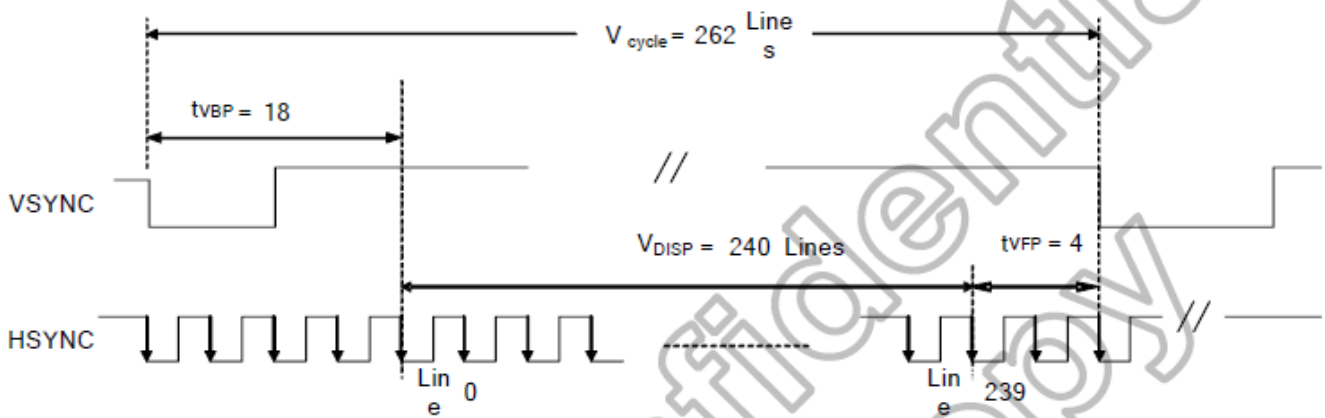

(2) Vertical Data Transaction Timing

Data transaction timing in parallel RGB (8-bit) interface (SYNC mode)

Characteristics	Symbol	Min.		Typ.		Max.		Unit
		24-bit	8-bit	24-bit	8-bit	24-bit	8-bit	
DOTCLK Frequency	f _{DOTCLK}	-	-	6.5	19.5	10	30	MHz
DOTCLK Period	t _{DOTCLK}	100	33.3	154	51.3	-	-	ns
Horizontal Blanking Period	t _{HBP} + t _{HFP}	52	146	88	264	180	960	t _{DOTCLK}
Horizontal Display Area	H _{DISP}	-	-	320	960	-	-	t _{DOTCLK}
Horizontal Cycle	H _{cycle}	372	1106	408	1224	500	1920	t _{DOTCLK}
Vertical Blanking Period	t _{VBP} + t _{VFP}	2	-	-	-	47	-	Lines
Vertical Display Area	V _{DISP}	-	-	240	-	-	-	Lines
Vertical Cycle	V _{cycle}	242	-	-	-	287	-	Lines

Data transaction timing in DE only operating mode

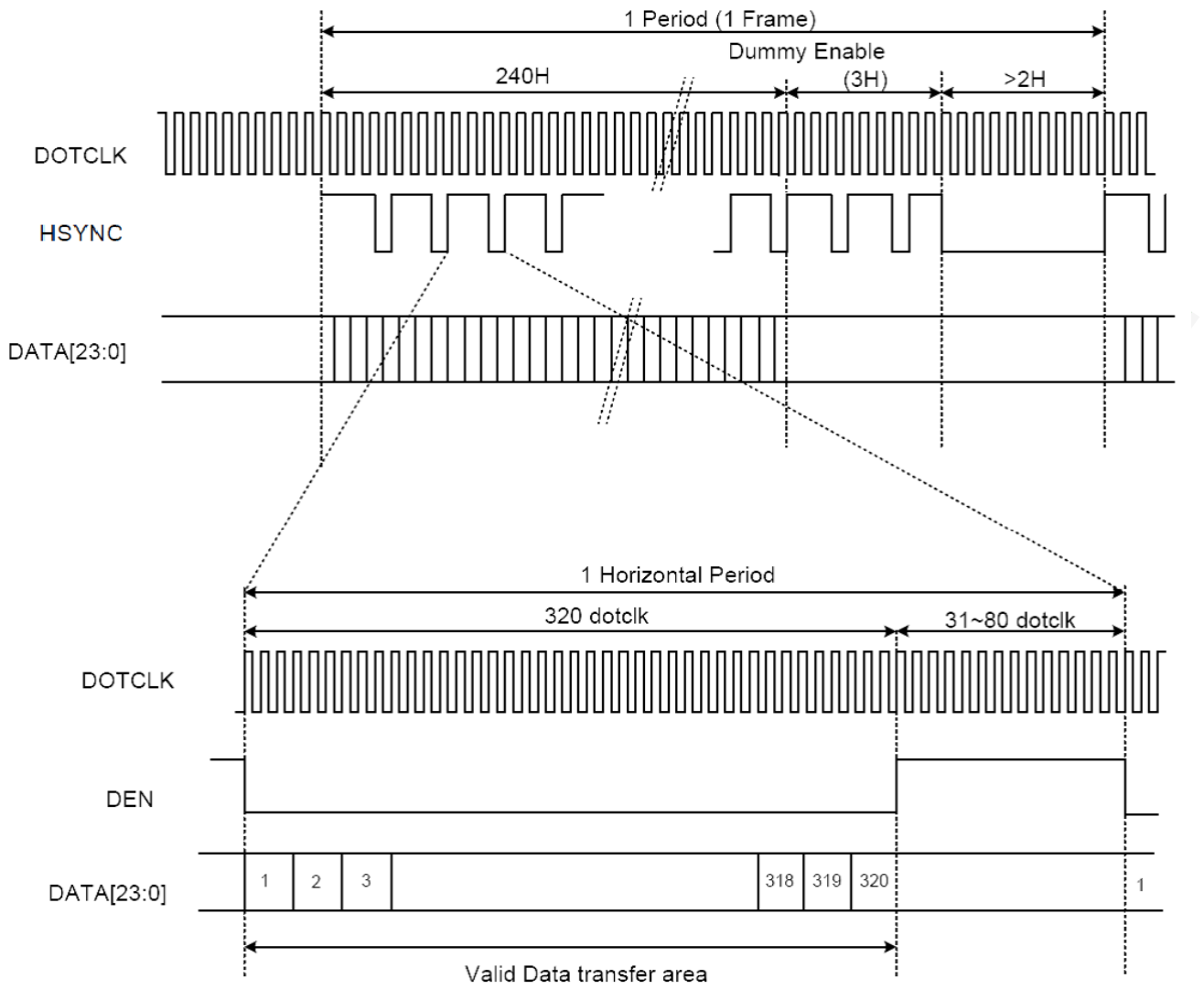

Signal timing in DE mode



• Write SPI

First Transmission (Register)

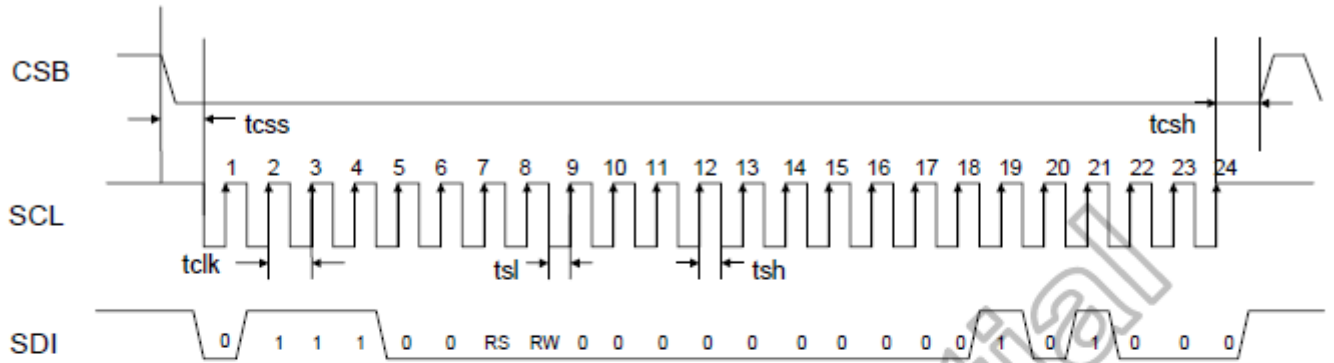

Second Transmission (Data)

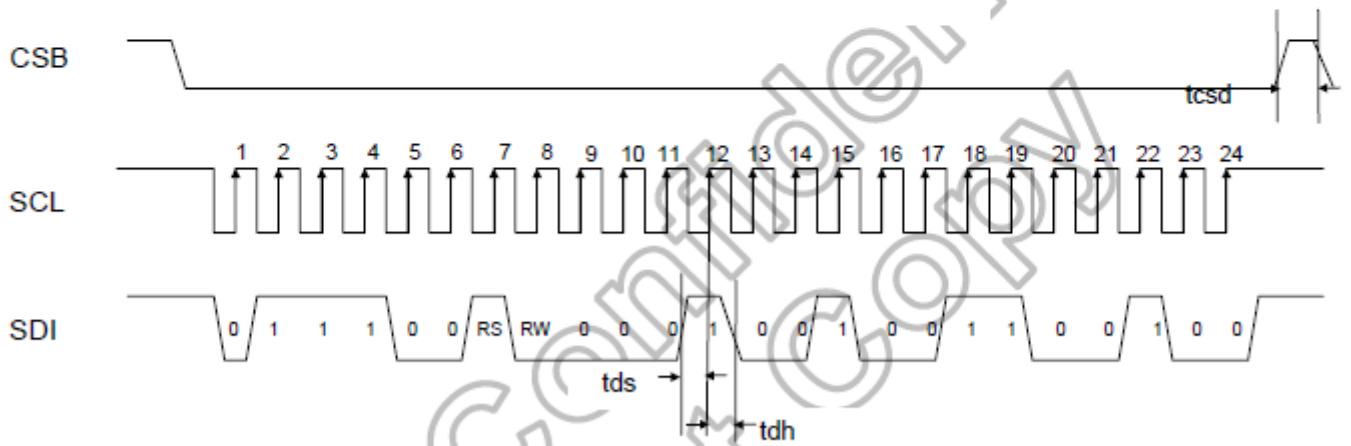

Note: The example writes "0x1264h" to register R28h.
SPID connected to VSS.

(a) SPI interface timing diagram & write SPI example

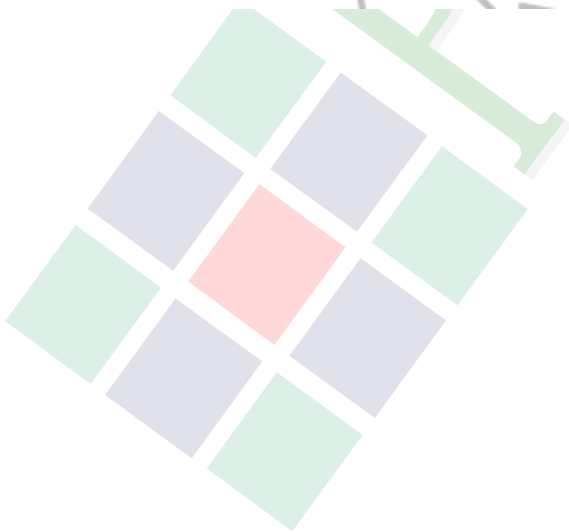

• Read SPI

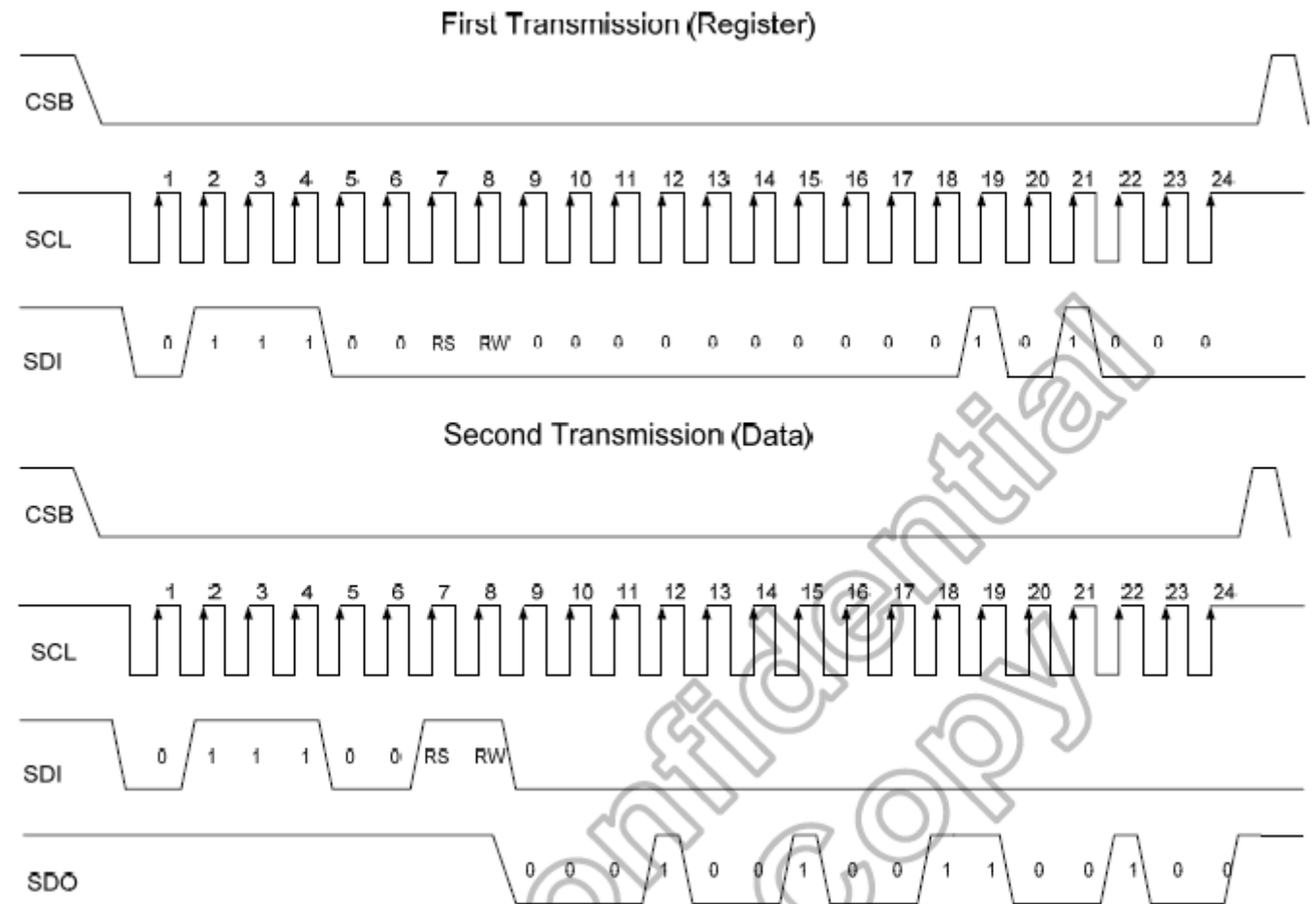

Note: The example Read "0x1264h" from register R28h.

(b) SPI interface timing diagram & read SPI example

Characteristics	Symbol	Spec.			Unit
		Min.	Typ.	Max.	
Serial Clock Frequency	fclk	-	-	20	MHz
Serial Clock Cycle Time	tclk	50	-	-	ns
Clock Low Width	tsl	25	-	-	ns
Clock High Width	tsh	25	-	-	ns
Clock Rising Time	trs	-	-	30	ns
Clock Falling Time	tfl	-	-	30	ns
Chip Select Hold Time	tcsh	10	-	-	ns
Chip Select High Delay Time	tcsd	20	-	-	ns
Data Setup Time	tds	5	-	-	ns
Data Hold Time	tdh	10	-	-	ns

SPI timing

2.4 Power Sequence

2.4.1 Power up sequence

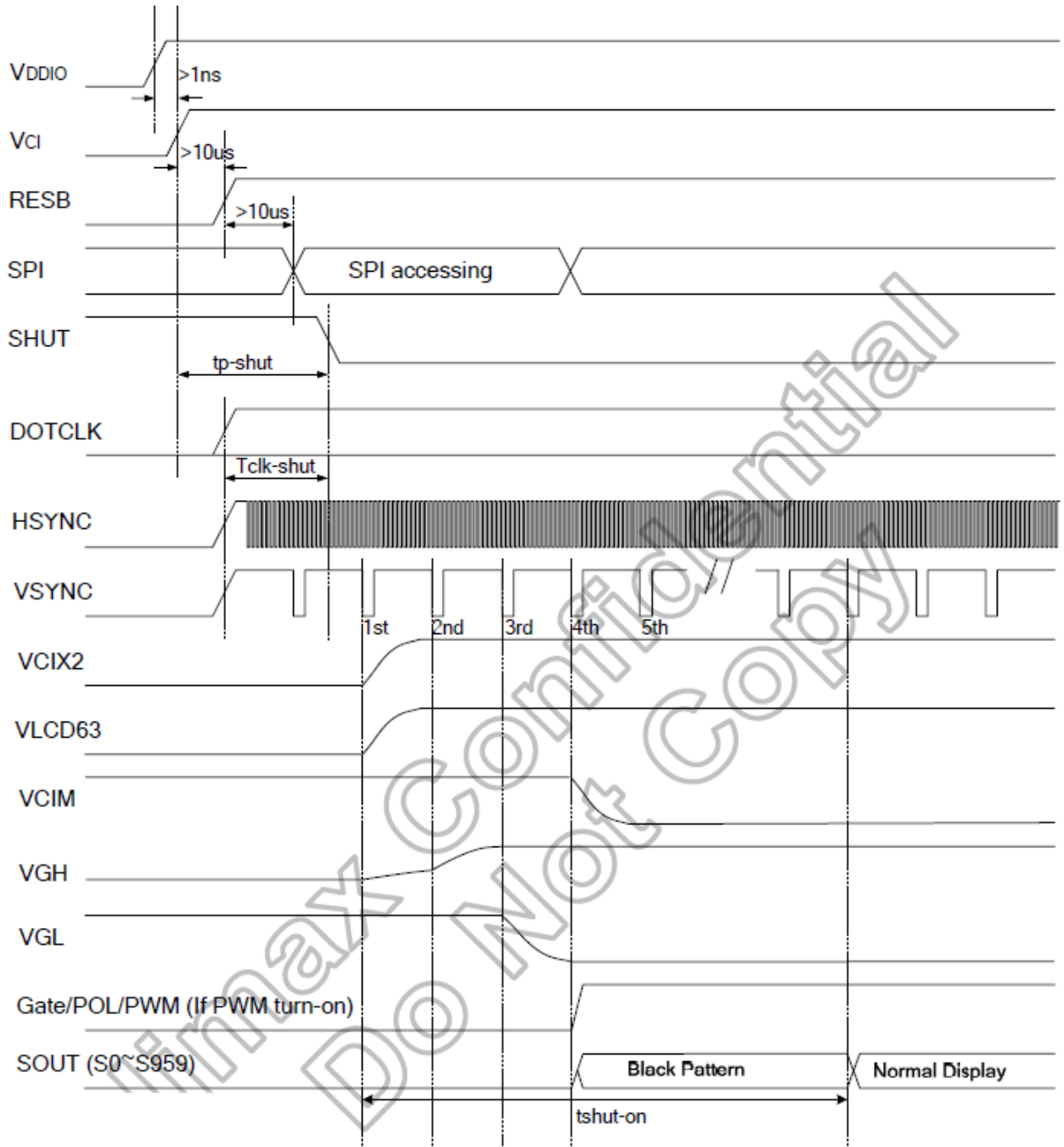

Power up sequence

2.4.2 Power down sequence

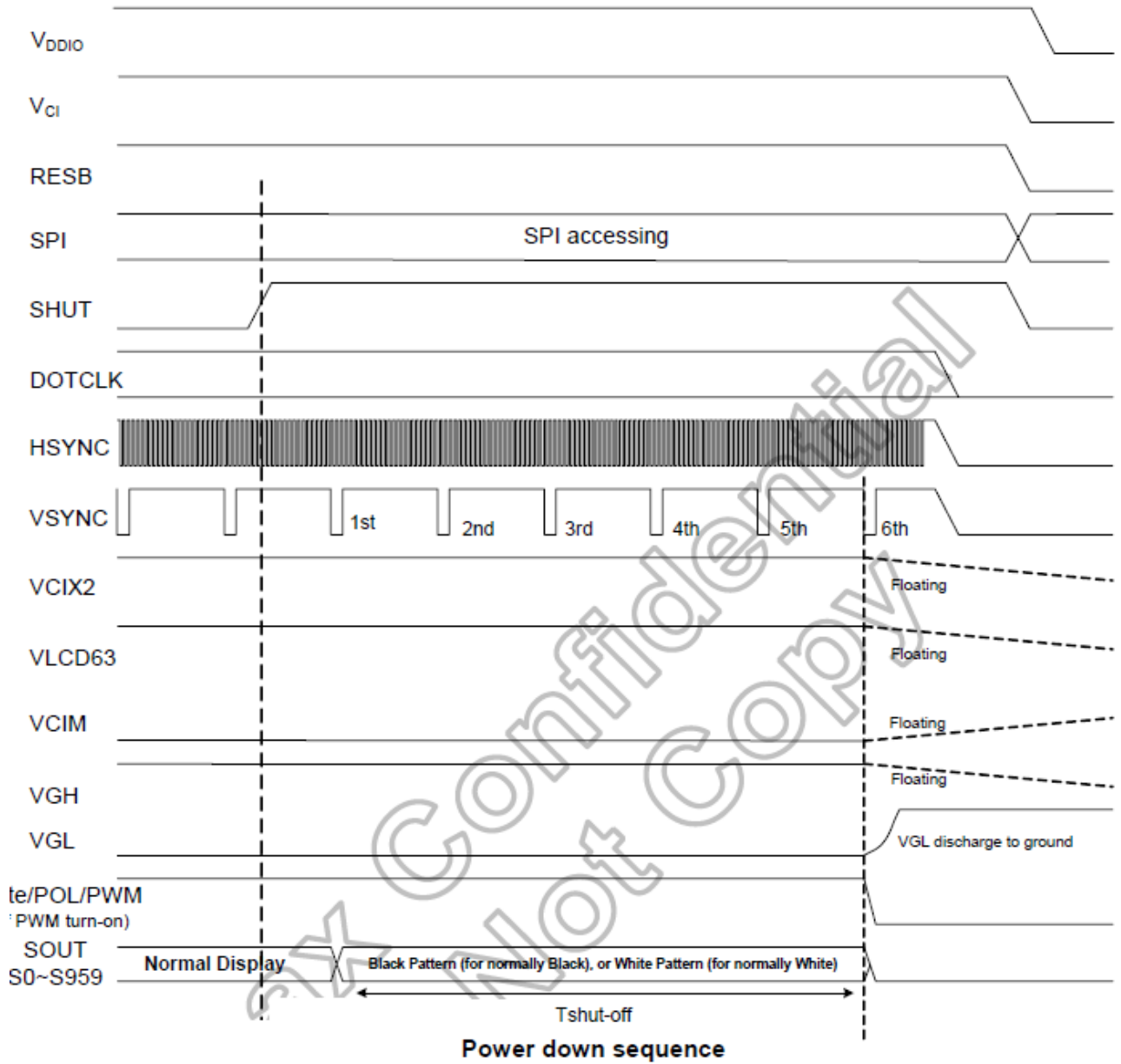

3. QUALITY ASSURANCE SYSTEM

3.1 Quality Assurance Flow Chart

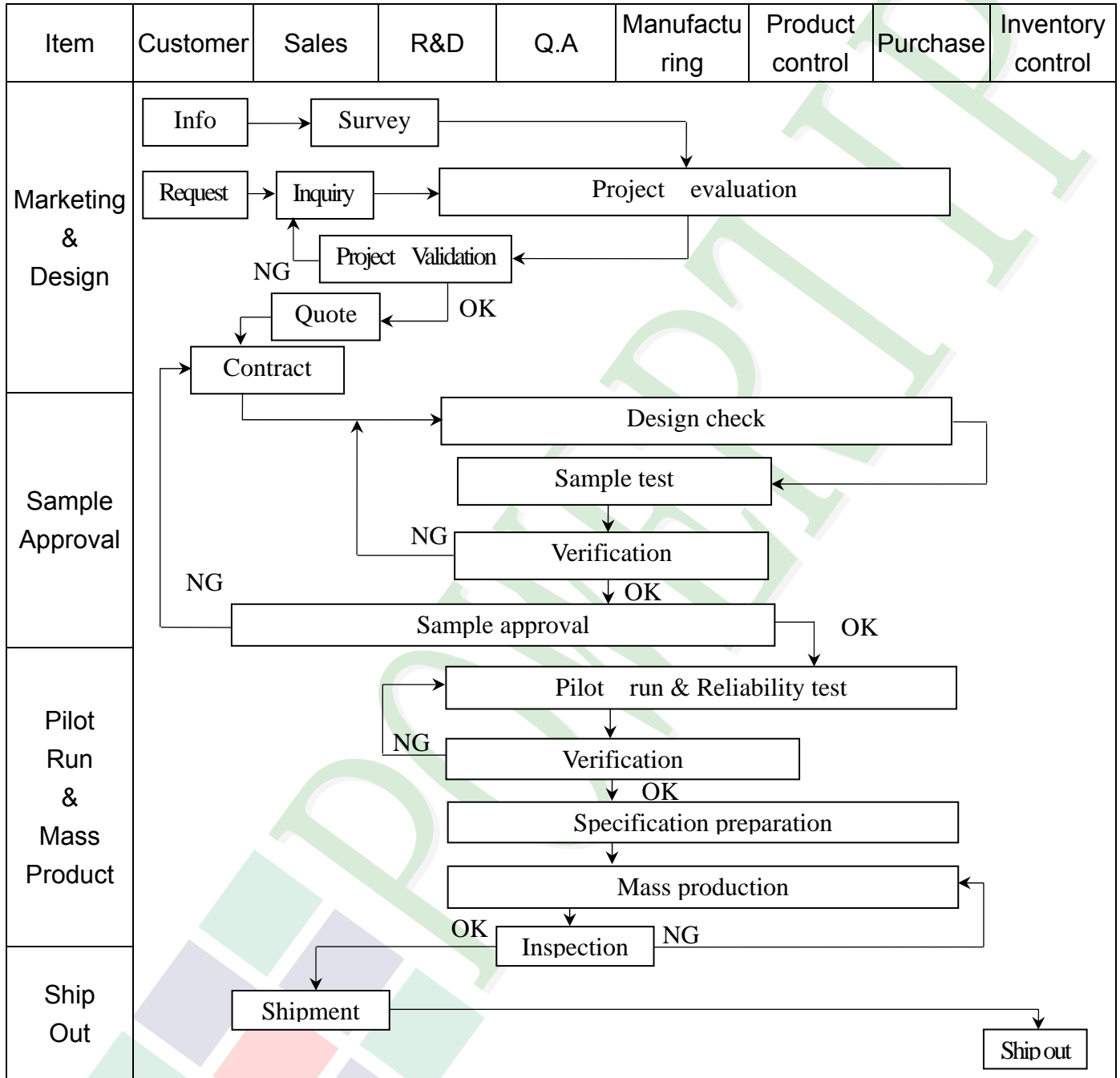

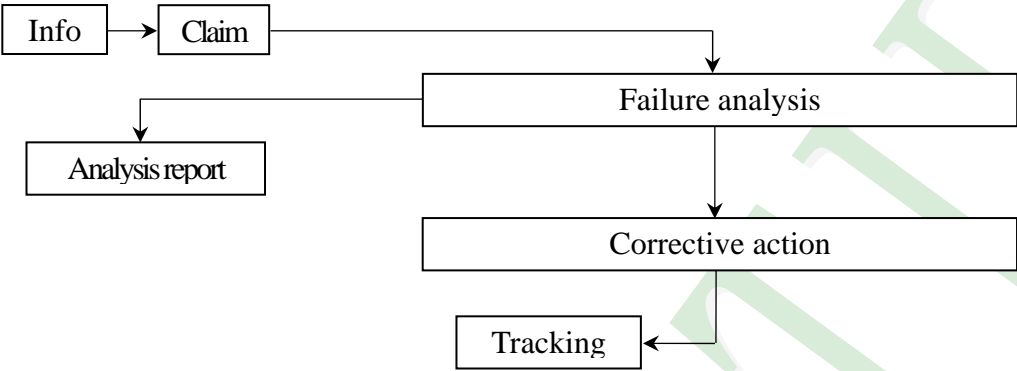
Item	Customer	Sales	R&D	Q.A	Manufacturing	Product control	Purchase	Inventory control
Sales Service	 <pre> graph TD Info[Info] --> Claim[Claim] Claim --> FA[Failure analysis] FA --> AR[Analysis report] FA --> CA[Corrective action] CA --> Tracking[Tracking] </pre>							
Q.A Activity	1. ISO 9001 Maintenance Activities 3. Equipment calibration 5. Standardization Management				2. Process improvement proposal 4. Education And Training Activities			

3.2. Inspection Specification

- ◆Scope: The document shall be applied to TFT-LCD Module for 3.5" -15" (Ver.B01).
- ◆Inspection Standard: MIL-STD-105E Table Normal Inspection Single Sampling Level II.
- ◆Equipment: Gauge, MIL-STD, Powertip Tester, Sample
- ◆Defect Level: Major Defect AQL: 0.4; Minor Defect AQL: 1.5
- ◆OUT Going Defect Level: Sampling.
- ◆Standard of the product appearance test:

a. Manner of appearance test:

- (1). The test best be under 20W×2 fluorescent light(about 300lux ~500lux)
 , and distance of view must be at 30~40 cm.
- (2). The test direction is base on about around 45° of vertical line.

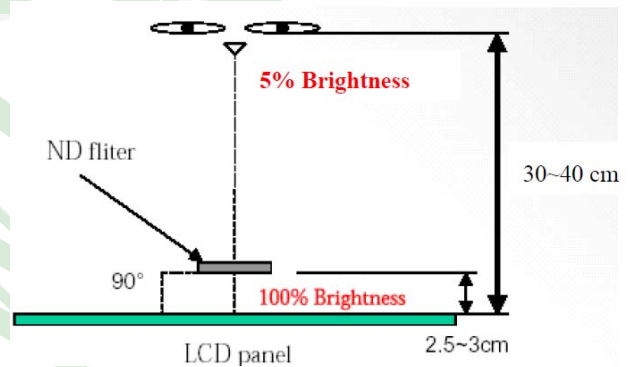
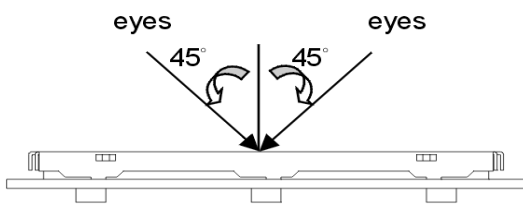

(3). Definition of area.

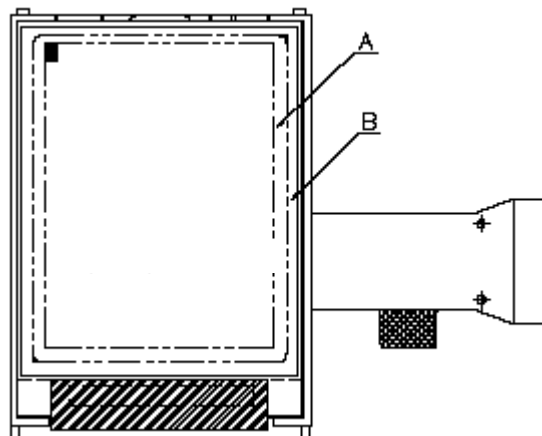

A area: viewing area

B area: Outside of viewing area

(4). Standard of inspection : (Unit : mm)

◆ Specification For TFT-LCD Module 3.5" ~15" :

(Ver.B01)

NO	Item	Criterion	Level												
01	Product condition	1. 1 The part number is inconsistent with work order of production.	Major												
		1. 2 Mixed product types.	Major												
		1. 3 Assembled in inverse direction.	Major												
02	Quantity	2. 1 The quantity is inconsistent with work order of production.	Major												
03	Outline dimension	3. 1 Product dimension and structure must conform to structure diagram.	Major												
04	Electrical Testing	4. 1 Missing line character and icon.	Major												
		4. 2 No function or no display.	Major												
		4. 3 Display malfunction.	Major												
		4. 4 LCD viewing angle defect.	Major												
		4. 5 Current consumption exceeds product specifications.	Major												
		4. 6 Mura cannot be seen through 5% ND filter at 50% Gray, should be judged by the viewing angle of 90 degree.	Minor												
05	Dot defect (Bright dot, Dark dot) On -display	<table border="1"> <thead> <tr> <th></th> <th>Item</th> <th>Acceptance (Q'ty)</th> </tr> </thead> <tbody> <tr> <td rowspan="4">Dot Defect</td> <td>Bright Dot</td> <td>≦ 4</td> </tr> <tr> <td>Dark Dot</td> <td>≦ 5</td> </tr> <tr> <td>Joint Dot</td> <td>≦ 3</td> </tr> <tr> <td>Total</td> <td>≦ 7</td> </tr> </tbody> </table>		Item	Acceptance (Q'ty)	Dot Defect	Bright Dot	≦ 4	Dark Dot	≦ 5	Joint Dot	≦ 3	Total	≦ 7	Minor
			Item	Acceptance (Q'ty)											
		Dot Defect	Bright Dot	≦ 4											
			Dark Dot	≦ 5											
			Joint Dot	≦ 3											
Total	≦ 7														
5. 1 Inspection pattern: full white, full black, Red, Green and blue screens.															
5. 2 It is defined as dot defect if defect area > 1/2 dot.															
5. 3 The distance between two dot defect ≧ 5 mm.															
5. 4 Bright dot that can not be seen through 5% ND filter.															

◆ Specification For TFT-LCD Module 3.5" ~15" :

(Ver.B01)

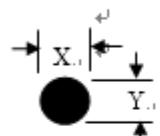
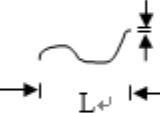
NO	Item	Criterion	Level																																																							
06	<p>Black or white Dot, scratch, contamination</p> <p>Round type</p>  <p>$\Phi = (x + y) / 2$</p> <p>Line type</p> 	<p>6.1 Round type (Non-display or display):</p> <table border="1"> <thead> <tr> <th rowspan="2">Dimension (diameter : Φ)</th> <th colspan="2">Acceptance (Q'ty)</th> </tr> <tr> <th>A area</th> <th>B area</th> </tr> </thead> <tbody> <tr> <td>$\Phi \leq 0.25$</td> <td>Ignore</td> <td rowspan="4">Ignore</td> </tr> <tr> <td>$0.25 < \Phi \leq 0.50$</td> <td>5</td> </tr> <tr> <td>$\Phi > 0.50$</td> <td>0</td> </tr> <tr> <td>Total</td> <td>5</td> </tr> </tbody> </table> <p>6.2 Line type(Non-display or display):</p> <table border="1"> <thead> <tr> <th rowspan="2">module size</th> <th rowspan="2">Length (L)</th> <th rowspan="2">Width (W)</th> <th colspan="2">Acceptance (Q'ty)</th> </tr> <tr> <th>A area</th> <th>B area</th> </tr> </thead> <tbody> <tr> <td rowspan="4">3.5" to less 9"</td> <td>---</td> <td>$W \leq 0.03$</td> <td>Ignore</td> <td rowspan="4">Ignore</td> </tr> <tr> <td>$L \leq 10.0$</td> <td>$0.03 < W \leq 0.05$</td> <td>4</td> </tr> <tr> <td>$L \leq 5.0$</td> <td>$0.05 < W \leq 0.10$</td> <td>2</td> </tr> <tr> <td>---</td> <td>$W > 0.10$</td> <td>As round type</td> </tr> <tr> <td colspan="3">Total</td> <td>5</td> <td></td> </tr> <tr> <td rowspan="4">9" to 15"</td> <td>---</td> <td>$W \leq 0.05$</td> <td>Ignore</td> <td rowspan="4">Ignore</td> </tr> <tr> <td>$L \leq 10.0$</td> <td>$0.05 < W \leq 0.10$</td> <td>5</td> </tr> <tr> <td>---</td> <td>$W > 0.10$</td> <td>As round type</td> </tr> <tr> <td colspan="3">Total</td> <td>5</td> </tr> </tbody> </table>	Dimension (diameter : Φ)	Acceptance (Q'ty)		A area	B area	$\Phi \leq 0.25$	Ignore	Ignore	$0.25 < \Phi \leq 0.50$	5	$\Phi > 0.50$	0	Total	5	module size	Length (L)	Width (W)	Acceptance (Q'ty)		A area	B area	3.5" to less 9"	---	$W \leq 0.03$	Ignore	Ignore	$L \leq 10.0$	$0.03 < W \leq 0.05$	4	$L \leq 5.0$	$0.05 < W \leq 0.10$	2	---	$W > 0.10$	As round type	Total			5		9" to 15"	---	$W \leq 0.05$	Ignore	Ignore	$L \leq 10.0$	$0.05 < W \leq 0.10$	5	---	$W > 0.10$	As round type	Total			5	Minor
Dimension (diameter : Φ)	Acceptance (Q'ty)																																																									
	A area	B area																																																								
$\Phi \leq 0.25$	Ignore	Ignore																																																								
$0.25 < \Phi \leq 0.50$	5																																																									
$\Phi > 0.50$	0																																																									
Total	5																																																									
module size	Length (L)	Width (W)	Acceptance (Q'ty)																																																							
			A area	B area																																																						
3.5" to less 9"	---	$W \leq 0.03$	Ignore	Ignore																																																						
	$L \leq 10.0$	$0.03 < W \leq 0.05$	4																																																							
	$L \leq 5.0$	$0.05 < W \leq 0.10$	2																																																							
	---	$W > 0.10$	As round type																																																							
Total			5																																																							
9" to 15"	---	$W \leq 0.05$	Ignore	Ignore																																																						
	$L \leq 10.0$	$0.05 < W \leq 0.10$	5																																																							
	---	$W > 0.10$	As round type																																																							
	Total				5																																																					
07	Polarizer Bubble	<table border="1"> <thead> <tr> <th rowspan="2">Dimension (diameter: Φ)</th> <th colspan="2">Acceptance (Q'ty)</th> </tr> <tr> <th>A area</th> <th>B area</th> </tr> </thead> <tbody> <tr> <td>$\Phi \leq 0.25$</td> <td>Ignore</td> <td rowspan="5">Ignore</td> </tr> <tr> <td>$0.25 < \Phi \leq 0.50$</td> <td>4</td> </tr> <tr> <td>$0.50 < \Phi \leq 0.80$</td> <td>1</td> </tr> <tr> <td>$\Phi > 0.80$</td> <td>0</td> </tr> <tr> <td>Total</td> <td>5</td> </tr> </tbody> </table>	Dimension (diameter: Φ)	Acceptance (Q'ty)		A area	B area	$\Phi \leq 0.25$	Ignore	Ignore	$0.25 < \Phi \leq 0.50$	4	$0.50 < \Phi \leq 0.80$	1	$\Phi > 0.80$	0	Total	5	Minor																																							
Dimension (diameter: Φ)	Acceptance (Q'ty)																																																									
	A area	B area																																																								
$\Phi \leq 0.25$	Ignore	Ignore																																																								
$0.25 < \Phi \leq 0.50$	4																																																									
$0.50 < \Phi \leq 0.80$	1																																																									
$\Phi > 0.80$	0																																																									
Total	5																																																									

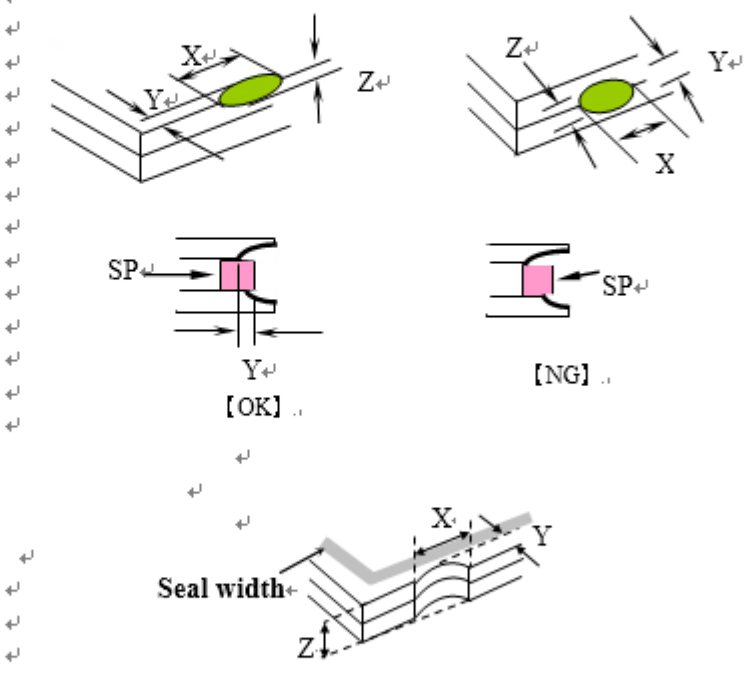
NO	Item	Criterion	Level									
08	The crack of glass	<p>Symbols :</p> <p>X: The length of crack Y: The width of crack Z: The thickness of crack t: The thickness of glass W: terminal length a: LCD side length</p> <p>8.1 General glass chip: 8.1.1 Chip on panel surface and crack between panels:</p>  <table border="1" data-bbox="566 1444 1292 1713"> <thead> <tr> <th>X</th> <th>Y</th> <th>Z</th> </tr> </thead> <tbody> <tr> <td>$\leq a$</td> <td>Crack can't enter viewing area</td> <td>$\leq 1/2 t$</td> </tr> <tr> <td>$\leq a$</td> <td>Crack can't exceed the half of SP width</td> <td>$1/2 t < Z \leq t$</td> </tr> </tbody> </table>	X	Y	Z	$\leq a$	Crack can't enter viewing area	$\leq 1/2 t$	$\leq a$	Crack can't exceed the half of SP width	$1/2 t < Z \leq t$	Minor
X	Y	Z										
$\leq a$	Crack can't enter viewing area	$\leq 1/2 t$										
$\leq a$	Crack can't exceed the half of SP width	$1/2 t < Z \leq t$										

◆ Specification For TFT-LCD Module 3.5" ~15" :

(Ver.B01)

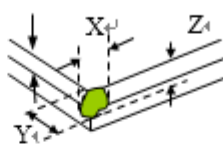
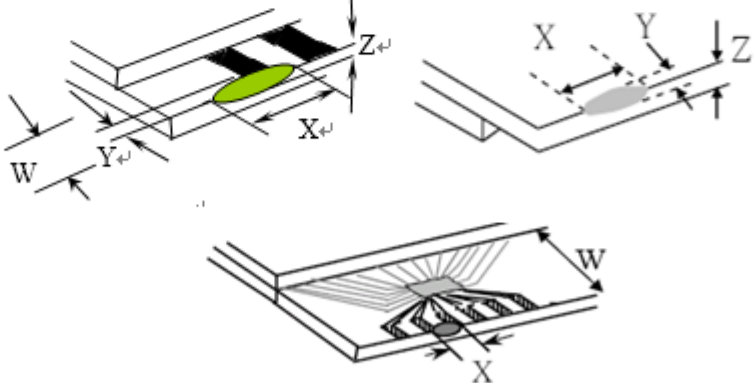
NO	Item	Criterion	Level												
08	The crack of glass	<p>Symbols :</p> <p>X: The length of crack Y: The width of crack</p> <p>Z: The thickness of crack W: terminal length</p> <p>t: The thickness of glass a: LCD side length</p> <hr/> <p>8.1.2 Corner crack:</p>  <table border="1" data-bbox="555 721 1284 985"> <thead> <tr> <th>X</th> <th>Y</th> <th>Z</th> </tr> </thead> <tbody> <tr> <td>$\leq 1/5 a$</td> <td>Crack can't enter viewing area</td> <td>$Z \leq 1/2 t$</td> </tr> <tr> <td>$\leq 1/5 a$</td> <td>Crack can't exceed the half of SP width.</td> <td>$1/2 t < Z \leq 2 t$</td> </tr> </tbody> </table>	X	Y	Z	$\leq 1/5 a$	Crack can't enter viewing area	$Z \leq 1/2 t$	$\leq 1/5 a$	Crack can't exceed the half of SP width.	$1/2 t < Z \leq 2 t$				
		X	Y	Z											
$\leq 1/5 a$	Crack can't enter viewing area	$Z \leq 1/2 t$													
$\leq 1/5 a$	Crack can't exceed the half of SP width.	$1/2 t < Z \leq 2 t$													
		<p>8.2 Protrusion over terminal:</p> <p>8.2.1 Chip on electrode pad:</p>  <table border="1" data-bbox="587 1556 1292 1713"> <thead> <tr> <th></th> <th>X</th> <th>Y</th> <th>Z</th> </tr> </thead> <tbody> <tr> <td>Front</td> <td>$\leq a$</td> <td>$\leq 1/2 W$</td> <td>$\leq t$</td> </tr> <tr> <td>Back</td> <td>$\leq a$</td> <td>$\leq W$</td> <td>$\leq 1/2 t$</td> </tr> </tbody> </table>		X	Y	Z	Front	$\leq a$	$\leq 1/2 W$	$\leq t$	Back	$\leq a$	$\leq W$	$\leq 1/2 t$	Minor
	X	Y	Z												
Front	$\leq a$	$\leq 1/2 W$	$\leq t$												
Back	$\leq a$	$\leq W$	$\leq 1/2 t$												

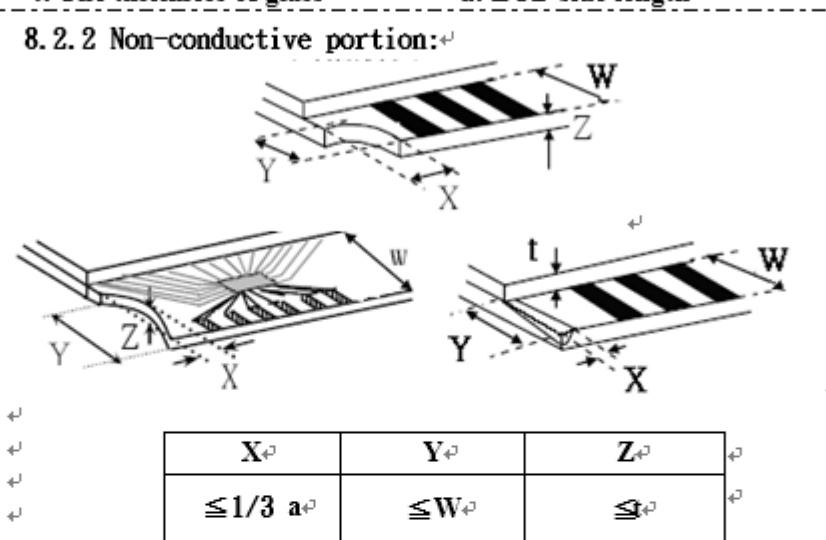
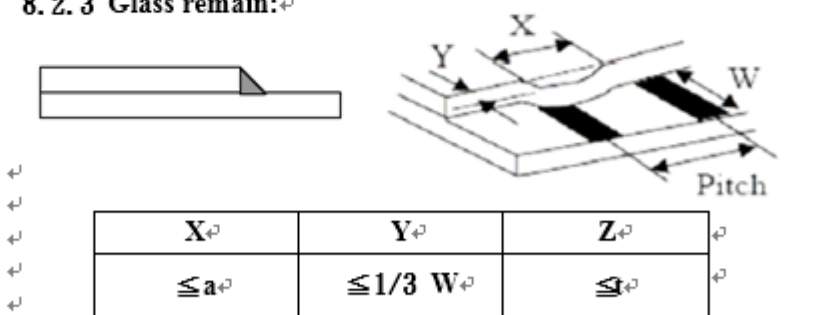
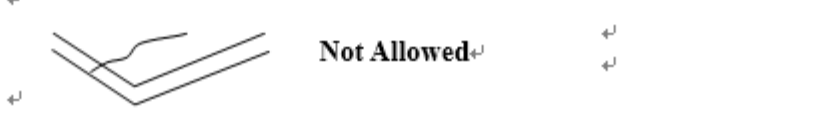
NO	Item	Criterion	Level
08	The crack of glass	<p>Symbols:</p> <p>X: The length of crack Y: The width of crack</p> <p>Z: The thickness of crack W: terminal length</p> <p>t: The thickness of glass a: LCD side length</p> <hr/> <p>8.2.2 Non-conductive portion:</p>  <p>8.2.3 Glass remain:</p>  <p>8.2.4 Cracking:</p> 	Minor

◆ Specification For TFT-LCD Module 3.5" ~15" :

(Ver.B01)

NO	Item	Criterion	Level
09	Backlight elements	9. 1 Backlight can't work normally.	Major
		9. 2 Backlight doesn't light or color is wrong.	Major
		9. 3 Illumination source flickers when lit.	Major
10	General appearance	10. 1 Pin type 、 quantity 、 dimension must match type in structure diagram.	Major
		10. 2 No short circuits in components on PCB or FPC.	Major
		10. 3 Parts on PCB or FPC must be: no wrong parts, missing parts or excess parts.	Major
		10. 4 Product packaging must the same as specified on packaging specification sheet.	Minor
		10. 5 The folding and peeled off in polarizer are not acceptable.	Minor
		10. 6 The PCB or FPC between B/L assembled distance(PCB or FPC) is ≤ 1.5 mm.	Minor

4. RELIABILITY TEST

4.1 Reliability Test Condition

(Ver.B01)

NO.	TEST ITEM	TEST CONDITION											
1	High Temperature Storage Test	Keep in +80 ±5°C 240 hrs											
2	Low Temperature Storage Test	Keep in -30 ±5°C 240 hrs											
3	High Temperature / High Humidity Storage Test	Keep in +60 °C / 90% R.H duration for 240 hrs (Excluding the polarizer)											
4	Temperature Cycling Storage Test	<p style="text-align: center;"> $-30^{\circ}\text{C} \xrightarrow{(30\text{mins})} +25^{\circ}\text{C} \xrightarrow{(5\text{mins})} +80^{\circ}\text{C} \xrightarrow{(30\text{mins})} +25^{\circ}\text{C} \xrightarrow{(5\text{mins})}$ 20 Cycle </p>											
5	ESD Test	Air Discharge: Apply 2 KV with 5 times Discharge for each polarity +/-	Contact Discharge: Apply 250 V with 5 times discharge for each polarity +/-										
		1.Temperature ambience : 15°C ~35°C 2.Humidity relative : 30% ~60% 3.Energy Storage Capacitance(Cs+Cd) : 150pF±10% 4.Discharge Resistance(Rd) : 330Ω±10% 5.Discharge, mode of operation : Single Discharge (time between successive discharges at least 1 sec) (Tolerance if the output voltage indication : ±5%)											
6	Vibration Test (Packaged)	1.Sine wave 10~55 Hz frequency (1 min/sweep) 2.The amplitude of vibration :1.5 mm 3.Each direction (X、Y、Z) duration for 2 Hrs											
7	Drop Test (Packaged)	<table border="1" style="margin-left: auto; margin-right: auto;"> <thead> <tr> <th>Packing Weight (Kg)</th> <th>Drop Height (cm)</th> </tr> </thead> <tbody> <tr> <td>0 ~ 45.4</td> <td>122</td> </tr> <tr> <td>45.4 ~ 90.8</td> <td>76</td> </tr> <tr> <td>90.8 ~ 454</td> <td>61</td> </tr> <tr> <td>Over 454</td> <td>46</td> </tr> </tbody> </table>	Packing Weight (Kg)	Drop Height (cm)	0 ~ 45.4	122	45.4 ~ 90.8	76	90.8 ~ 454	61	Over 454	46	
		Packing Weight (Kg)	Drop Height (cm)										
0 ~ 45.4	122												
45.4 ~ 90.8	76												
90.8 ~ 454	61												
Over 454	46												
		Drop Direction : ※1 corner / 3 edges / 6 sides each 1time											

◎Result Evaluation Criteria :

Under the display quality test conditions with normal operations with normal operation state. Do not change these conditions as such changes may affect practical display function.

(Normal operation state)

Temperature: +20~30°C

Humidity: 50~70%

Atmospheric pressure: 86~106Kpa

5. PRECAUTION RELATING PRODUCT HANDLING

5.1 SAFETY

- 5.1.1 If the LCD panel breaks , be careful not to get the liquid crystal to touch your skin.
- 5.1.2 If the liquid crystal touches your skin or clothes , please wash it off immediately by using soap and water.

5.2 HANDLING

- 5.2.1 Avoid any strong mechanical shock which can break the glass.
- 5.2.2 Avoid static electricity which can damage the CMOS LSI—When working with the module , be sure to ground your body and any electrical equipment you may be using.
- 5.2.3 Do not remove the panel or frame from the module.
- 5.2.4 The polarizing plate of the display is very fragile. So , please handle it very carefully ,do not touch , push or rub the exposed polarizing with anything harder than an HB pencil lead (glass , tweezers , etc.)
- 5.2.5 Do not wipe the polarizing plate with a dry cloth , as it may easily scratch the surface of plate.
- 5.2.6 Do not touch the display area with bare hands , this will stain the display area.
- 5.2.7 Do not use ketonics solvent & aromatic solvent. Use with a soft cloth soaked with a cleaning naphtha solvent.
- 5.2.8 To control temperature and time of soldering is $320\pm 10^{\circ}\text{C}$ and 3-5 sec.
- 5.2.9 To avoid liquid (include organic solvent) stained on LCM .

5.3 STORAGE

- 5.3.1 Store the panel or module in a dark place where the temperature is $25^{\circ}\text{C} \pm 5^{\circ}\text{C}$ and the humidity is below 65% RH.
- 5.3.2 Do not place the module near organics solvents or corrosive gases.
- 5.3.3 Do not crush , shake , or jolt the module.

5.4 TERMS OF WARRANTY

- 5.4.1 Applicable warrant period
The period is within thirteen months since the date of shipping out under normal using and storage conditions.
- 5.4.2 Unaccepted responsibility
This product has been manufactured to your company's specification as a part for use in your company's general electronic products. It is guaranteed to perform according to delivery specifications. For any other use apart from general electronic equipment , we cannot take responsibility if the product is used in nuclear power control equipment , aerospace equipment , fire and security systems or any other applications in which there is a direct risk to human life and where extremely high levels of reliability are required.

1. 包裝材料規格表 (Packaging Material) : (per carton)

No.	Item	Model	Dimensions (mm)	1Pcs Weight	Quantity	Total Weight
1	成品 (LCM)	PH320240T023-IHC09	84.02 X 75.36	0.0746	72	5.3712
2	氣泡袋(1)Bubble Bag	BAG0000000005	150 X 120	0.002	72	0.144
3	A2-1隔板(2)A2-1 Partition	BX29500072BZBA	295 X 72 X 3.0	0.0109	42	0.4578
4	B2-1隔板(4)B2-1 Partition	BX24500072BZBA	245 X 72 X 3.0	0.0094	18	0.1692
5	海綿墊(4)Foam Rubber Cushion	OTFOAM00006ABA	290 X 240 X 10	0.02	18	0.36
6	C3-3內盒(5)Product Box	BX31025511AABA	310 X 255 X 116	0.17	6	1.02
7	外紙箱(6)Carton	BX52732536CCBA	527 X 325 X 360	0.83	1	0.83
8						
9						

2. 一整箱總重量 (Total LCD Weight in carton) : 8.35 Kg±10%

3. 單箱數量規格表 (Packaging Specifications and Quantity) :

(1)Quantity Of Spacer : A2-1隔板 X 7 , B2-1隔板 X 3

(2)Total LCM quantity in carton : quantity per box 12 x no of boxes 6 = 72

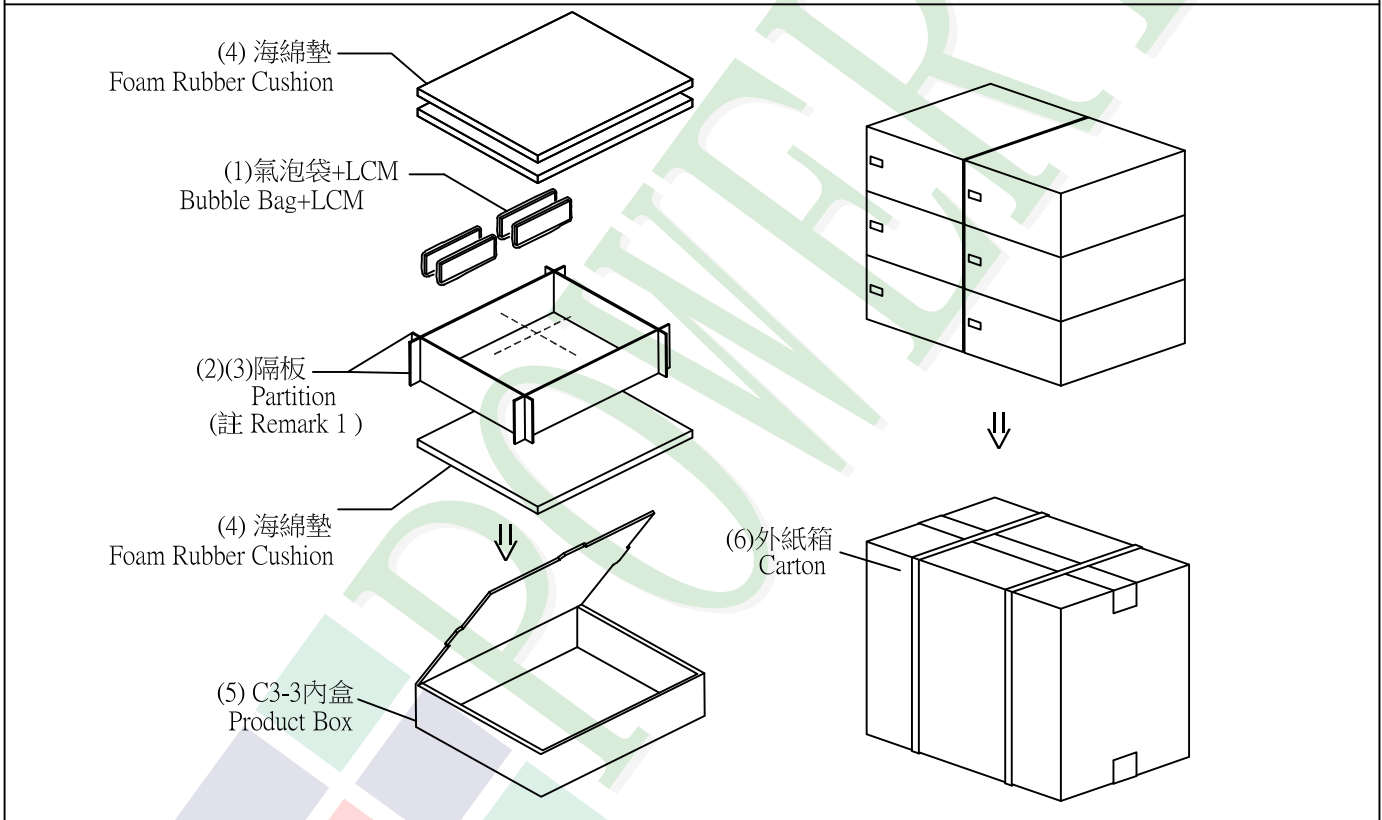

特 記 事 項 (REMARK)

1. LCM排放示意圖(前後間隔不放置):

1. LCM placed as figure showing:
(First and last slot should be empty)

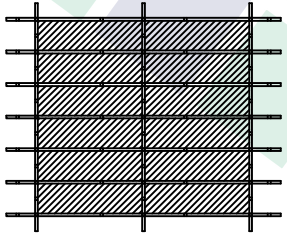

▨ 模組(LCM) X 1pcs.