



SPECIFICATIONS

CUSTOMER	:	_____
SAMPLE CODE	:	SH128800T006-ZFC05
MASS PRODUCTION CODE	:	PH128800T006-ZFC05
SAMPLE VERSION	:	01
SPECIFICATIONS EDITION	:	002
DRAWING NO. (Ver.)	:	LMD-PH128800T006-ZFC05 (Ver.002)
PACKAGING NO. (Ver.)	:	PKG-PH128800T006-ZFC05 (Ver.001)

Customer Approved

Date: _____

Approved	Checked	Designer
廖志豪 Rex Liao	陳宗淇 Howard Chen	張慶源 Yuan Chang

- Preliminary specification for design input
- Specification for sample approval

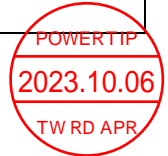

POWERTIP TECH. CORP.

Headquarters: No.8, 6 th Road, Taichung Industrial Park, Taichung, Taiwan 台中市 407 工業區六路 8 號	TEL: 886-4-2355-8168 FAX: 886-4-2355-8166	E-mail: sales@powertip.com.tw Http://www.powertip.com.tw
---	--	--

History of Version

Date	Ver.	Edi.	Description	Page	Design by
06/09/2023	01	001	New Drawing	-	Stephen
10/04/2023	01	002	First Sample Modify Drawing	- Appendix	Yuan

Contents

1. SPECIFICATIONS

- 1.1 Features
- 1.2 Mechanical Specifications
- 1.3 Absolute Maximum Ratings
- 1.4 DC Electrical Characteristics
- 1.5 Optical Characteristics
- 1.6 Backlight Unit Characteristics
- 1.7 Touch Panel Unit Characteristics

2. MODULE STRUCTURE

- 2.1 Counter Drawing
- 2.2 Interface Pin Description
- 2.3 Power Supply Characteristics
- 2.4 HDMI Characteristics

3. QUALITY ASSURANCE SYSTEM

- 3.1 Quality Assurance Flow Chart
- 3.2 Inspection Specification

4. RELIABILITY TEST

- 4.1 Reliability Test Condition

5. PRECAUTION RELATING PRODUCT HANDLING

- 5.1 Safety
- 5.2 Handling
- 5.3 Storage
- 5.4 Terms of Warranty

Appendix :

- 1. LCM Drawing.
- 2. Packaging Specifications

1. SPECIFICATIONS

1.1 Features

<u>Item</u>	<u>Standard Value</u>
Display Resolution	1280 *3 (RGB) * 800 Dots
LCD Type	Full Viewing Angle · Transmissive · Normally Black
Screen Size(inch)	10.1 inch
Color Configuration	16.7M
Touch Driver	FT5726
Weight	520g
Interface	HDMI
ROHS	THIS PRODUCT CONFORMS THE ROHS OF PTC Detail information please refer website: http://www.powertip.com.tw/news_detail.php?Key=1&cID=1

1.2 Mechanical Specifications

<u>Item</u>	<u>Standard Value</u>	<u>Unit</u>
Outline Dimension	254.96(W) * 173.6 (L) * 26.2 (H)	mm

LCD Panel

<u>Item</u>	<u>Standard Value</u>	<u>Unit</u>
Active Area	216.96 (W) * 135.60 (L)	mm

Note : For detailed information please refer to LCM drawing.

1.3 Absolute Maximum Ratings

<u>Item</u>	<u>Symbol</u>	<u>Condition</u>	<u>Min.</u>	<u>Max.</u>	<u>Unit</u>
Power Supply Voltage	VCC	-	-0.3	+18.0	V
Logic Voltage	BL_PWM	-	-0.3	+5.5	V
Operating Temperature	T _{OP} (Ts)	Note 1	-20	+70	°C
Storage Temperature	T _{ST} (Ta)	Note 2	-30	+80	°C
Storage Humidity	H _D	Ta < 60 °C	-	90	%RH

The absolute maximum rating values of this product are not allowed to be exceeded at any times. Should a module be used with any of the absolute maximum ratings exceeded, the characteristics of the module may not be recovered, or in an extreme case, the module may be permanently destroyed.

Note 1 : Ts is the temperature of panel's surface.

Note 2 : Ta is the ambient temperature of samples.

1.4 DC Electrical Characteristics

<u>Item</u>	<u>Symbol</u>	<u>Status</u>	<u>Condition</u>	<u>Min.</u>	<u>Typ.</u>	<u>Max.</u>	<u>Unit</u>
Power Supply Voltage	VCC	I	VCC-GND	11.5	12.0	12.5	V
Power Supply Current	ICC	I	VCC=12.0V	-	0.65	1	A
Logic Voltage	BL_PWM	-	BL_EN=5.0v	0	-	5.0	V
PWM Frequency	FPWM	-	-	100	-	20K	HZ
PWM Duty Ratio	PWM	-	-	5	-	100	%

Note: Maximum current from RGB full-display

1.5 Optical Characteristics

Ta=25°C

Item	Symbol	Condition	Min.	Typ.	Max.	Unit	-
Response Time	Tr + Tf	-	-	25	50	ms	Note2
Viewing Angle	Top	ΘY+	-	85	-	Deg.	Note4
	Bottom	ΘY-	-	85	-		
	Left	ΘX-	-	85	-		
	Right	ΘX+	-	85	-		
Contrast Ratio	CR	-	600	800	-	-	Note3
Color of CIE Coordinate (With B/L)	White	X	0.25	0.30	0.35	-	Note1
		Y	0.28	0.33	0.38		
	Red	X	0.54	0.59	0.64		
		Y	0.30	0.35	0.40		
	Green	X	0.26	0.31	0.36		
		Y	0.53	0.58	0.63		
	Blue	X	0.09	0.14	0.19		
		Y	0.08	0.13	0.18		
Average Brightness Pattern=White Display (With LCD&TP)*1	IV	VCC=12.0V BL_PWM="High"	400	500	-	cd/m2	Note1
Luminance Uniformity (With LCD&TP)*2	YU	Duty=100%	70	-	-	%	Note1

Note1:

1 : $\Delta B = B(\min) / B(\max) \times 100\%$

2 : Measurement Condition for Optical Characteristics:

a : Environment: 25°C±5°C / 60±20%R.H , no wind , dark room below 10 Lux at typical lamp current and typical operating frequency.

b : Measurement Distance: 500 ± 50 mm , (θ= 0°)

c : Equipment: TOPCON BM-7 fast , (field 1°) , after 10 minutes operation.

d : The uncertainty of the C.I.E coordinate measurement ±0.01 , Average Brightness ± 4%

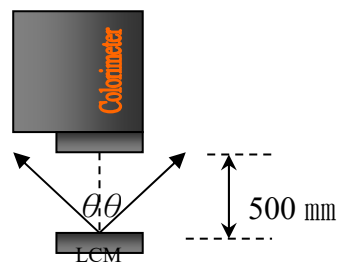
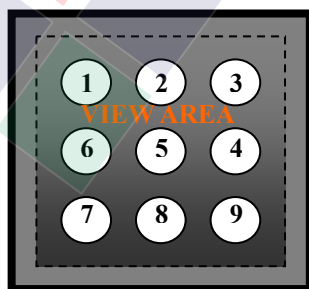

Colorimeter=BM-7 fast

Note2: Definition of response time:

The output signals of photo detector are measured when the input signals are changed from "black" to "white"(falling time) and from "white" to "black"(rising time), respectively. The response time is defined as the time interval between the 10% and 90% of Amplitudes.

Refer to figure as below:

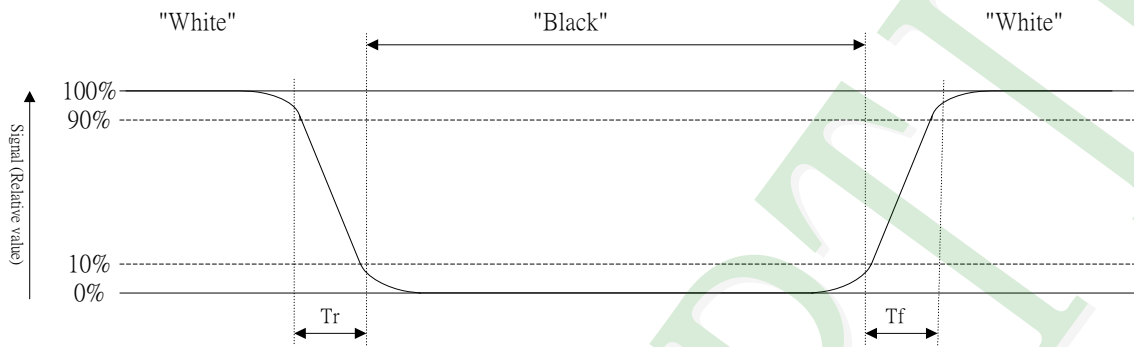

Note3: Definition of contrast ratio:

Contrast ratio is calculated with the following formula

$$\text{Contrast ratio (CR)} = \frac{\text{Photo detector output when LCD is at "White" state}}{\text{Photo detector output when LCD is at "Black" state}}$$

Note4: Definition of viewing angle:

Refer to figure as below:

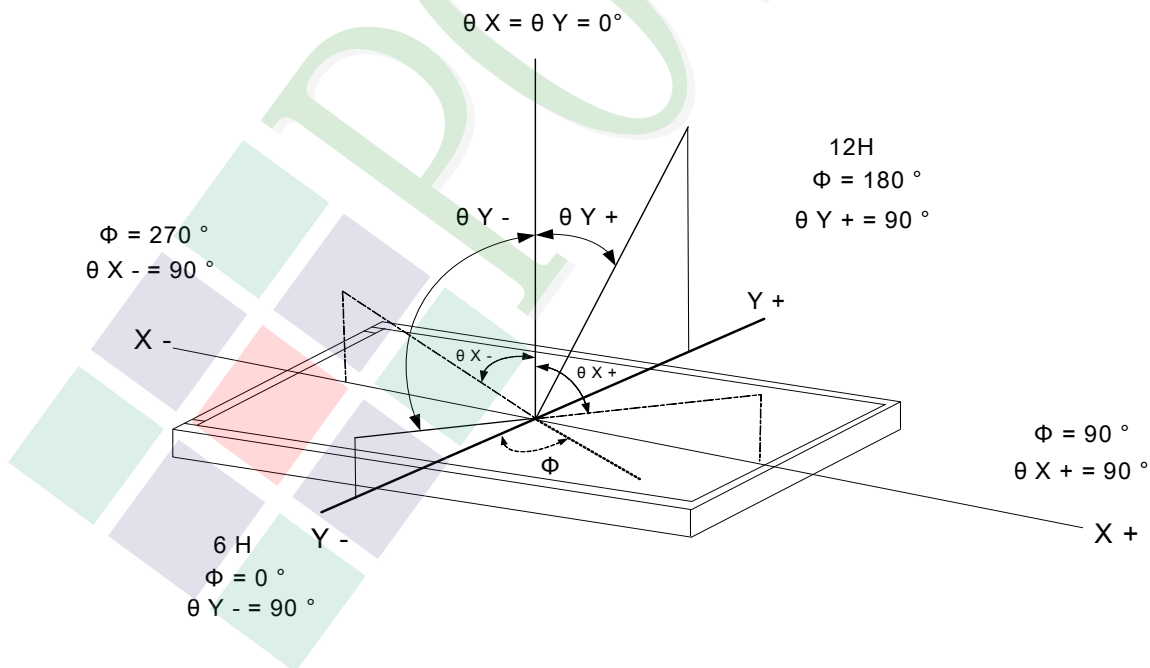

1.6 Backlight Unit Characteristics

Maximum Ratings

Item	Symbol	Conditions	Min.	Typ.	Max.	Unit
Power Dissipation	Pd	-	-	-	100	mW
LED Forward Current	IF	1 LED	-	-	30	mA
LED Reverse Voltage	VR	1 LED	-	-	1.0	V

Electrical / Optical Characteristics

Item	Symbol	Conditions	Min.	Typ.	Max.	Unit
Voltage for LED Backlight	VF	If=80mA	28	30	32	V
Current for LED Backlight	IF		-	80	-	mA
Color	White					

Other Description

Item	Conditions	Description
Life Time	Ta =25°C If= 80 mA	50000 hrs

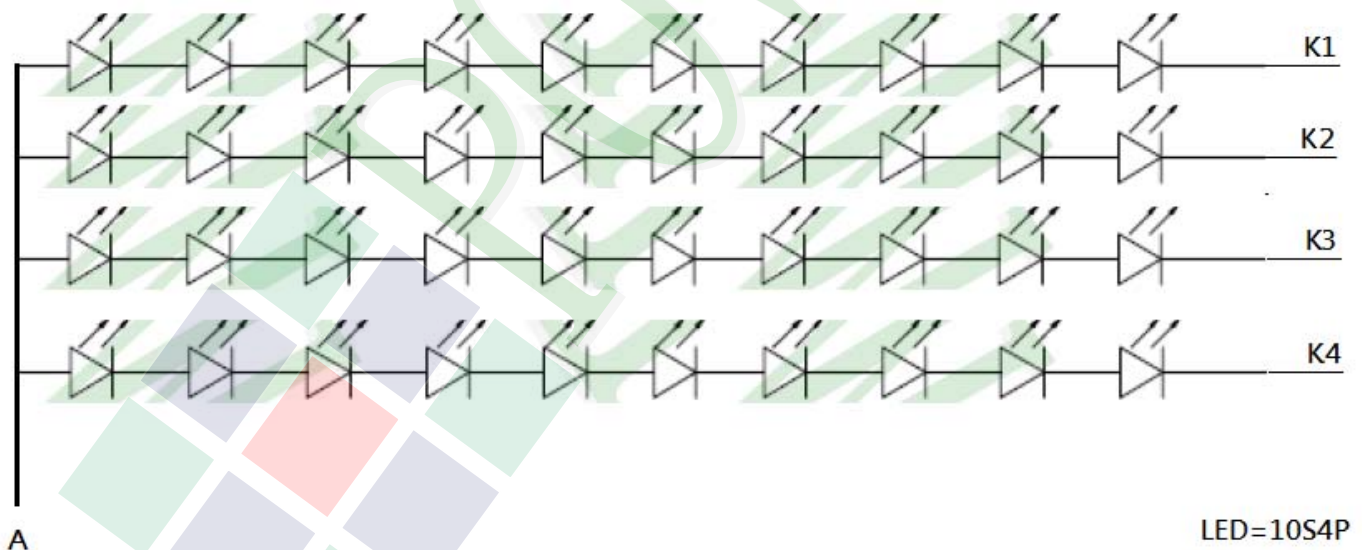

1.7 Touch Panel Characteristics

Features

<u>Item</u>	<u>Standard Value</u>
Touch Panel Size	10.1"
Touch Type	Projective Capacitive Touch Panel
Input Method	Finger
Support Operation	5 Points touch
Output Interface	USB
IC	FT5726

Mechanical Specifications

<u>Item</u>	<u>Standard Value</u>	<u>Unit</u>
Viewing Area	217.96 (W) * 136.60 (L)	mm

Absolute Maximum Ratings

<u>Item</u>	<u>Symbol</u>	<u>Condition</u>	<u>Min.</u>	<u>Max.</u>	<u>Unit</u>
Supply Voltage	VDD_5.0	-	-0.3	+6.0	V
Operating Temperature	T _{OP}	-	-20	+70	°C
Storage Temperature	T _{ST}	-	-30	+80	°C

DC Electrical Characteristics

<u>Item</u>	<u>Symbol</u>	<u>Condition</u>	<u>Min.</u>	<u>Typ.</u>	<u>Max.</u>	<u>Unit</u>
Power Supply Voltage	VDD_5.0	-	-	5.0	-	V

Optical Characteristics

<u>Item</u>	<u>Standard Value</u>	<u>unit</u>
Total Light Transmittance	>85%	-

PCAP Firmware Information

File: ATOAC101D0143 TP_v06_20230920.ini

SHA256: 1FE1DBF9EE773035D0A78FAE7EB88D949466EB1169D5471D2FB779053EE323B0

Remark: None

2. MODULE STRUCTURE

2.1 Counter Drawing

2.1.1 LCM Mechanical Diagram

* See Appendix

2.1.2 Block Diagram

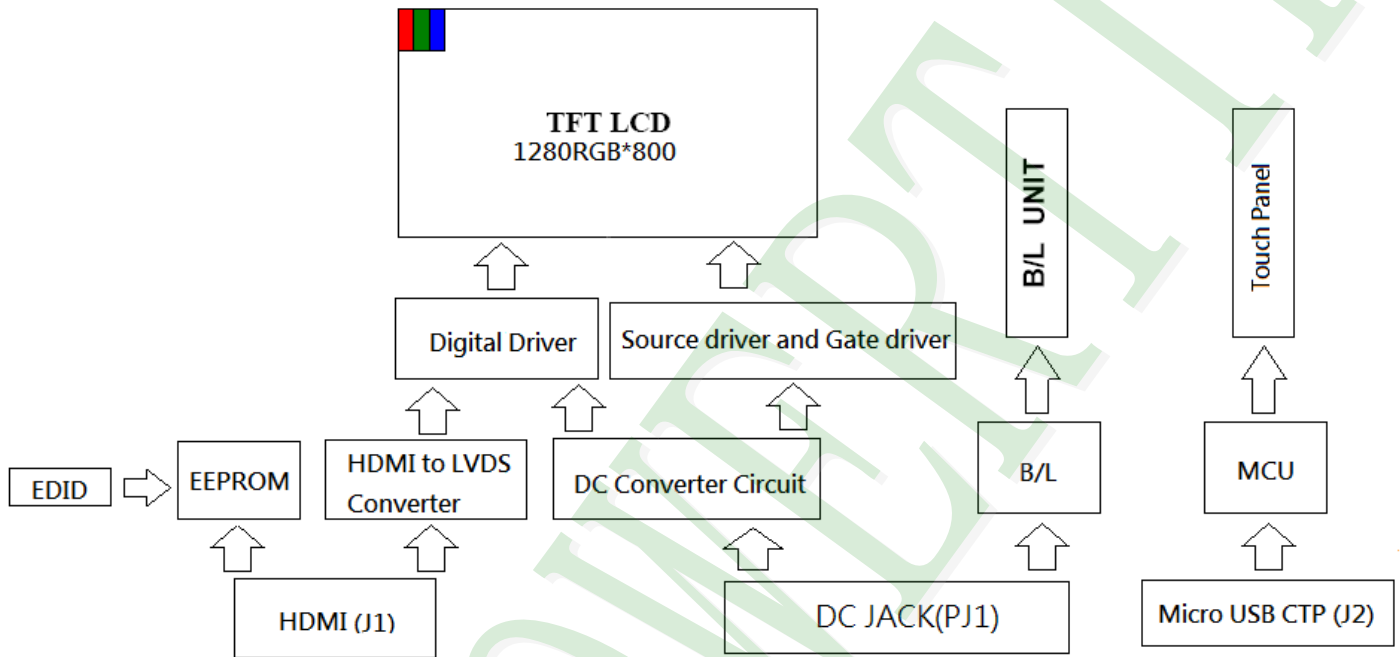

2.2 Interface Pin Description(CN1)

2.2.1 (J1: HDMI 1.3 A type Interface)

Pin#	Name	Description
1	TX2+	TMDS Data 2+
2	TX2 Shield	TMDS Data 2 Shield
3	TX2-	TMDS Data 2-
4	TX1+	TMDS Data 1+
5	TX1 Shield	TMDS Data 1 Shield
6	TX1-	TMDS Data 1-
7	TX0+	TMDS Data 0+
8	TX0 Shield	TMDS Data 0 Shield
9	TX0-	TMDS Data 0-
10	TXC+	TMDS Clock+
11	TXC Shield	TMDS Clock Shield
12	TXC-	TMDS Clock-
13	CEC	CEC
14	NC	No connection
15	SCL	Serial Clock for DDC
16	SDA	Serial Data for DDC
17	GND	Power Ground
18	V5V	+5V Power for HDMI
19	Hot Plug Detect	Hot Plug Detect

2.2.2 (J2: Micro USB Capacitive Touch Panel Interface)

Pin#	Name	Description
1	VBus	VBus 4.75V-5.25V
2	D-	Data-
3	D+	Data+
4	ID	No connection
5	GND	Power Ground.

2.2.3 (PJ1: POWER DC JACK Interface)

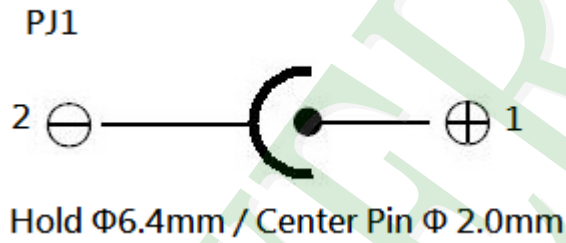

Pin#	Name	Description
1	VCC	+12V Power
2	GND	Power Ground

2.3 Power Supply Characteristics

2.3.1 Power ON/OFF Sequence

- Interface signals are also shown in the chart. Signals from any system shall be Hi-resistance state or low level when VDD voltage is off.

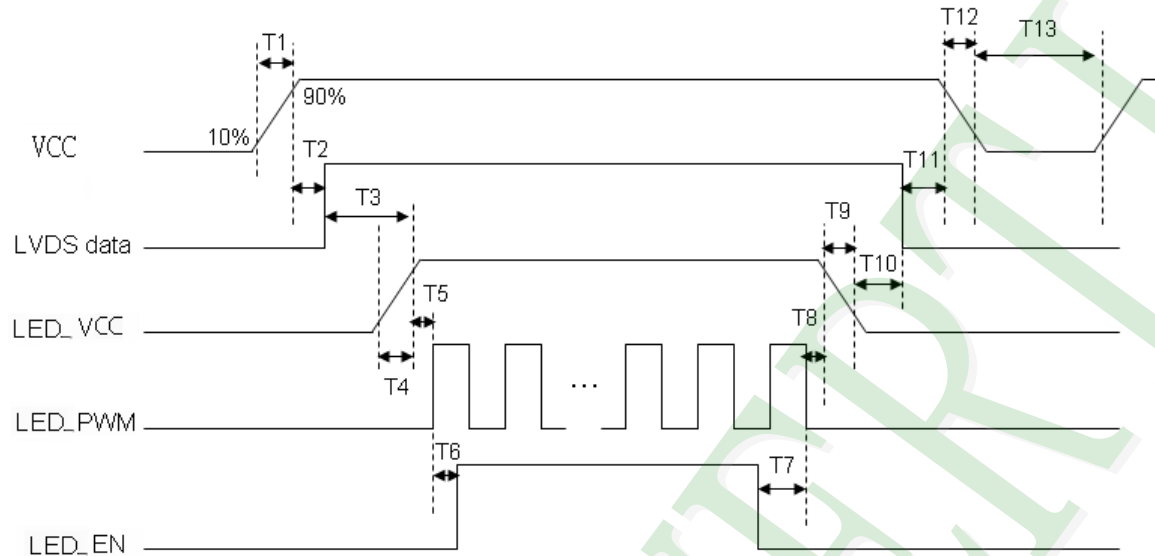

- Please set timing according to the following figures, otherwise it may cause image sticking

Parameter	Symbol	Unit	Min	Typ.	Max
VCC Rise Time (10% to 90%)	T1	ms	0.5	--	10
VCC Good to Signal Valid	T2	ms	30	--	90
Signal Valid to Backlight On	T3	ms	200	--	--
Backlight Power On Time	T4	ms	0.5	--	--
Backlight LED_VCC Good to System PWM On	T5	ms	10	--	--
System PWM On to Backlight LED_EN On	T6	ms	10	--	--
Backlight LED_EN Off to System PWM Off	T7	ms	0	--	--
System PWM Off to B/L Power Disable	T8	ms	10	--	--
Backlight Power Off Time	T9	ms	0.5	10	30
Backlight Off to Signal Disable	T10	ms	200	--	--
Signal Disable to Power Down	T11	ms	0	--	50
VDD Fall Time	T12	ms	0.5	10	30
Power Off	T13	ms	500	--	--

2.3.2 Input Timing

Parameter	Symbol	Min.	Typ.	Max.	Unit
LVDS Clock Frequency	Fclk	70.0	72.4	76.6	MHz
H Total Time	HT	1410	1440	1470	Clocks
H Active Time	HA	1280			
V Total Time	VT	828	838	868	Lines
V Active Time	VA	800			
Frame Rate	FV	-	60	-	Hz

Note1: $HT * VT * \text{Frame Frequency} \leq (76.6) \text{ MHz}$

Note2: All reliabilities are specified for timing specification based on refresh rate of 60Hz.

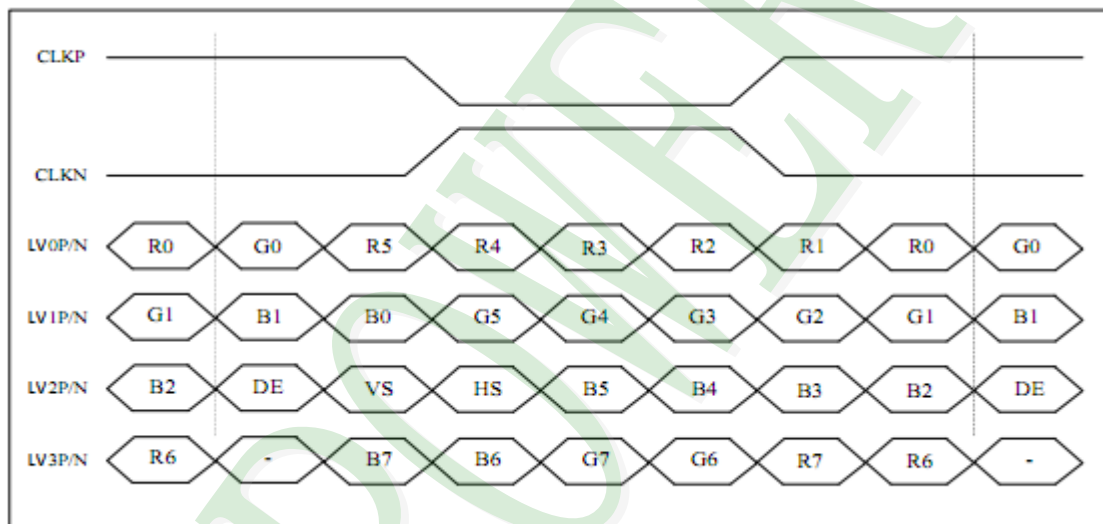

2.3 HDMI Characteristics

2.3.1 DC Electrical Characteristics

over operating free-air temperature range (unless otherwise noted)

Parameter	TEST CONDITIONS	Min	Typ.	Max	Unit
VID Analog input differential voltage(1)	-	75	-	1200	mV
VIC Analog input common-mode voltage(1)	-	AVDD – 300	-	AVDD – 37	mV
VI(OC) Open-circuit analog input voltage	-	AVDD – 10	-	AVDD + 10	mV
IDD(2PIX) Normal 2-pix/clock power supply current	ODCK = 82.5 MHz, 2-pix/clock	-	-	370	mA
IPD Power-down current (3)	PD = low	-	-	10	mA
IPDO Output drive power-down current(3)	PDO = low	35			mA

(1) Specified as dc characteristic with no overshoot or undershoot

(2) Alternating 2-pixel black/2-pixel white pattern. ST = high, STAG = high, QE[23:0] and QO[23:0] CL = 10 pF.

(3) Analog inputs are open circuit (transmitter is disconnected from TFP401/401A).

2.3.2 AC Electrical Characteristics

over recommended operating free-air temperature range (unless otherwise noted)

Parameter	TEST CONDITIONS	Min	Typ.	Max	Unit
VID(2) Differential input sensitivity(1)	-	150	-	1560	mVp-p
tps Analog input intra-pair (+ to –) differential skew(2)	-	-	-	0.4	Tbit (3)
Tccs Analog input inter-pair or channel-to-channel skew (2)	-	-	-	1	Tpix (4)
tjit Worst-case differential input clock jitter tolerance(2) (5)	-	50	-	-	ps
tf1 Fall time of data and control signals(6) (7)	ST = low, CL = 5 pF	-	-	2.4	ns
	ST = high, CL = 10 pF	-	-	1.9	ns
tr1 Rise time of data and control signals(6) (7)	ST = low, CL = 5 pF	-	-	2.4	ns
	ST = high, CL = 10 pF	-	-	1.9	ns
tr2 Rise time of ODCK clock(6)	ST = low, CL = 5 pF	-	-	2.4	ns
	ST = high, CL = 10 pF	-	-	1.9	ns
tf2 Fall time of ODCK clock(6)	ST = low, CL = 5 pF	-	-	2.4	ns
	ST = high, CL = 10 pF	-	-	1.9	ns

(1) Specified as ac parameter to include sensitivity to overshoot, undershoot and reflection.

(2) By characterization

(3) tbit is 1/10 the pixel time, tpix

(4) tpix is the pixel time defined as the period of the RxC input clock. The period of ODCK is equal to tpix in 1-pixel/clock mode or 2tpix when in 2-pixel/clock mode.

(5) Measured differentially at 50% crossing using ODCK output clock as trigger

(6) Rise and fall times measured as time between 20% and 80% of signal amplitude.

(7) Data and control signals are QE[23:0], QO[23:0], DE, HSYNC, VSYNC. and CTL[3:1].

(continued) over recommended operating free-air temperature range (unless otherwise noted)

Parameter	TEST CONDITIONS	Min	Typ.	Max	Unit
tsu1 Setup time, data and control signal to falling edge of ODCK	1.pixel/clock, PIXS = low, OCK_INV =low	1.8	-	-	ns
	2 pixel/clock, PIXS = high, ns STAG = high, OCK_INV = low	3.8	-	-	
	2 pixel and STAG, PIXS = high, STAG= low, OCK_INV = low	0.7	-	-	
th1 Hold time, data and control signal to falling edge of ODCK	1 pixel/clock, PIXS = low, OCK_INV =low	0.6	-	-	ns
	2 pixel and STAG, PIXS = high, STAG = low, OCK_INV = low	2.5	-	-	
	2 pixel/clock, PIXS = high, STAG = high, OCK_INV = low	2.9	-	-	
tsu2 Setup time, data and control signal to rising edge of ODCK	1 pixel/clock, PIXS = low, OCK_INV = high	2.1	-	-	ns
	2 pixel/clock, PIXS = high, ns STAG = high, OCK_INV = high	4	-	-	
	2 pixel and STAG, PIXS = high, STAG = low, OCK_INV = high	1.5	-	-	
th2 Hold time, data and control signal to rising edge of ODCK	1 pixel/clock, PIXS = low, OCK_INV =high	0.5	-	-	ns
	2 pixel and STAG, PIXS = high, STAG = low, OCK_INV = high	2.4	-	-	
	2 pixel/clock, PIXS = high, STAG = high, OCK_INV = high	2.1	-	-	
fODCK ODCK frequency	PIX = low (1-PIX/CLK)	25	-	165	MHz
	PIX = high (2-PIX/CLK)	12.5	-	82.5	
tpd(PDL) Propagation delay time from PD low to Hi-Z outputs	-	40%	50%	60%	-
tpd(PDL) Propagation delay time from PD low to Hi-Z outputs	-	-	-	9	ns

tpd(PDOL) Propagation delay time from PDO low to Hi-Z outputs	-	-	-	9	ns
tt(HSC) Transition time between DE transition to SCDT low(8)	-	-	1e6	-	tpix
tt(FSC) Transition time between DE transition to SCDT high(8)	-	-	1600	-	tpix
td(st) Delay time, ODCK latching edge to QE[23:0] data output	STAG = low, PIXS = high	-	0.25	-	tpix
tWL(PDL_MIN) Minimum time PD is asserted low	-	9	-	-	Ns
tDEL Minimum DE low	-	128	-	-	Tpixel

(8) Link active or inactive is determined by amount of time detected between DE transitions. SCDT indicates link activity.

2.3.3 Parameter Measurement Information

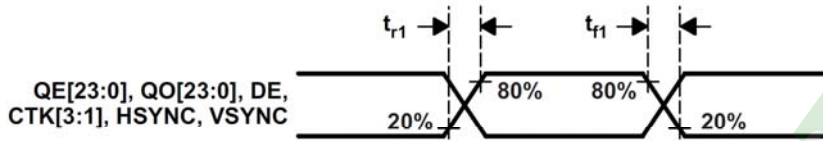
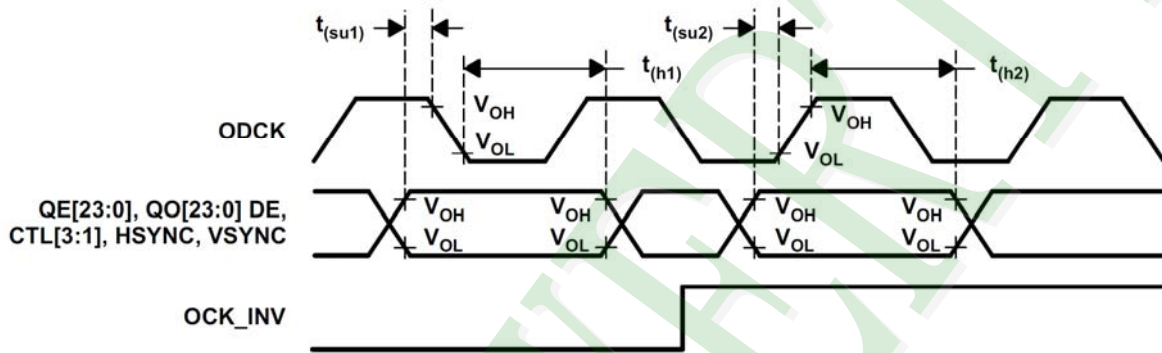
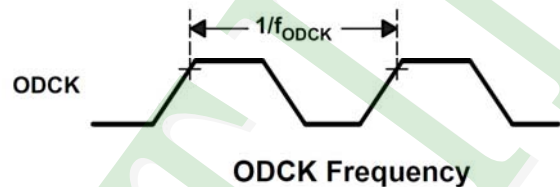
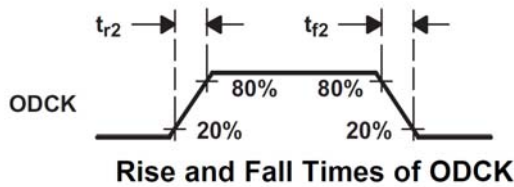
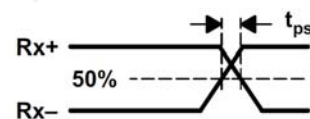
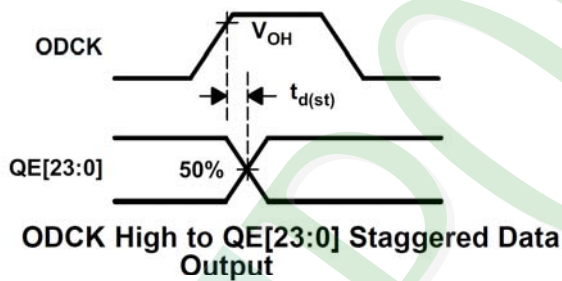

Figure 2. Rise and Fall Times of Data and Control Signals



Data Setup and Hold Times to Rising and Falling Edges of ODCK



Analog Input Intra-Pair Differential Skew

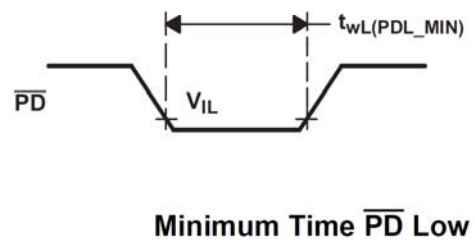
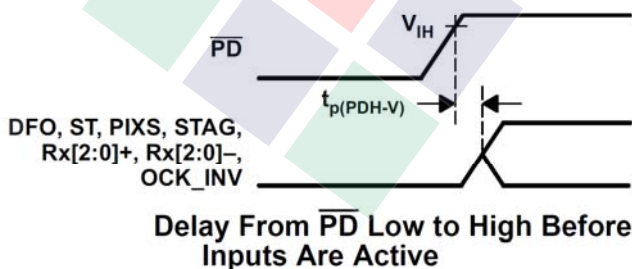
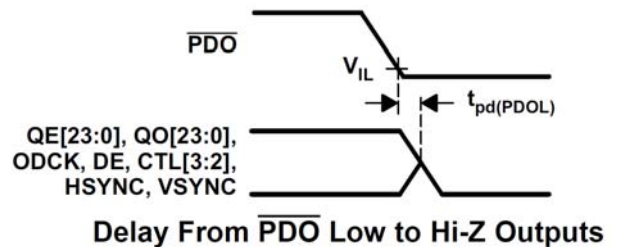
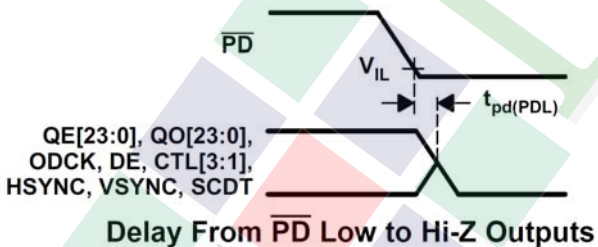

Parameter Measurement Information (continued)

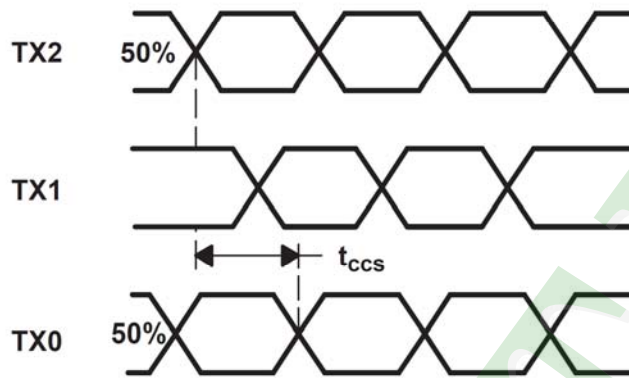

Analog Input Channel-to-Channel Skew

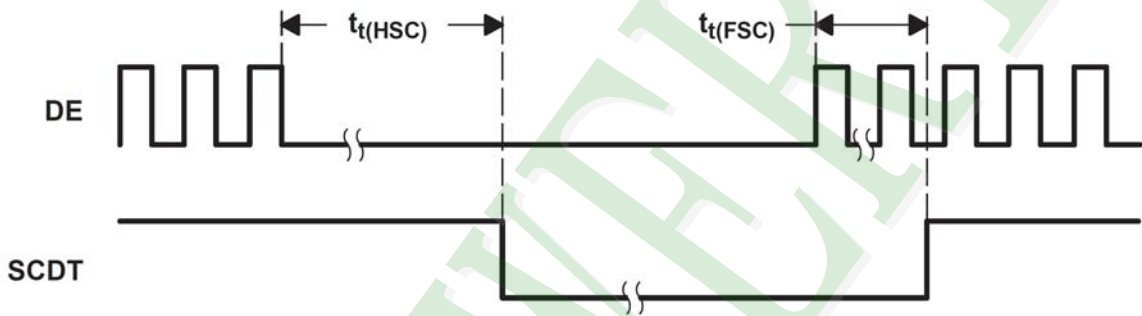

Time Between DE Transitions to SCDT Low and SCDT High

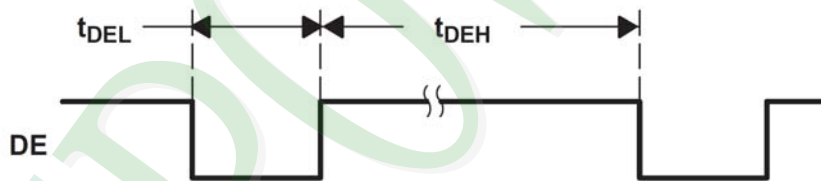

Minimum DE Low and Maximum DE High

3. QUALITY ASSURANCE SYSTEM

3.1 Quality Assurance Flow Chart

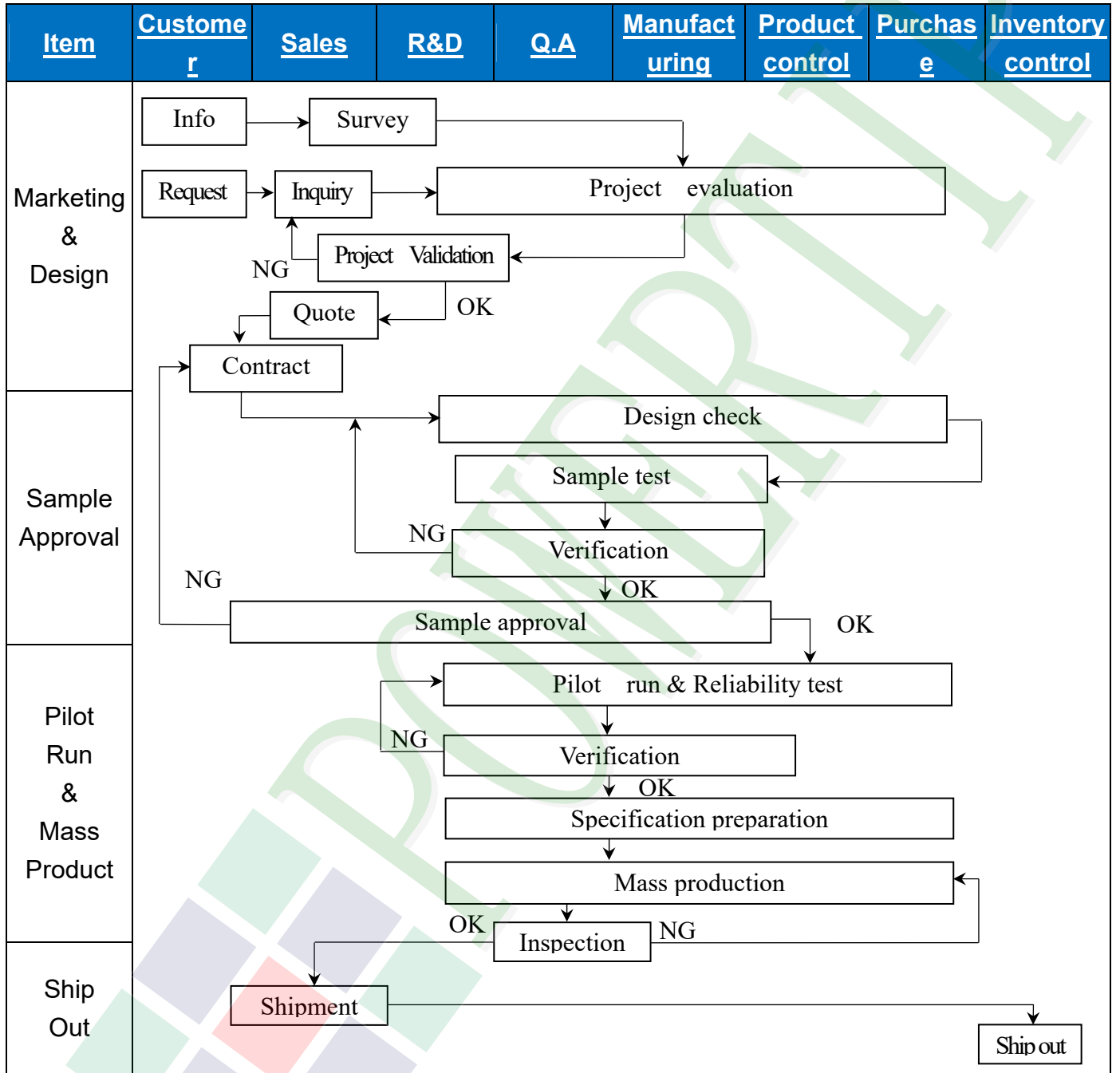

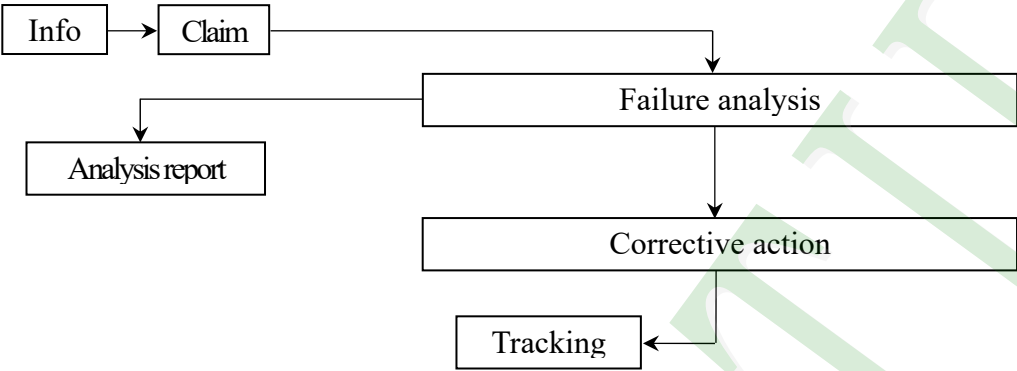
Item	Customer	Sales	R&D	Q.A	Manufacturing	Product control	Purchase	Inventory control
Sales Service	 <pre> graph TD Info[Info] --> Claim[Claim] Claim --> FA[Failure analysis] FA --> AR[Analysis report] FA --> CA[Corrective action] CA --> Tracking[Tracking] </pre>							
Q.A Activity	1. ISO 9001 Maintenance Activities 3. Equipment calibration 5. Standardization Management				2. Process improvement proposal 4. Education And Training Activities			

3.2. Inspection Specification

- ◆ **Scope:** The document shall be applied to TFT-LCD Module for 3.5" -15" (Ver.B01).
- ◆ **Inspection Standard:** MIL-STD-105E Table Normal Inspection Single Sampling Level II.
- ◆ **Equipment:** Gauge, MIL-STD, Powertip Tester, Sample
- ◆ **Defect Level:** Major Defect AQL: 0.4; Minor Defect AQL: 1.5
- ◆ **OUT Going Defect Level:** Sampling.
- ◆ **Standard of the product appearance test:**

a. Manner of appearance test:

- (1). The test best be under 20W×2 fluorescent light(about 300lux ~500lux)
 , and distance of view must be at 30~40 cm.
- (2). The test direction is base on about around 45° of vertical line.

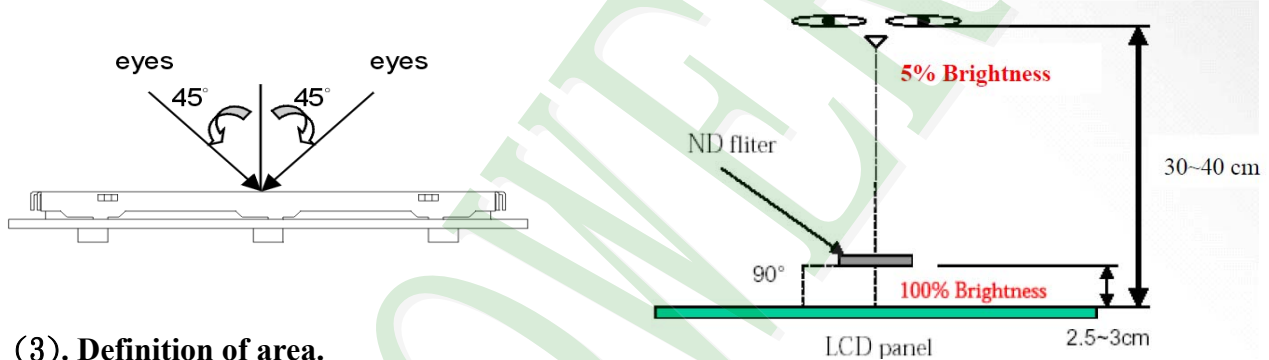

(3). Definition of area.

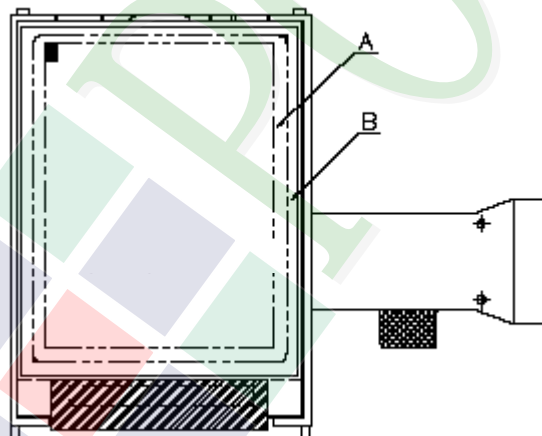

A area: viewing area

B area: Outside of viewing area

(4). Standard of inspection : (Unit : mm)

◆Specification For TFT-LCD Module 3.5” ~15” :

(Ver.B01)

NO	Item	Criterion	Level												
01	Product condition	1. 1The part number is inconsistent with work order of production.	Major												
		1. 2 Mixed product types.	Major												
		1. 3 Assembled in inverse direction.	Major												
02	Quantity	2. 1The quantity is inconsistent with work order of production.	Major												
03	Outline dimension	3. 1Product dimension and structure must conform to structure diagram.	Major												
04	Electrical Testing	4. 1 Missing line character and icon.	Major												
		4. 2 No function or no display.	Major												
		4. 3 Display malfunction.	Major												
		4. 4 LCD viewing angle defect.	Major												
		4. 5 Current consumption exceeds product specifications.	Major												
		4. 6Mura cannot be seen through 5% ND filter at 50% Gray , should be judged by the viewing angle of 90 degree.	Minor												
05	Dot defect (Bright dot, Dark dot) On -display	<table border="1" data-bbox="561 1176 1273 1415"> <thead> <tr> <th></th> <th>Item</th> <th>Acceptance (Q'ty)</th> </tr> </thead> <tbody> <tr> <td rowspan="4">Dot Defect</td> <td>Bright Dot</td> <td>≤ 4</td> </tr> <tr> <td>Dark Dot</td> <td>≤ 5</td> </tr> <tr> <td>Joint Dot</td> <td>≤ 3</td> </tr> <tr> <td>Total</td> <td>≤ 7</td> </tr> </tbody> </table>		Item	Acceptance (Q'ty)	Dot Defect	Bright Dot	≤ 4	Dark Dot	≤ 5	Joint Dot	≤ 3	Total	≤ 7	Minor
			Item	Acceptance (Q'ty)											
Dot Defect	Bright Dot	≤ 4													
	Dark Dot	≤ 5													
	Joint Dot	≤ 3													
	Total	≤ 7													
5.1 Inspection pattern: full white, full black, Red, Green and blue screens. 5.2 It is defined as dot defect if defect area $>1/2$ dot. 5.3 The distance between two dot defect ≥ 5 mm. 5.4 Bright dot : Dots appear bright and unchanged in visible with 5% ND filter is defined. 5.5 Tiny bright dot: bright dot area $\leq 1/2$ dot. a. Dots appear bright and unchanged in visible with 5% ND filter is defined defect and is judged in accordance with 6.1 b. Dots invisible with 5% ND Filter is Ignored.															

◆Specification For TFT-LCD Module 3.5" ~15" :

(Ver.B01)

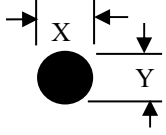
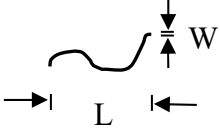
NO	Item	Criterion	Level																																																					
06	<p>Black or white Dot, scratch, contamination</p> <p>Round type</p>  <p>$\Phi = (x+y) / 2$</p> <p>Line type</p> 	<p>6. 1 Round type (Non-display or display):</p> <table border="1" data-bbox="518 403 1311 676"> <thead> <tr> <th rowspan="2">Dimension (diameter: Φ)</th> <th colspan="2">Acceptance (Q'ty)</th> </tr> <tr> <th>A area</th> <th>B area</th> </tr> </thead> <tbody> <tr> <td>$\Phi \leq 0.25$</td> <td colspan="2">Ignore</td> </tr> <tr> <td>$0.25 < \Phi \leq 0.50$</td> <td>5</td> <td rowspan="3">Ignore</td> </tr> <tr> <td>$\Phi > 0.50$</td> <td>0</td> </tr> <tr> <td>Total</td> <td>5</td> </tr> </tbody> </table> <p>6. 2 Line type(Non-display or display):</p> <table border="1" data-bbox="443 795 1390 1332"> <thead> <tr> <th rowspan="2">module size</th> <th rowspan="2">Length (L)</th> <th rowspan="2">Width (W)</th> <th colspan="2">Acceptance (Q'ty)</th> </tr> <tr> <th>A area</th> <th>B area</th> </tr> </thead> <tbody> <tr> <td rowspan="5">3.5" to less 9"</td> <td>---</td> <td>$W \leq 0.03$</td> <td>Ignore</td> <td rowspan="5">Ignore</td> </tr> <tr> <td>$L \leq 10.0$</td> <td>$0.03 < W \leq 0.05$</td> <td>4</td> </tr> <tr> <td>$L \leq 5.0$</td> <td>$0.05 < W \leq 0.10$</td> <td>2</td> </tr> <tr> <td>---</td> <td>$W > 0.10$</td> <td>As round type</td> </tr> <tr> <td colspan="2">Total</td> <td>5</td> </tr> <tr> <td rowspan="4">9" to 15"</td> <td>---</td> <td>$W \leq 0.05$</td> <td>Ignore</td> <td rowspan="4">Ignore</td> </tr> <tr> <td>$L \leq 10.0$</td> <td>$0.05 < W \leq 0.10$</td> <td>5</td> </tr> <tr> <td>---</td> <td>$W > 0.10$</td> <td>As round type</td> </tr> <tr> <td colspan="2">Total</td> <td>5</td> </tr> </tbody> </table>	Dimension (diameter: Φ)	Acceptance (Q'ty)		A area	B area	$\Phi \leq 0.25$	Ignore		$0.25 < \Phi \leq 0.50$	5	Ignore	$\Phi > 0.50$	0	Total	5	module size	Length (L)	Width (W)	Acceptance (Q'ty)		A area	B area	3.5" to less 9"	---	$W \leq 0.03$	Ignore	Ignore	$L \leq 10.0$	$0.03 < W \leq 0.05$	4	$L \leq 5.0$	$0.05 < W \leq 0.10$	2	---	$W > 0.10$	As round type	Total		5	9" to 15"	---	$W \leq 0.05$	Ignore	Ignore	$L \leq 10.0$	$0.05 < W \leq 0.10$	5	---	$W > 0.10$	As round type	Total		5	Minor
Dimension (diameter: Φ)	Acceptance (Q'ty)																																																							
	A area	B area																																																						
$\Phi \leq 0.25$	Ignore																																																							
$0.25 < \Phi \leq 0.50$	5	Ignore																																																						
$\Phi > 0.50$	0																																																							
Total	5																																																							
module size	Length (L)	Width (W)	Acceptance (Q'ty)																																																					
			A area	B area																																																				
3.5" to less 9"	---	$W \leq 0.03$	Ignore	Ignore																																																				
	$L \leq 10.0$	$0.03 < W \leq 0.05$	4																																																					
	$L \leq 5.0$	$0.05 < W \leq 0.10$	2																																																					
	---	$W > 0.10$	As round type																																																					
	Total		5																																																					
9" to 15"	---	$W \leq 0.05$	Ignore	Ignore																																																				
	$L \leq 10.0$	$0.05 < W \leq 0.10$	5																																																					
	---	$W > 0.10$	As round type																																																					
	Total		5																																																					
07	<p>Polarizer Bubble</p>	<table border="1" data-bbox="459 1467 1374 1780"> <thead> <tr> <th rowspan="2">Dimension (diameter: Φ)</th> <th colspan="2">Acceptance (Q'ty)</th> </tr> <tr> <th>A area</th> <th>B area</th> </tr> </thead> <tbody> <tr> <td>$\Phi \leq 0.25$</td> <td colspan="2">Ignore</td> </tr> <tr> <td>$0.25 < \Phi \leq 0.50$</td> <td>4</td> <td rowspan="4">Ignore</td> </tr> <tr> <td>$0.50 < \Phi \leq 0.80$</td> <td>1</td> </tr> <tr> <td>$\Phi > 0.80$</td> <td>0</td> </tr> <tr> <td>Total</td> <td>5</td> </tr> </tbody> </table>	Dimension (diameter: Φ)	Acceptance (Q'ty)		A area	B area	$\Phi \leq 0.25$	Ignore		$0.25 < \Phi \leq 0.50$	4	Ignore	$0.50 < \Phi \leq 0.80$	1	$\Phi > 0.80$	0	Total	5	Minor																																				
Dimension (diameter: Φ)	Acceptance (Q'ty)																																																							
	A area	B area																																																						
$\Phi \leq 0.25$	Ignore																																																							
$0.25 < \Phi \leq 0.50$	4	Ignore																																																						
$0.50 < \Phi \leq 0.80$	1																																																							
$\Phi > 0.80$	0																																																							
Total	5																																																							

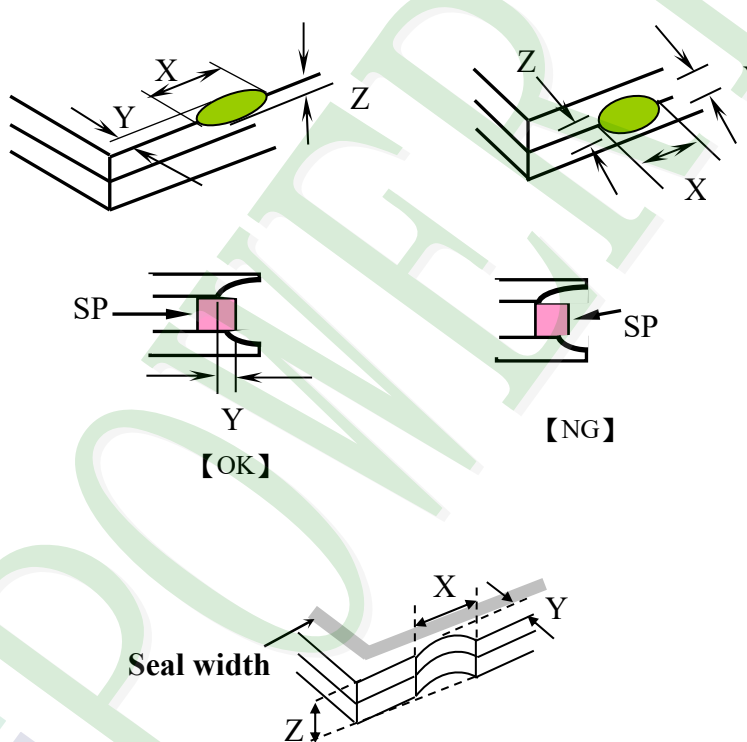
NO	Item	Criterion	Level									
08	The crack of glass	<p>Symbols :</p> <p>X: The length of crack Z: The thickness of crack T: The thickness of glass</p> <p>Y: The width of crack. W: terminal length a : LCD side length</p> <hr/> <p>8.1 General glass chip: 8.1.1 Chip on panel surface and crack between panels:</p>  <table border="1" data-bbox="459 1585 1276 1881"> <thead> <tr> <th><u>X</u></th> <th><u>Y</u></th> <th><u>Z</u></th> </tr> </thead> <tbody> <tr> <td>$\leq a$</td> <td>Crack can't enter viewing area</td> <td>$\leq 1/2 t$</td> </tr> <tr> <td>$\leq a$</td> <td>Crack can't exceed the half of SP width.</td> <td>$1/2 t < Z \leq 2 t$</td> </tr> </tbody> </table>	<u>X</u>	<u>Y</u>	<u>Z</u>	$\leq a$	Crack can't enter viewing area	$\leq 1/2 t$	$\leq a$	Crack can't exceed the half of SP width.	$1/2 t < Z \leq 2 t$	Minor
		<u>X</u>	<u>Y</u>	<u>Z</u>								
$\leq a$	Crack can't enter viewing area	$\leq 1/2 t$										
$\leq a$	Crack can't exceed the half of SP width.	$1/2 t < Z \leq 2 t$										

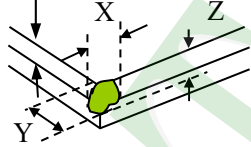
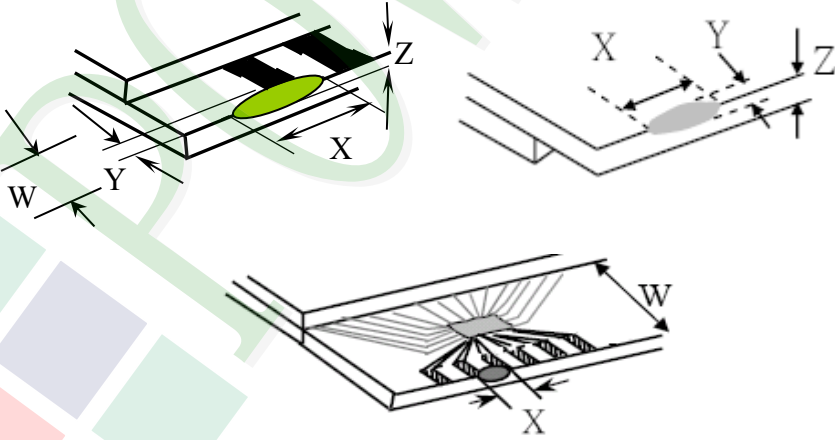
NO	Item	Criterion	Level										
08	The crack of glass	<p>Symbols :</p> <p>X: The length of crack Z: The thickness of crack t: The thickness of glass</p> <p>Y: The width of crack. W: terminal length a: LCD side length</p> <hr/> <p>8.1.2 Corner crack:</p>  <table border="1" data-bbox="461 779 1278 1070"> <thead> <tr> <th><u>X</u></th> <th><u>Y</u></th> <th><u>Z</u></th> </tr> </thead> <tbody> <tr> <td>$\leq 1/5 a$</td> <td>Crack can't enter viewing area</td> <td>$Z \leq 1/2 t$</td> </tr> <tr> <td>$\leq 1/5 a$</td> <td>Crack can't exceed the half of SP width.</td> <td>$1/2 t < Z \leq 2 t$</td> </tr> </tbody> </table>	<u>X</u>	<u>Y</u>	<u>Z</u>	$\leq 1/5 a$	Crack can't enter viewing area	$Z \leq 1/2 t$	$\leq 1/5 a$	Crack can't exceed the half of SP width.	$1/2 t < Z \leq 2 t$		
		<u>X</u>	<u>Y</u>	<u>Z</u>									
$\leq 1/5 a$	Crack can't enter viewing area	$Z \leq 1/2 t$											
$\leq 1/5 a$	Crack can't exceed the half of SP width.	$1/2 t < Z \leq 2 t$											
<p>8.2 Protrusion over terminal:</p> <p>8.2.1 Chip on electrode pad:</p>  <table border="1" data-bbox="499 1711 1287 1883"> <thead> <tr> <th></th> <th><u>X</u></th> <th><u>Y</u></th> <th><u>Z</u></th> </tr> </thead> <tbody> <tr> <td>Front</td> <td>$\leq a$</td> <td>$\leq 1/2 W$</td> <td>$\leq t$</td> </tr> <tr> <td>Back</td> <td>$\leq a$</td> <td>$\leq W$</td> <td>$\leq 1/2 t$</td> </tr> </tbody> </table>		<u>X</u>	<u>Y</u>	<u>Z</u>	Front	$\leq a$	$\leq 1/2 W$	$\leq t$	Back	$\leq a$	$\leq W$	$\leq 1/2 t$	Minor
	<u>X</u>	<u>Y</u>	<u>Z</u>										
Front	$\leq a$	$\leq 1/2 W$	$\leq t$										
Back	$\leq a$	$\leq W$	$\leq 1/2 t$										

NO	Item	Criterion	Level												
08	The crack of glass	<p>Symbols:</p> <p>X: The length of crack Y: The width of crack. Z: The thickness of crack W: terminal length t: The thickness of glass a: LCD side length</p> <hr/> <p>8.2.2 Non-conductive portion:</p> <table border="1" data-bbox="625 974 1259 1099"> <thead> <tr> <th><u>X</u></th> <th><u>Y</u></th> <th><u>Z</u></th> </tr> </thead> <tbody> <tr> <td>$\leq 1/3 a$</td> <td>$\leq W$</td> <td>$\leq t$</td> </tr> </tbody> </table> <p>⊙ If the chipped area touches the ITO terminal, over 2/3 of the ITO must remain and be inspected according to electrode terminal specifications</p> <p>8.2.3 Glass remain:</p> <table border="1" data-bbox="547 1534 1241 1659"> <thead> <tr> <th><u>X</u></th> <th><u>Y</u></th> <th><u>Z</u></th> </tr> </thead> <tbody> <tr> <td>$\leq a$</td> <td>$\leq 1/3 W$</td> <td>$\leq t$</td> </tr> </tbody> </table> <p>8.2.4 Cracking:</p> <p style="text-align: center;">Not Allowed</p>	<u>X</u>	<u>Y</u>	<u>Z</u>	$\leq 1/3 a$	$\leq W$	$\leq t$	<u>X</u>	<u>Y</u>	<u>Z</u>	$\leq a$	$\leq 1/3 W$	$\leq t$	Minor
<u>X</u>	<u>Y</u>	<u>Z</u>													
$\leq 1/3 a$	$\leq W$	$\leq t$													
<u>X</u>	<u>Y</u>	<u>Z</u>													
$\leq a$	$\leq 1/3 W$	$\leq t$													

◆Specification For TFT-LCD Module 3.5" ~15" :

(Ver.B01)

<u>NO</u>	<u>Item</u>	<u>Criterion</u>	<u>Level</u>
09	Backlight elements	9. 1 Backlight can't work normally.	Major
		9. 2 Backlight doesn't light or color is wrong.	Major
		9. 3 Illumination source flickers when lit.	Major
10	General appearance	10. 1 Pin type, quantity, dimension must match type in structure diagram.	Major
		10. 2 No short circuits in components on PCB or FPC.	Major
		10. 3 Parts on PCB or FPC must be: no wrong parts, missing parts or excess parts.	Major
		10. 4 Product packaging must the same as specified on packaging specification sheet.	Minor
		10. 5 The folding and peeled off in polarizer are not acceptable.	Minor
		10. 6 The PCB or FPC between B/L assembled distance(PCB or FPC) is ≤ 1.5 mm.	Minor

4. RELIABILITY TEST

4.1 Reliability Test Condition

(Ver.B01)

NO.	TEST ITEM	TEST CONDITION											
1	High Temperature Storage Test	Keep in $80 \pm 5^{\circ}\text{C}$ 240 hrs											
2	Low Temperature Storage Test	Keep in $-30 \pm 5^{\circ}\text{C}$ 240 hrs											
3	High Temperature / High Humidity Storage Test	Keep in 60°C / 90% R.H duration for 240 hrs (Excluding the polarizer)											
4	Temperature Cycling Storage Test	$ \begin{array}{ccccccc} & -30^{\circ}\text{C} & \rightarrow & +25^{\circ}\text{C} & \rightarrow & 80^{\circ}\text{C} & \rightarrow & +25^{\circ}\text{C} \\ & (30\text{mins}) & & (5\text{mins}) & & (30\text{mins}) & & (5\text{mins}) \\ & \longleftarrow & & & & & & \longrightarrow \\ & & & & & & & 20 \text{ Cycle} \end{array} $											
5	ESD Test	Air Discharge: Apply 2 KV with 5 times Discharge for each polarity +/-	Contact Discharge: Apply 250 V with 5 times discharge for each polarity +/-										
		1. Temperature ambience : $15^{\circ}\text{C} \sim 35^{\circ}\text{C}$ 2. Humidity relative : $30\% \sim 60\%$ 3. Energy Storage Capacitance(Cs+Cd) : $150\text{pF} \pm 10\%$ 4. Discharge Resistance(Rd) : $330\Omega \pm 10\%$ 5. Discharge, mode of operation : Single Discharge (time between successive discharges at least 1 sec) (Tolerance if the output voltage indication : $\pm 5\%$)											
6	Vibration Test (Packaged)	1. Sine wave $10 \sim 55 \text{ Hz}$ frequency (1 min/sweep) 2. The amplitude of vibration : 1.5 mm 3. Each direction (X、Y、Z) duration for 2 Hrs											
7	Drop Test (Packaged)	<table border="1"> <thead> <tr> <th>Packing Weight (Kg)</th> <th>Drop Height (cm)</th> </tr> </thead> <tbody> <tr> <td>0 ~ 45.4</td> <td>122</td> </tr> <tr> <td>45.4 ~ 90.8</td> <td>76</td> </tr> <tr> <td>90.8 ~ 454</td> <td>61</td> </tr> <tr> <td>Over 454</td> <td>46</td> </tr> </tbody> </table>		Packing Weight (Kg)	Drop Height (cm)	0 ~ 45.4	122	45.4 ~ 90.8	76	90.8 ~ 454	61	Over 454	46
		Packing Weight (Kg)	Drop Height (cm)										
0 ~ 45.4	122												
45.4 ~ 90.8	76												
90.8 ~ 454	61												
Over 454	46												
		Drop Direction : ※ 1 corner / 3 edges / 6 sides each 1time											

◎Result Evaluation Criteria :

Under the display quality test conditions with normal operations with normal operation state. Do not change these conditions as such changes may affect practical display function.

(Normal operation state)

Temperature : $+20 \sim 30^{\circ}\text{C}$

Humidity : $50 \sim 70\%$

Atmospheric pressure : $86 \sim 106 \text{ Kpa}$

5. PRECAUTION RELATING PRODUCT HANDLING

5.1 SAFETY

- 5.1.1 If the LCD panel breaks, be careful not to get the liquid crystal to touch your skin.
- 5.1.2 If the liquid crystal touches your skin or clothes, please wash it off immediately by using soap and water.

5.2 HANDLING

- 5.2.1 Avoid any strong mechanical shock which can break the glass.
- 5.2.2 Avoid static electricity which can damage the CMOS LSI—When working with the module, be sure to ground your body and any electrical equipment you may be using.
- 5.2.3 Do not remove the panel or frame from the module.
- 5.2.4 The polarizing plate of the display is very fragile. So, please handle it very carefully, do not touch, push or rub the exposed polarizing with anything harder than an HB pencil lead (glass, tweezers, etc.)
- 5.2.5 Do not wipe the polarizing plate with a dry cloth, as it may easily scratch the surface of plate.
- 5.2.6 Do not touch the display area with bare hands, this will stain the display area.
- 5.2.7 Do not use ketonics solvent & aromatic solvent. Use with a soft cloth soaked with a cleaning naphtha solvent.
- 5.2.8 To control temperature and time of soldering is $320 \pm 10^{\circ}\text{C}$ and 3-5 sec.
- 5.2.9 To avoid liquid (include organic solvent) stained on LCM
- 5.2.10 Caution!(LCM products with Capacitive Touch Panel)
Strong EMI-sources such as switch-mode power supplies (SMPS) can lead to touch malfunction (e.g. ghost-touches).
Therefore, the touch needs to be thoroughly tested inside the target application.
- 5.2.11 CAUTION: Continuously displaying same static image will result in high possibility of image sticking/image burn-in effect due to TFT panel characteristic.
- 5.2.12 Double-sided tape designed to be attach with the customer's mechanical device, please follow up the rules and regulations published by the original manufacturer of double-sided tape for the attachment operation.

5.3 STORAGE

- 5.3.1 Store the panel or module in a dark place where the temperature is $25^{\circ}\text{C} \pm 5^{\circ}\text{C}$ and the humidity is below 65% RH.
- 5.3.2 Do not place the module near organics solvents or corrosive gases.
- 5.3.3 Do not crush, shake, or jolt the module.

5.4 TERMS OF WARRANTY

- 5.4.1 Applicable warrant period The period is within thirteen months since the date of shipping out under normal using and storage conditions.
- 5.4.2 Unaccepted responsibility
This product has been manufactured to your company's specification as a part for use in your company's general electronic products. It is guaranteed to perform according to delivery specifications. For any other use apart from general electronic equipment, we cannot take responsibility if the product is used in nuclear power control equipment, aerospace equipment, fire and security systems or any other applications in which there is a direct risk to human life and where extremely high levels of reliability are required.

A B C D E F G H

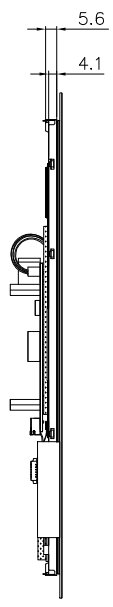
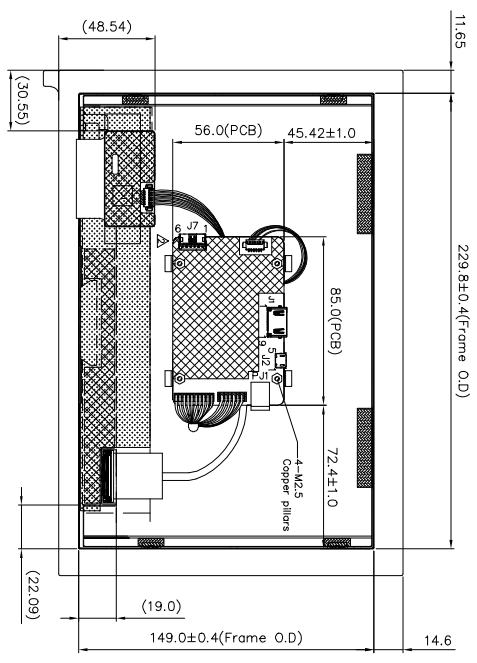
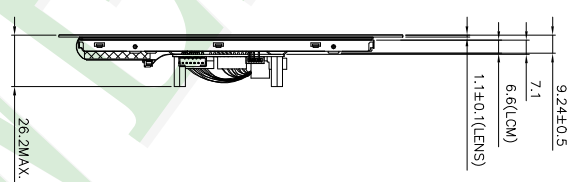
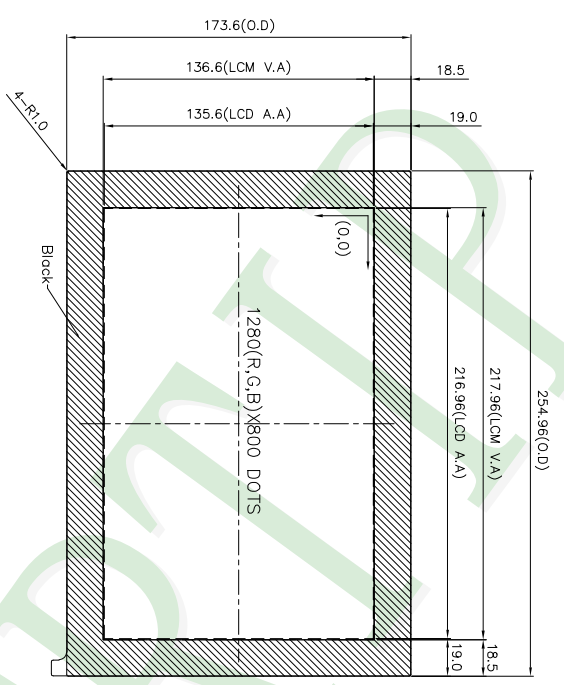

- NOTES:
- 1.LCD TYPE: TFT
 - 2.LCD DISPLAY: Normally Black/Transmissive
 - 3.The tolerance unless classified $\pm 0.3\text{mm}$
 4. Insulating Tape; Shading tape;
 - 5.P.U.I:KD-014-L(DC JACK2.0mm ROHS) OR EQUIVALENT.
 - 6.J1 : FTC-HMAR51610U019S-3440N-7RM4-GP OR EQUIVALENT.
 - 7.J2 : OUPHIN-8971-B05G00DPT OR EQUIVALENT.
 - 8.J7 : JST S6B-PH-KL OR EQUIVALENT.

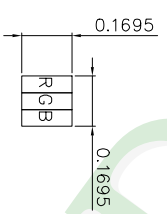

Detail Dots
Scale 150X

007				PART NO:	PH128800T006-ZFC05	久正光电股份有限公司 POWER TIP TECHNOLOGY CORPORATION		Surface Unit MM Scale 1:1 Thickness Quantity		Precision Length (mm) Tolerance Level	
006				DRAWING NAME:	LMD-PH128800T006-ZFC05	Design	Kevin	(3)	1 ~ 4	-	
005				TITLE:	LCD MODULE DRAWING	Check	Stone		4 ~ 16	-	
004				REV BY	Kevin	Approve	Rex		16 ~ 63	-	
003				DATE	2023/8/17				63 ~ 250	-	
002									250 ~ 1000	-	
001											
REV											

Ver.001		Approve	Check	Contact		
Documents NO.	PKG-PH128800T006-ZFC05	Packaging Specifications		Rex	Stone	Kevin

1. (Packaging Material) : (per carton)

No.	Item	Model	Dimensions (mm)	1Pcs Weight	Quantity	Total Weight
1	成品 (LCM)	PH128800T006-ZFC05	254.96 X 173.6	0.516	11	4.12
2	氣泡袋(1)Bubble Bag	BAG0000000048	330X 260	0.01	11	0.08
3	A10隔板(2)A10 Partition	BX00000000119	340 X 174 X 7	0.031	10	0.31
4	B10隔板(3)B10 Partition	BX00000000118	500 X 174 X 7	0.037	2	0.074
5	舒美墊(4)EPE	FOAM000000244	500 X 340 X 20	0.036	2	0.072
6	外箱C6 (5)Carton	BX00000000120	514 X 354 X 228	0.75	1	0.75
7	舒美墊(6)EPE	FOAM000000245	170 X 130 X 15	0.01	4	0.04
8	舒美墊(7)EPE	FOAM000000246	170 X 23 X 15	0.001	49	0.049
9						

2. 一整箱總重量 (Total LCD Weight in carton) : 5.50 Kg±10%

3. 單箱數量規格表 (Packaging Specifications and Quantity) :

- (1)Quantity Of Spacer : A9隔板 X 10 , B9隔板 X 2
- (2)Total LCM quantity in carton : quantity per box 8 x no of boxes 1 = 8

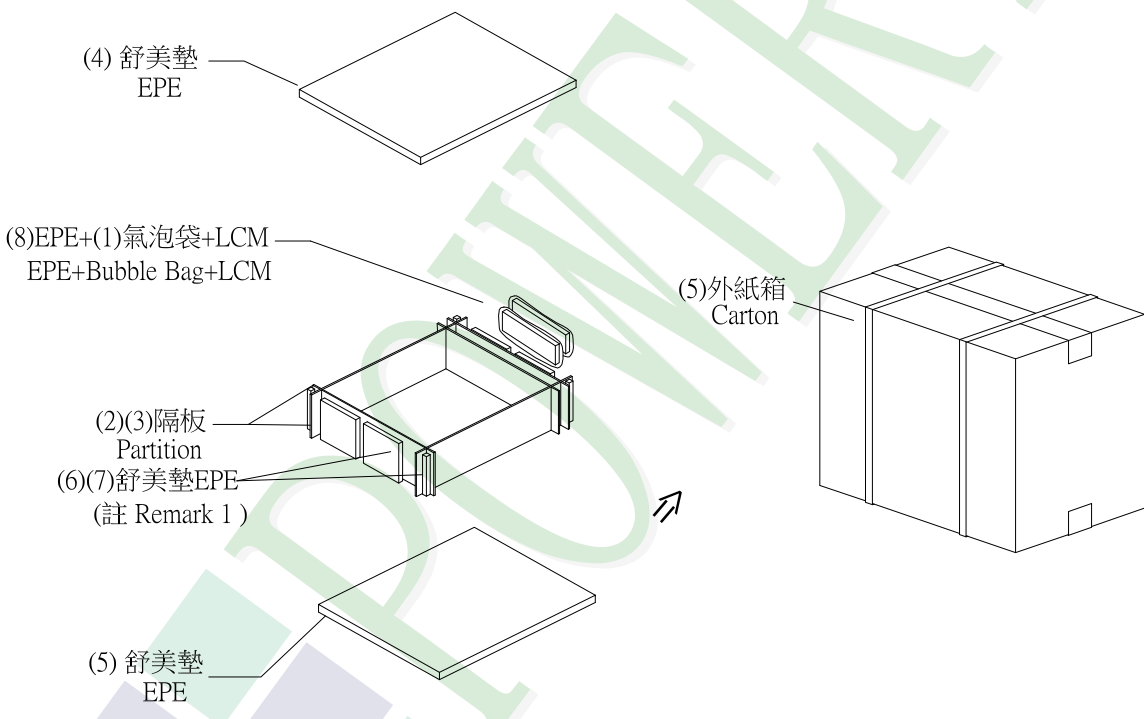

特 記 事 項 (REMARK)

4. LCM排放示意圖(前後間隔不放置):
4. LCM placed as figure showing:
(First and last slot should be empty)

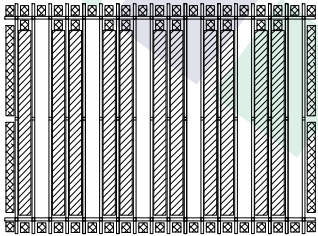

5. 模組銅柱面，朝空的方向擺放，如下示意:

