

TEMPERATURE AND HUMIDITY  
TRANSDUCER SUPPLIED  
FROM A CURRENT LOOP

**P18L**



USER'S MANUAL

**CE**



## Contents

<b>1. Application</b> .....	2
<b>2. Basic requirements, operational safety</b> .....	2
<b>3. Installation</b> .....	2
3.1. Assembly .....	2
3.2. Electrical connections .....	3
<b>4. Servicing</b> .....	4
<b>5. Accessories</b> .....	4
<b>6. Technical data</b> .....	5
<b>7. Before a failure will be declared</b> .....	5
<b>8. Ordering codes</b> .....	6



## 1. Application

The P18L transducer is a device destined for the continuous conversion of relative humidity or ambient temperature into a standard analog current signal. The transducer is fixed on a wall.

Applied sensor shields enable the application of the P18L transducer in various ambient conditions

## 2. Basic requirements, operational safety



In the security scope, the transducer meets the requirements of the EN 61010 -1 standard.

### Remarks concerning the operator safety:

#### 1. General

- All operations concerning transport, installation, and commissioning as well as maintenance must be carried out by qualified, skilled personnel acc. to the section 3.2. of the user's manual.
- According to this basic safety information, qualified, skilled personnel are persons who are familiar with the installation, assembly, commissioning, and operation of the product and who have qualifications necessary for their occupation.
- In order to avoid any damage, before switching the supply on, it is recommended to ensure that all wires were correctly connected. Before the transducer assembly, one must pass supplying wires through the packing. Screw the packing seal in order to obtain the leaktightness. If the packing seal is not screwed, we cannot ensure the required IP65 leaktightness.

When unpacking the P18L transducer, please check whether the type and version code on the data plate correspond to the order code.

## 3. Installation

### 3.1. Assembly

The P18L transducer is designed to be mounted on a wall by means of a screw connection or glue without the loss of IP 65 tightness.

The transducer housing is made of a self-extinguishing plastics.  
Housing dimensions: 64 x 58 x 35 mm.  
The transducer has screw connectors placed inside the transducer, which enable the connection of external wires of 1 mm<sup>2</sup> cross-section.  
Overall dimensions and the fixing way are shown on the fig. 1

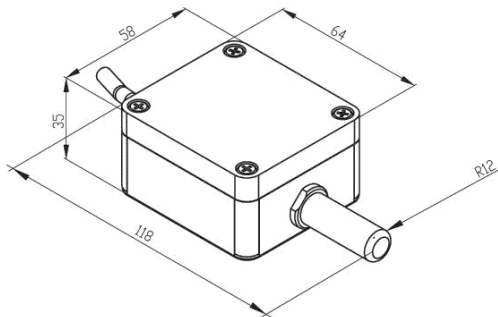

Fig 1. Overall dimensions of the P18L transducer

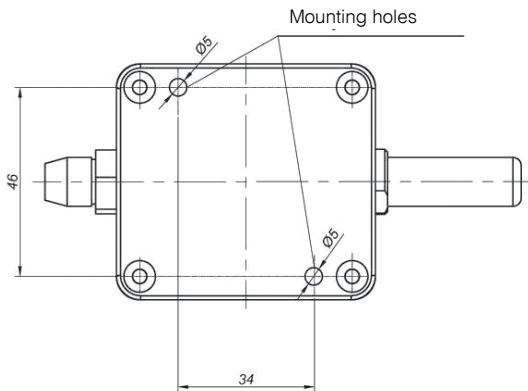

Fig.2. Lay-out of assembly holes of the P18 transducer

### 3.2. Electrical connections

The P18L transducer has 2 connecting terminals to which there is access after removing the cover of the transducer housing.

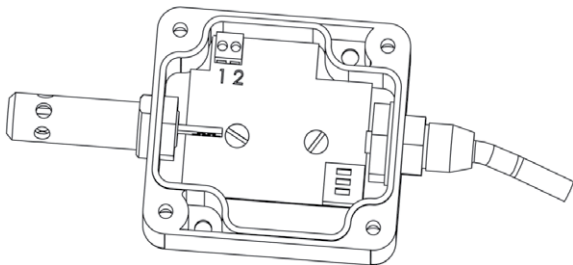

Fig.3 Marking of terminals for the connection of external signals

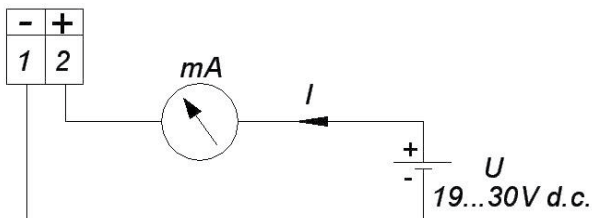

Fig. 4 Way of transducer electrical connections

In case of the transducer work in an environment with high interference, one must apply shielded wires. The shield must be connected to the nearest PE point from the feeder side.

## 4. Servicing

After connecting wires, closing and servicing the housing, and switching to the supply on, the transducer is ready to work.

The correct measurement result appears only after the time of the measurement initialisation ca 2.5 minutes.

After this laps of time, the analog output is correctly steered on.

The transducer converts the temperature or relative humidity into a 4-20 mA standard current signal. The choice of the converted quantity is realized by means of the jumper

Nr 1 of the 3-position switch placed on the transducer plate.

If the jumper Nr 1 is in the position "ON", the transducer converts the relative humidity. (Fig. 5).

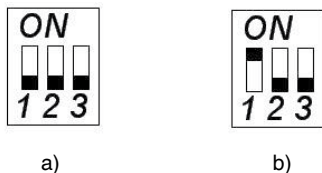



*Fig. 5 Choice of the converted quantity:  
a) temperature,  
b) relative humidity*

## 5. Accessories

As a standard, the P18L transducer is equipped with a metallic shield of the sensor, destined only for indoors application.

For other applications it is recommended to use additional sensor shields, depending on the transducer operation conditions.



Item	Order code	Design	Name	Construction	Features	Typical application
1	<b>20-015-00-00011</b>		Membrane filter	Casing made of PC, Membrane of teflon laminated by a film. Pore size: 1 $\mu\text{m}$	Mean filtration effect. Maximal temp.: up to 80°C Response time: t10/90: 15 s	Building automation. In rooms with low pollution.
2	<b>20-015-00-00007</b>		Filter made of teflon	Sintered teflon. Pore size: 50 $\mu\text{m}$	High chemical resistance. Maximal temp.: up to 180°C Response time: t10/90: 14 s	Drying process in chemical applications
3	<b>20-015-00-00003</b>		Filter made of sintered bronze	Sintered bronze. Pore size: 60 $\mu\text{m}$	High mechanical resistance. To co-operate with high pollution. Applied at small air humidity. Response time: t10/90: 10 s	Agricultural applications

## 6. Technical data

### Basic parameters:

- range of relative humidity measurement (RH)	0...100% without condensation <sup>1)</sup>
- basic error of relative humidity conversion <sup>1)</sup>	± 2% for RH = 10...90% ± 3% for remaining range
- hysteresis of the humidity measurement (T)	± 1% RH
- range of temperature measurement (T)	- 20...60°C
- basic error of temperature conversion	± 0.5% of the range
- additional errors	
- temperature influence	± 25% of the basic error/10°C

### Analog output:

- current	4... 20 mA
- maximal load resistance of the current output	500 Ω

### Rated operating conditions:

- supply	<u>19...30</u> V d.c.
- consumption	< 1.5 VA
- ambient temperature	- 30... <u>23</u> ...85°C
- relative air humidity	< 95% (admissible condensation)
- rate of air flow	2 m/s

---

<sup>1)</sup> In case of water vapour condensation on the sensor surface, the maximal error can increase to 3% RH

- pre-heating time 15 minutes
- protection degree ensured by the housing IP 65
- fixing on a wall
- weight 125 g
- dimensions (35 × 58 × 118) mm
- work position:
  - in applications non-exposed to a direct contact with water any
  - in applications exposed to a direct contact with water with the sensor chamber directed towards the ground.

**Electromagnetic compatibility:**

- immunity noise acc. to EN 61000-6-2
- emission noise acc. to EN 61000-6-4

**Security requirements:**

- installation category acc. to EN 61010-1 III
- pollution grade 2
- working voltage in relation to the earth 50V

**7. Before a failure will be declared**

Possibilities of incorrect work of the P18L transducer Table 2.

Symptoms	Procedure
Data inconsistent with our expectations appear on the transducer output.	In the version with analog outputs, check parameters of the individual characteristic of analog outputs.

## 8. Ordering codes

Ordering codes of P18L transducer versions

Table 3.

	P18L -	XX	X
<b>Version:</b>			
standard		00	
custom-made*		XX	
<b>Acceptance tests:</b>			
without extra quality requirements			8
with an extra quality inspection certificate			7
with calibration certificate			4
according to customer's request*			X

Example of order:

The code: **P18L- 0 0- 8** means

P18L –temperature and humidity transducer.

**1** – current output: 4... 20 mA

**00** – standard version

**8** – without additional quality inspection certificate.

In case of need, one must order additionally the sensor protection shield acc. to the table 1., e.g. the shield coded: 0874-490-014 means a filter made of sintered bronze.

## 9. Maintenance and warranty

The P18L transducer does not require any periodical maintenance. In case of some incorrect operations:

### 1. In the period of 12 months from the date of purchase:

One should take the transducer down from the installation and return it to the Manufacturer Quality Control Dept.

If the unit has been used in compliance with the instructions, the Manufacturer warrants to repair it free of charge.

### 2. After the warranty period:

One should turn over the transducer to repair it in a certified service workshop.

The disassembling of the housing causes the cancellation of the granted warranty.

Spare parts are available for the period of five years from the date of purchase.

Our policy is one of continuous improvement and we reserve the right to make changes in design and specifications of any products as engineering advances or necessity requires and revise the above specifications without notice.







**LUMEL S.A.**

ul. Sulechowska 1, 65-022 Zielona Góra, POLAND  
tel.: +48 68 45 75 100, fax +48 68 45 75 508  
[www.lumel.com.pl](http://www.lumel.com.pl)

**Export department:**

tel.: (+48 68) 45 75 139, 45 75 233, 45 75 321, 45 75 386  
fax.: (+48 68) 32 54 091  
e-mail: [export@lumel.com.pl](mailto:export@lumel.com.pl)