

MDCM0058C0-0016R0TBZ DATASHEET



MODEL	MDCM0058C0-0016R0TBZ
--------------	-----------------------------

Version	Revision of historical records
V2020-1	First Edition
V2020-2	Version Update

FEATURES

- Compact, fully enclosed splash proof design
- Over 1, 000,000 duty cycles
- High power density

APPLICATIONS

- Automotive
- Railway transportation
- Heavy duty machinery
- Energy storage system

SPECIFICATIONS

Electrical	Characteristics
Nominal Capacitance	58 F
Capacitance Tolerance	0% / +20%
Rated Voltage	16 V
Surge Voltage	17 V
ESR,DC	21 mΩ
Maximum Continuous Current (ΔT=15°C)	12 A
Maximum Continuous Current (ΔT=40°C)	20 A
Maximum Peak Current,1sec.	200 A
Leakage Current(25 °C , after 72 h,Excluding equalizing current)	25 mA
Cell	CDCM0350C0-0002R7SPD
Number of Cells	6
Environment	
Operating Temperature Range	-40 °C ~+65 °C
Storage Temperature Range	-40 °C ~+70 °C
Environment Humidity	≤85%RH
Physical	
Weight	0.7 kg
Power Terminals	M5 Thread
Recommended Torque-Terminal	4 Nm
Vibration Specification	IEC 255-21-1
Shock Specification	IEC 255-21-2
Environment Protection	IP54
Monitoring	
Cell Voltage Management	Passive

SPECIFICATIONS

Power And Energy

Usable Power Density (Pd)	2089 W/kg
Impedance Match Power Density(Pmax)	4353 W/kg
Gravimetric Energy Density(Emax)	2.9 Wh/kg
Stored Energy	2.1 Wh

Life

High Temperature Life (at Rated Voltage & Maximum Operating Temperature)	1500 hours
Capacitance Change (%decrease from initial measured value)	≤20%
ESR Change (%increase from specified value)	≤100%
Room Temperature Life (at Rated Voltage at 25°C)	10 years
Capacitance Change (%decrease from initial measured value)	≤20%
ESR Change (%increase from specified value)	≤100%
Cycle Life (Number of cycles)	1,000,000
Capacitance Change (%decrease from initial measured value)	≤20%
ESR Change (%increase from specified value)	≤100%
Shelf Life (25°C, uncharged)	4 years

Safe

Factory High-Pot Test	2500 VDC
-----------------------	----------

NOTES

1. Surge voltage is non-repetitive. The duration must not exceed 1second.
2. Maximum peak current in non-repetitive. The duration must not exceed 1second.
3. Formula of maximum peak current:

$$I_{peak} = \frac{1 / 2CV}{C \times ESR_{DC} + 1}$$

C is rated capacity, V is rated voltage.

4. Formula of power and energy:

Usable Power Density :

$$P_d = \frac{0.12V^2}{ESR_{DC} \times mass}$$

Impedance Match Power Density:

$$P_{max} = \frac{V^2}{4ESR_{DC} \times mass}$$

Gravimetric Energy Density:

$$E_{max} = \frac{1 / 2CV^2}{3600 \times mass}$$

Stored Energy:

$$E = \frac{1 / 2CV^2}{3600}$$

MEASURING METHOD

1) Charge and Discharge procedure (Figure 1)

- a) Charge the capacitor using constant current I to rated voltage V_0 ;
- b) Keep rated voltage 5 min;
- c) Discharge the capacitor using constant current I to half rated voltage, record discharge time T_1 during voltage change from V_1 to V_2 ;
- d) Rest 2-5s, record voltage change ΔV ;
- e) Discharge it to a very low voltage around 0.01V;
- f) $V_1=80\% V_0$ $V_2=50\% V_0$.

2) Capacitance

$$C = I \cdot T_1 / (V_1 - V_2)$$

C: Capacitance(F);

I : Constant Discharge Current(A);

T_1 : Discharge Time(s);

V_1-V_2 : Voltage Change (V).

3) DC ESR

$$DC\ ESR = \Delta V / I$$

DC ESR: DC Equivalent Series Resistance(Ω)

ΔV : Voltage Change(V);

I: Constant Discharge Current (A);

4) AC ESR

Measure AC ESR using LCR meter

Frequency: 1 KHz;

Voltage: fully discharge

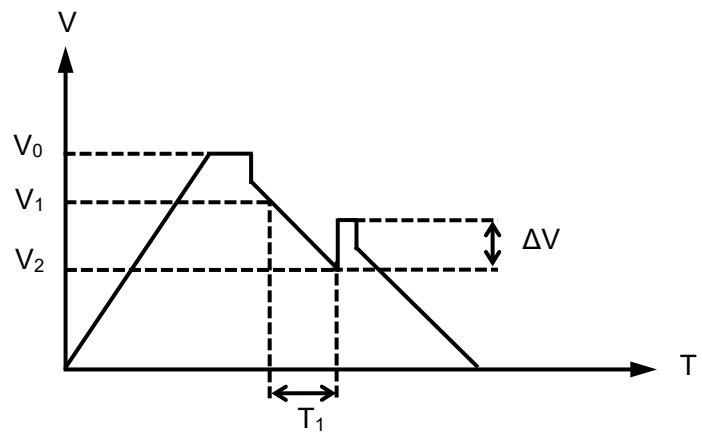
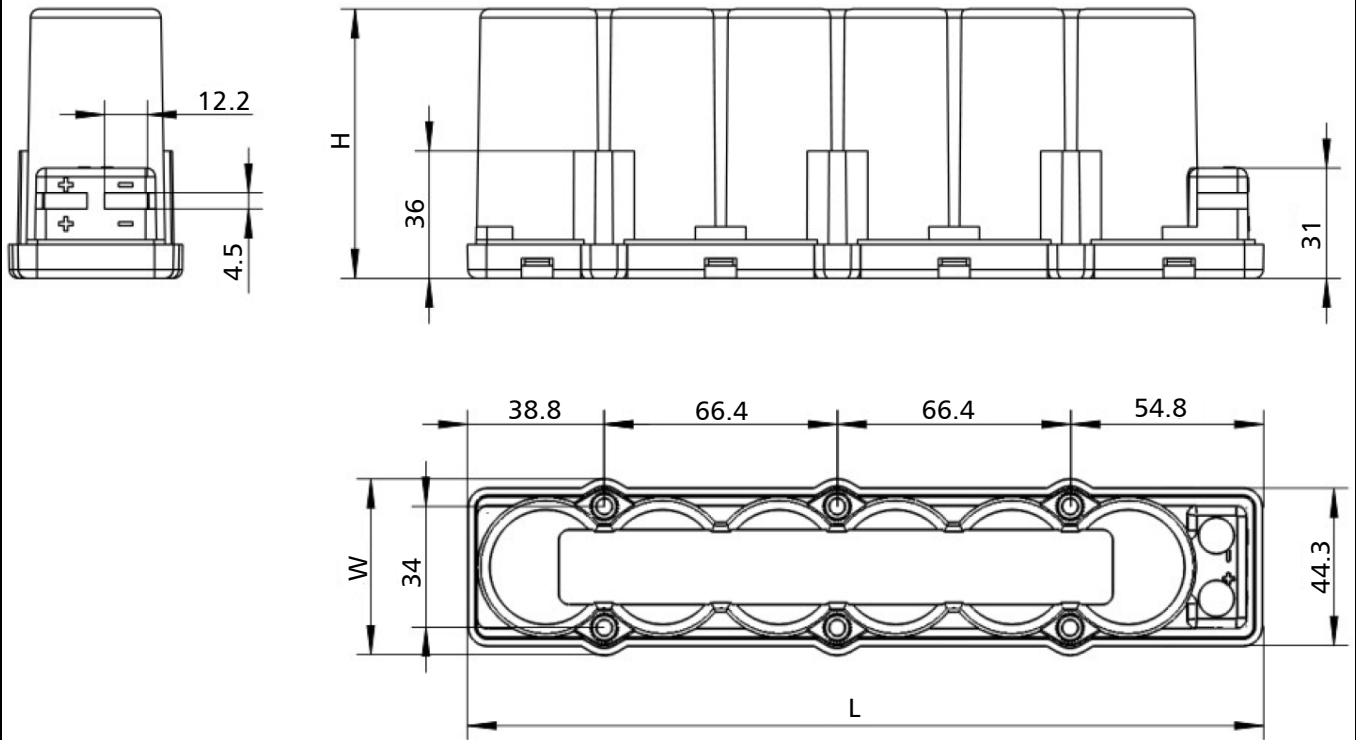

Figure 1

DIMENSIONS



MODEL	Dimension(mm)		
	L(±0.5)	W(±0.5)	H(±0.5)
MDCM0058C0-0016R0TBZ	226.5	49.5	76

All rights reserved. Design and specifications are subjected to change without notice.

NINGBO CRRC NEW ENERGY TECHNOLOGY CO.,LTD.

Add: No.199 Shidai Road,Wuxiang Town,Yinzhou District,
Ningbo,Zhejiang,China

Email: info@spscap.com

Website: www.spscap.com

