



LGE3M40065B

Silicon Carbide Power MOSFET



$V_{DS} = 650\text{ V}$
 $I_D@25^\circ\text{C} = 72\text{ A}$
 $R_{DS(ON)} = 40\text{ m}\Omega$

Features

- High blocking voltage with low on-resistance
- High speed switching with low capacitance
- High operating junction temperature capability
- Very fast and robust intrinsic body diode

Benefits

- Higher System Efficiency
- Parallel Device Convenience without thermal runaway
- High Temperature Application
- Hard Switching & Higher Reliability
- Easy to drive

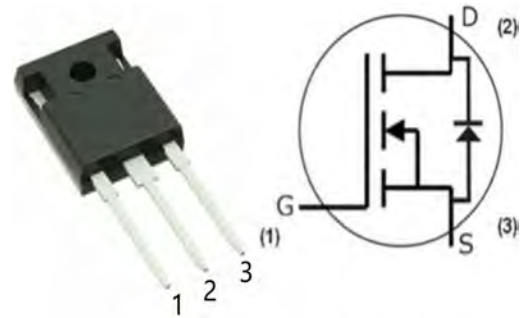

TO-247-3L

Application

- Electric vehicle charging device
- Server and communication power
- Photovoltaic inverter
- UPS power supply
- High voltage DC / DC converter
- Switching Mode Power Suppl

Key performance parameters

Type	V_{DS}	I_D $T_C=25^\circ\text{C}$	$R_{DS(ON)}$
LGE3M40065B	650V	72A	40m Ω

Caution: This device is sensitive to electrostatic discharge .Users should follow ESD handing procedures.



LGE3M40065B

Silicon Carbide Power



Maximum Ratings

$T_C=25^{\circ}\text{C}$, unless otherwise specified

Parameter	Symbol	Value	Unit
Drain-source voltage $V_{GS} = 0\text{V}$, $I_D = 100 \mu\text{A}$	V_{DS}	650	V
Gate-source voltage Recommended maximum	V_{GS}	-5 to 20	V

Maximum Ratings

$T_C=25^{\circ}\text{C}$, unless otherwise specified

Parameter	Symbol	Value	Unit
Continuous drain current : $V_{GS} = 20\text{V}$ $T_C = 25^{\circ}\text{C}$ $T_C = 100^{\circ}\text{C}$	I_D	72 58	A
Pulsed drain current: Pulse width limited by SOA	I_{DM}	180	A
Power dissipation : $T_C = 25^{\circ}\text{C}$	P_{TOT}	348	W
Storage temperature range :	T_{stg}	-55 to +175	$^{\circ}\text{C}$
Operating and junction temperature:	T_j	-55 to +175	$^{\circ}\text{C}$
Soldre temperature: Wave soldering only allowed at leads, 1.6 mm from case for 10 s	T_L	260	$^{\circ}\text{C}$

Thermal Resistance

Parameter	Symbol	Typ.	Unit
Thermal resistance to shell	R_{thJC}	0.431	$^{\circ}\text{C}/\text{W}$

Caution: This device is sensitive to electrostatic discharge .Users should follow ESD handling procedures.



LGE3M40065B

Silicon Carbide Power MOSFET



Electrical Characteristic

$T_C = 25^\circ\text{C}$, unless otherwise specified

Parameter	Symbol	Value			Unit	Test Condition
		Min.	Typ.	Max.		
Zero gate voltage drain current	I_{DSS}		3	100	μA	$V_{DS} = 650\text{V}$ $V_{GS} = 0\text{V}$
Gate leakage current	I_{GSS}		1	± 100	nA	$V_{DS} = 0\text{V}$ $V_{GS} = -5\sim 20\text{V}$
Gate threshold voltage	V_{TH}		3.2 2.2		V	$V_{GS} = V_{DS}$ $I_D = 6.1\text{mA}$ $T_C = 175^\circ\text{C}$
Drain-source on-state resistance	R_{ON}		40 53	55	$\text{m}\Omega$	$V_{GS} = 20\text{V}$ $I_D = 20\text{A}$ $T_J = 25^\circ\text{C}$ $T_J = 175^\circ\text{C}$
Input capacitance	C_{iss}		2692		pF	$V_{DS} = 600\text{V}$ $V_{GS} = 0\text{V}$ $f = 1\text{MHz}$ $V_{AC} = 25\text{mV}$
Output capacitance	C_{oss}		179			
Reverse transfer capacitance	C_{rss}		10.8			
The output capacitor stores energy	E_{oss}		35.6			
Total gate charge	Q_g		110.8		nC	$V_{DS} = 400\text{V}$ $I_D = 20\text{A}$ $V_{GS} = -5\text{ to }20\text{V}$
Gate to source charge	Q_{gs}		26.8			
Gate to drain charge	Q_{gd}		35.7			
Gate input resistance	R_g		2		Ω	$f = 1\text{MHz}$
Turn-on switching energy	E_{ON}		289.1		μJ	$V_{DS} = 400\text{V}$, $I_D = 30\text{A}$, $V_{GS} = -2\text{ to }20\text{V}$, $R_{G(ext)} = 3.3\Omega$, $L = 450\mu\text{H}$
Turn-off switching energy	E_{OFF}		117.1		μJ	
Turn-on delay time	$t_{d(on)}$		24.7		ns	
Rise time	t_r		20.3			

Caution: This device is sensitive to electrostatic discharge .Users should follow ESD handling procedures.



LGE3M40065B

Silicon Carbide Power MOSFET



Turn-off delay time	$t_{d(off)}$		12.4			
Fall time	t_f		29.6			

Reverse Diode Characteristics

$T_c = 25^\circ\text{C}$, unless otherwise specified

Parameter	Symbol	Value			Unit	Test Condition
		Min.	Typ.	Max.		
Diode forward voltage	V_{SD}		4.0 3.6		V	$I_{SD} = 20\text{A}$ $V_{GS} = 0\text{V}$ $T_J = 175^\circ\text{C}$
Reverse recovery time	t_{rr}		23		ns	$V_{GS} = -2\text{V}/+20\text{V}$, $I_{SD} = 30\text{A}$, $V_R = 400\text{V}$, $di/dt = 1700\text{A}/\mu\text{s}$, $R_{G(ext)} = 3.3\ \Omega$ $L = 450\ \mu\text{H}$
Reverse recovery charge	Q_{rr}		161		nC	
Reverse recovery peak current	I_{RRM}		10.4		A	

Caution: This device is sensitive to electrostatic discharge .Users should follow ESD handling procedures.

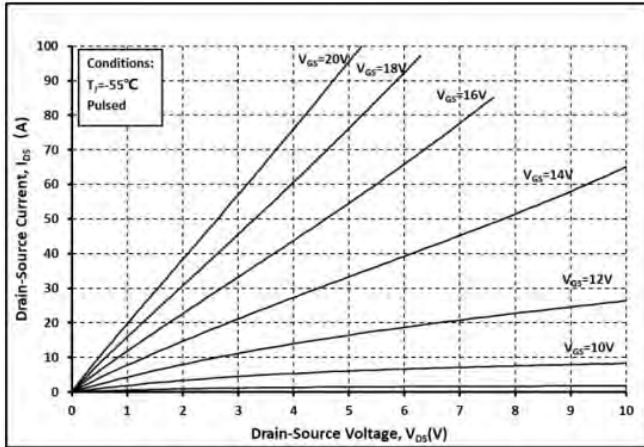
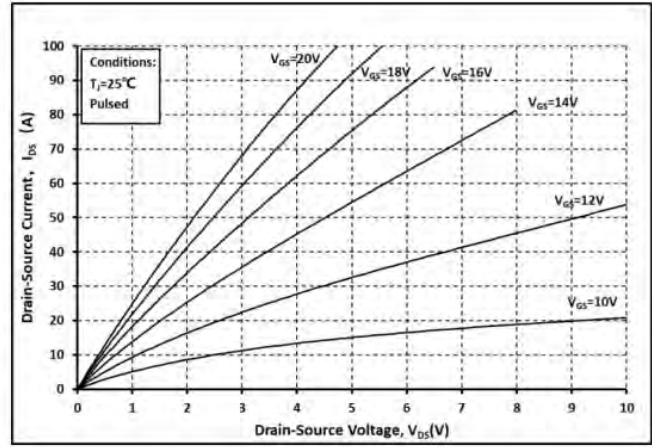
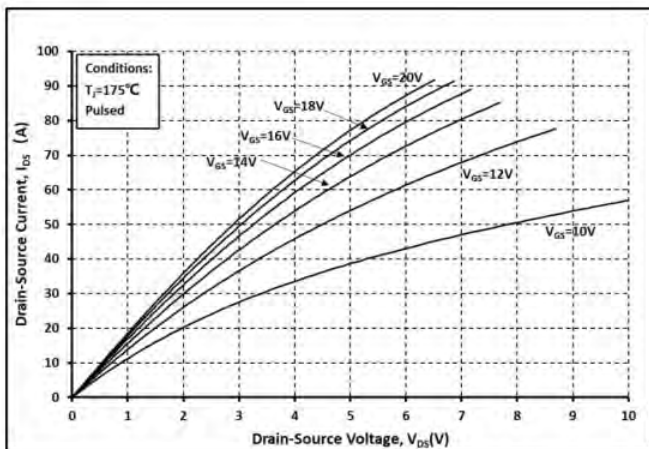
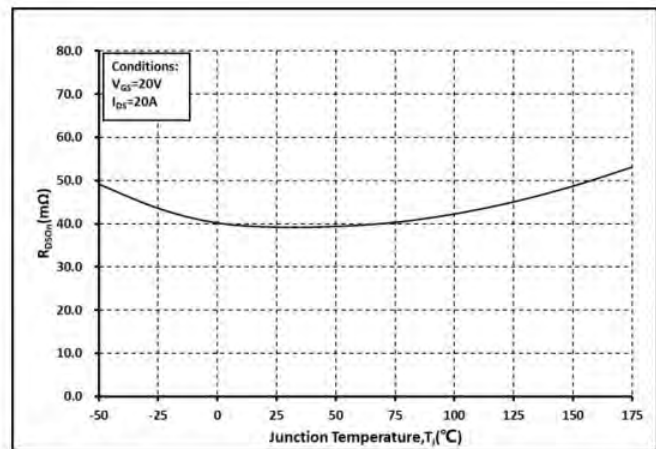
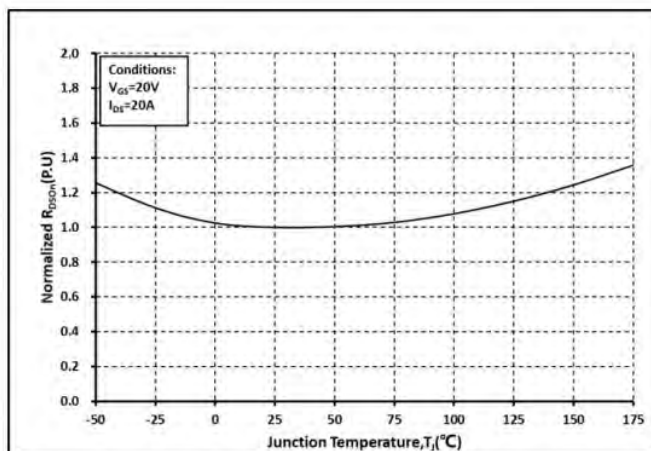
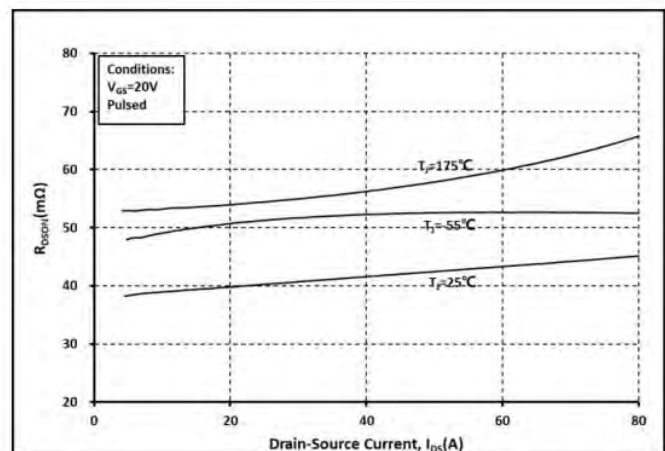
Characteristics Curves

 图. 1 输出曲线 @ $T_j = -55^\circ\text{C}$

 图. 2 输出曲线 @ $T_j = 25^\circ\text{C}$

 图. 3 输出曲线 @ $T_j = 175^\circ\text{C}$

 图. 4 R_{on} 和温度关系曲线

 图. 5 归一化的 R_{on} 和温度关系曲线

 图. 6 各温度下的 R_{on} 和 I_{ds} 关系曲线

Caution: This device is sensitive to electrostatic discharge .Users should follow ESD handling procedures.



图. 7 各 V_{GS} 下的 R_{on} 和温度关系曲线



图. 8 各温度下的传输特性曲线

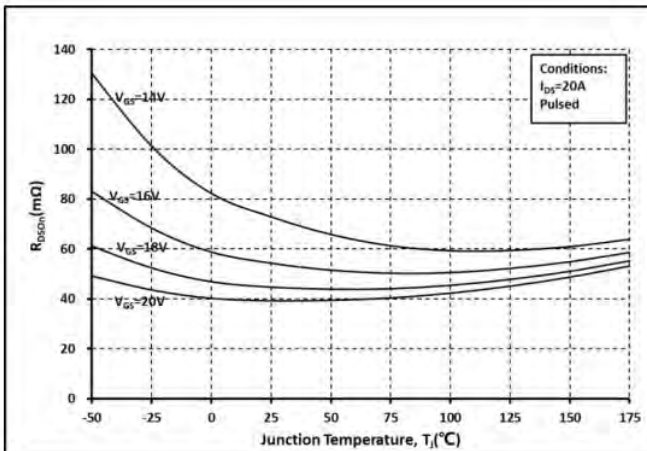

图. 9 阈值电压随温度变化曲线

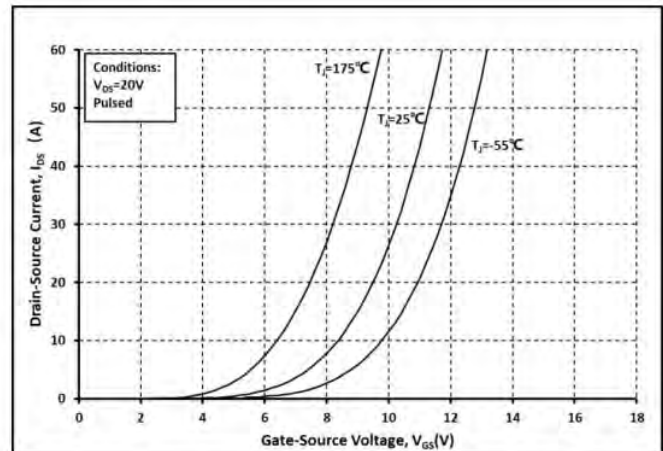

图. 10 体二极管导通曲线 @ $T_j = -55^\circ\text{C}$

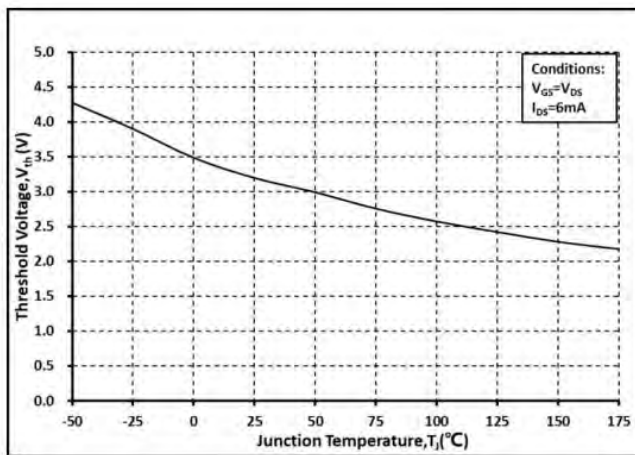

图. 11 体二极管导通曲线 @ $T_j = 25^\circ\text{C}$

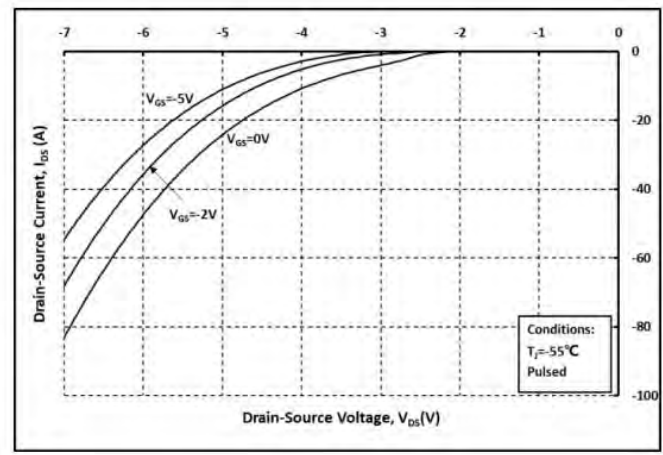

图. 12 体二极管导通曲线 @ $T_j = 175^\circ\text{C}$

Caution: This device is sensitive to electrostatic discharge .Users should follow ESD handling procedures.

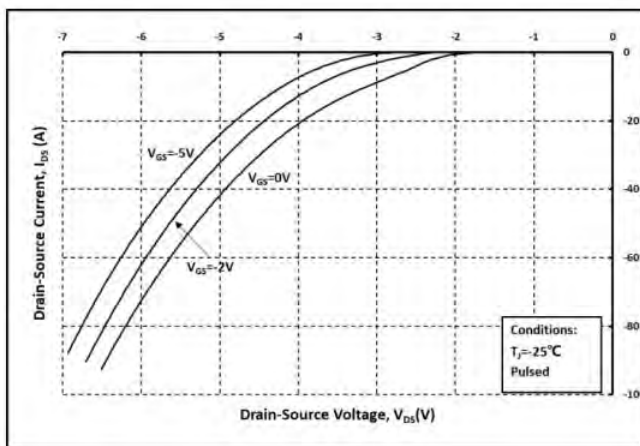

图. 13 第三象限曲线 @ $T_j = -55^\circ\text{C}$

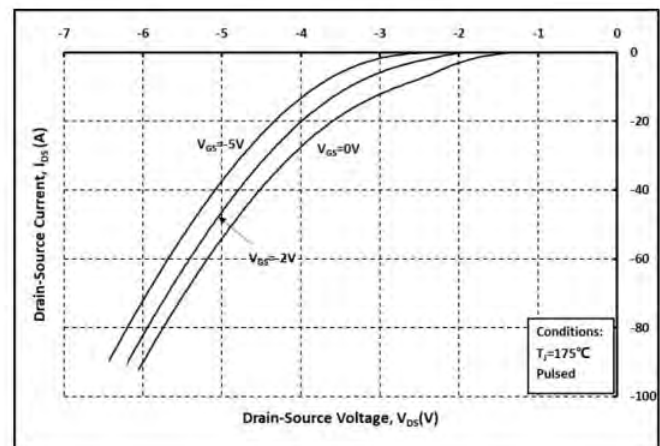

图. 14 第三象限曲线 @ $T_j = 25^\circ\text{C}$

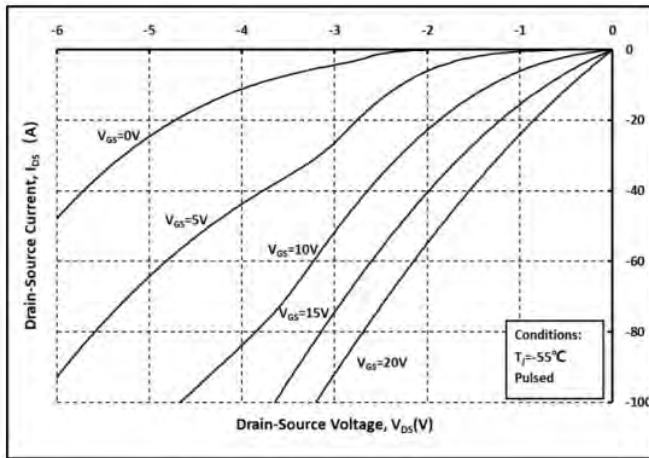

图. 15 第三象限曲线 @ $T_j = 175^\circ\text{C}$

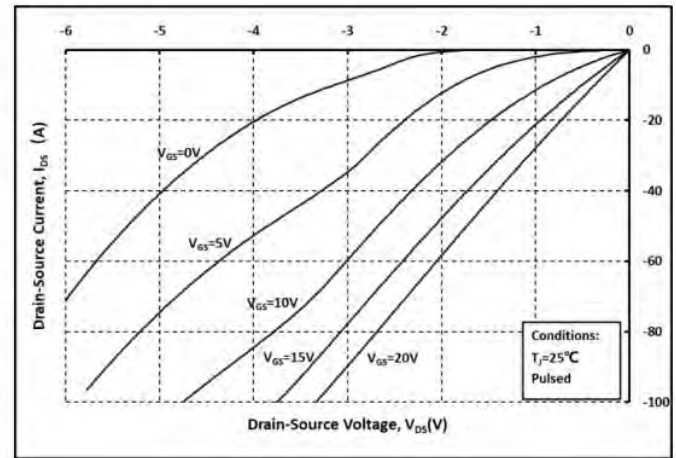

图. 16 各电容和 V_{DS} 关系曲线

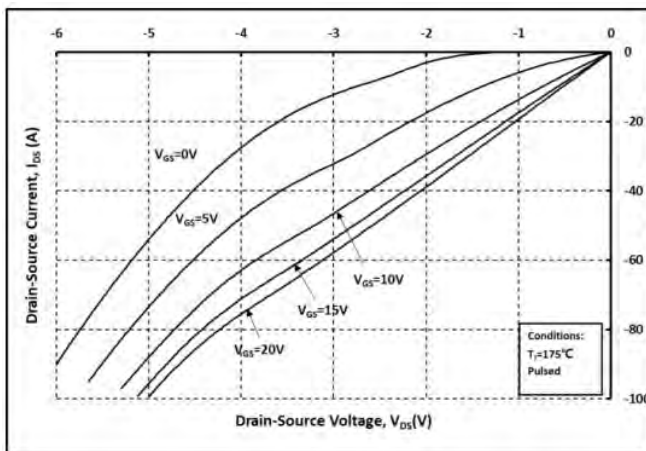

图. 17 输出电容存储能量曲线 c

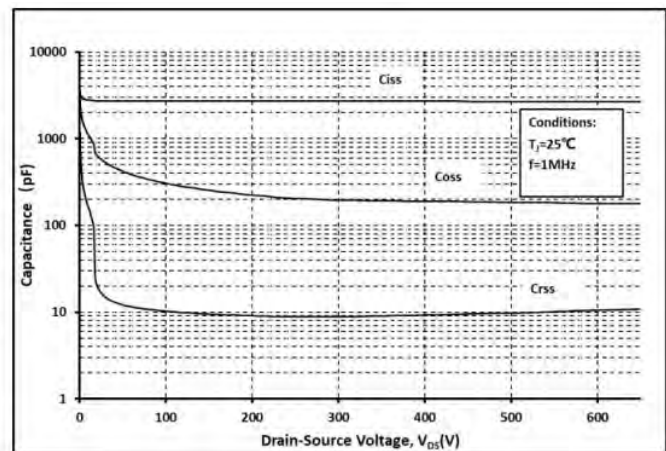

图. 18 栅电荷特征曲线 c

Caution: This device is sensitive to electrostatic discharge .Users should follow ESD handling procedures.

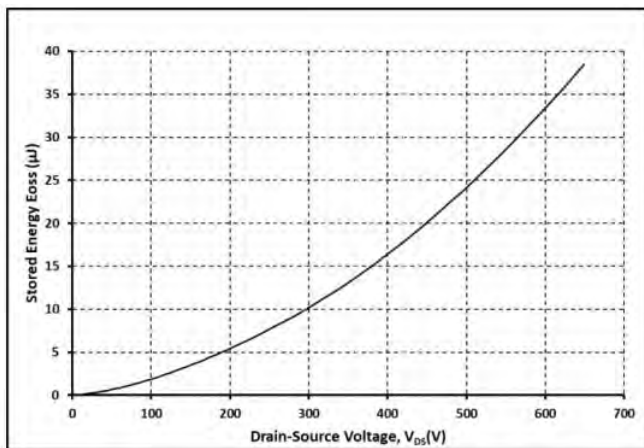

图. 19 开关能量和栅极电阻 $R_{G(ext)}$ 关系曲线

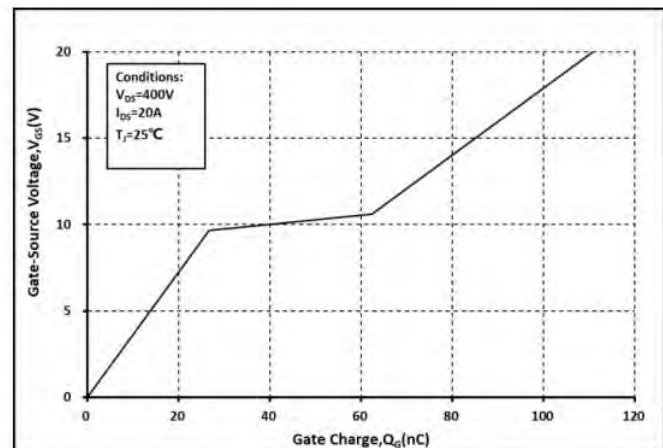

图. 20 开关时间和栅极电阻 $R_{G(ext)}$ 关系曲线

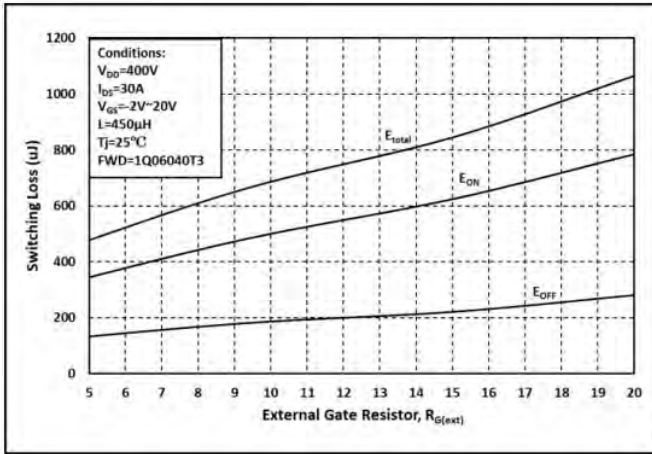

图. 21 漏端电流和温度关系曲线

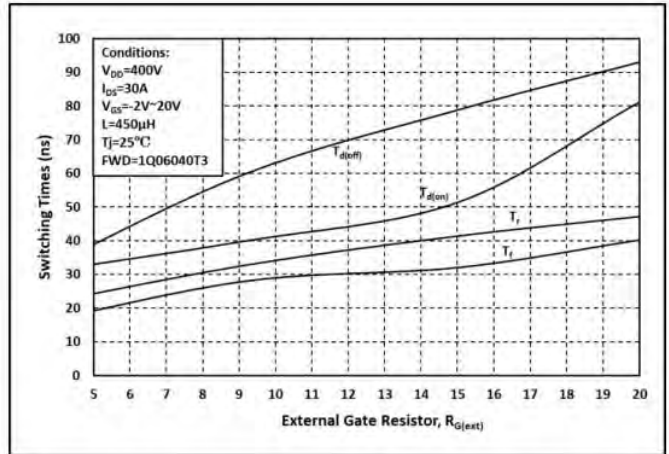

图. 22 最大功耗降额和温度关系曲线

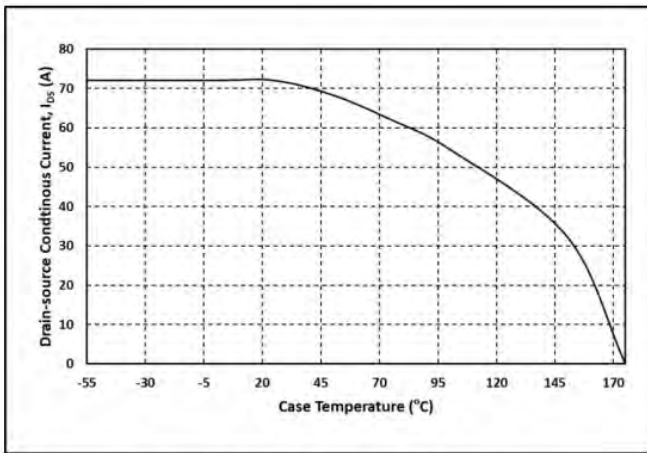

图. 23 热阻曲线

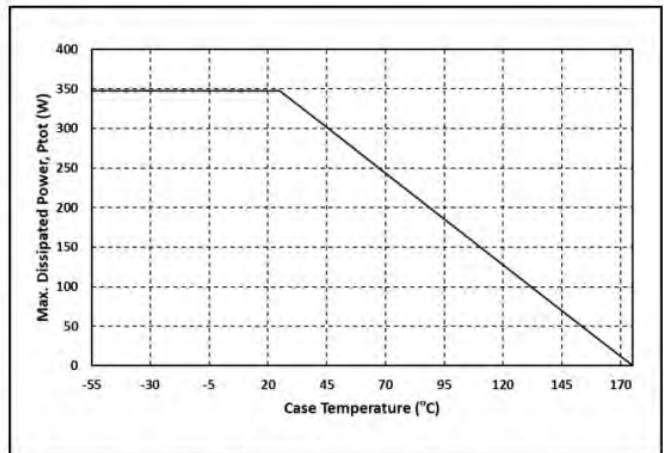

图. 24 安全工作区示意图

Caution: This device is sensitive to electrostatic discharge. Users should follow ESD handling procedures.

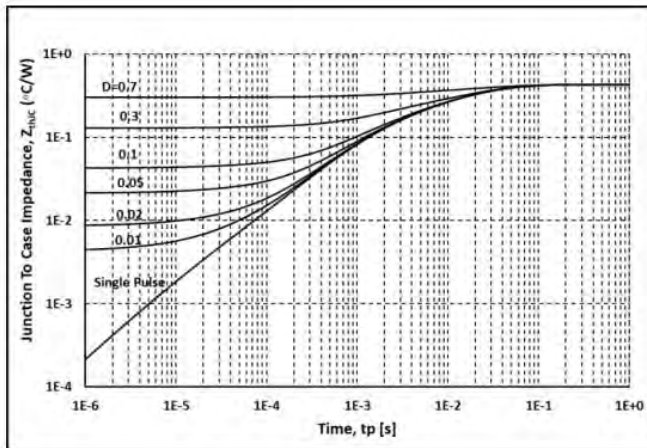

Package Outline: TO-247-3L

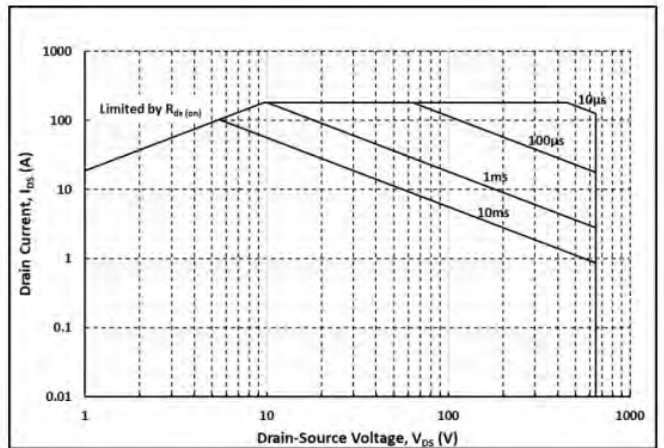
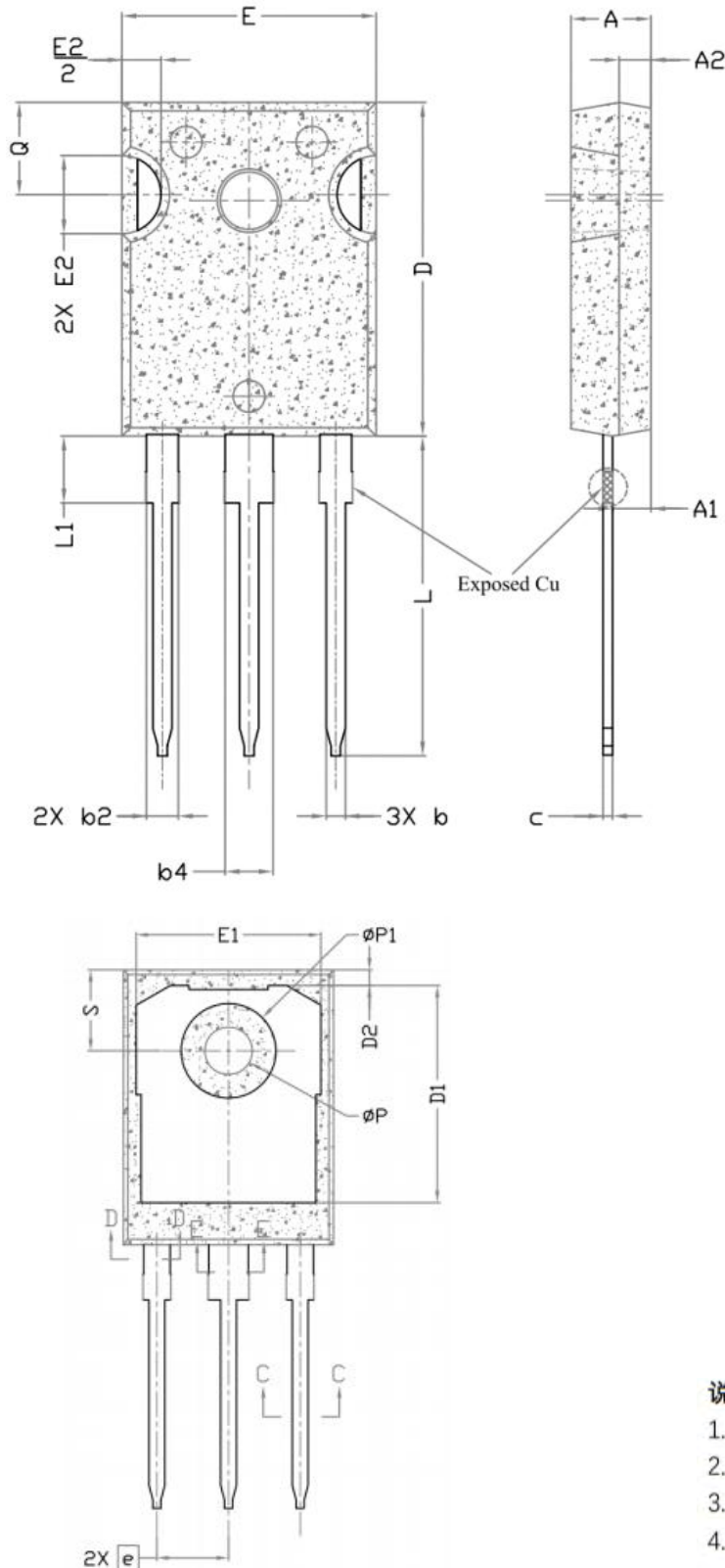

SYMBOL	DIMENSIONS			NOTES
	MIN.	NOM.	MAX.	
A	4.83	5.02	5.21	
A1	2.29	2.41	2.55	
A2	1.50	2.00	2.49	
b	1.12	1.20	1.33	
b1	1.12	1.20	1.28	
b2	1.91	2.00	2.39	6
b3	1.91	2.00	2.34	
b4	2.87	3.00	3.22	6, 8
b5	2.87	3.00	3.18	
c	0.55	0.60	0.69	6
c1	0.55	0.60	0.65	
D	20.80	20.95	21.10	4
D1	16.25	16.55	17.65	5
D2	0.51	1.19	1.35	
E	15.75	15.94	16.13	4
E1	13.46	14.02	14.16	5
E2	4.32	4.91	5.49	3
e	5.44BSC			
L	19.81	20.07	20.32	
L1	4.10	4.19	4.40	6
∅P	3.56	3.61	3.65	7
∅P1	7.19REF.			
Q	5.39	5.79	6.20	
S	6.04	6.17	6.30	

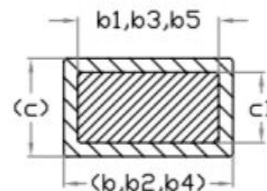

Section C-C, D-D, E-E

说明:

1. 封装标准参考: JEDEC TO247, Variation AD
2. 以上单位为: 毫米
3. 需要开槽, 槽口可为圆形
4. 尺寸 D 和 E 不包括模具溢料

Caution: This device is sensitive to electrostatic discharge .Users should follow ESD handling procedures.