

Magnetic Transducer

SMT15 series



NEW CODE SPECIFICATION

DIMENSIONS

Date : 01 Nov, 2005

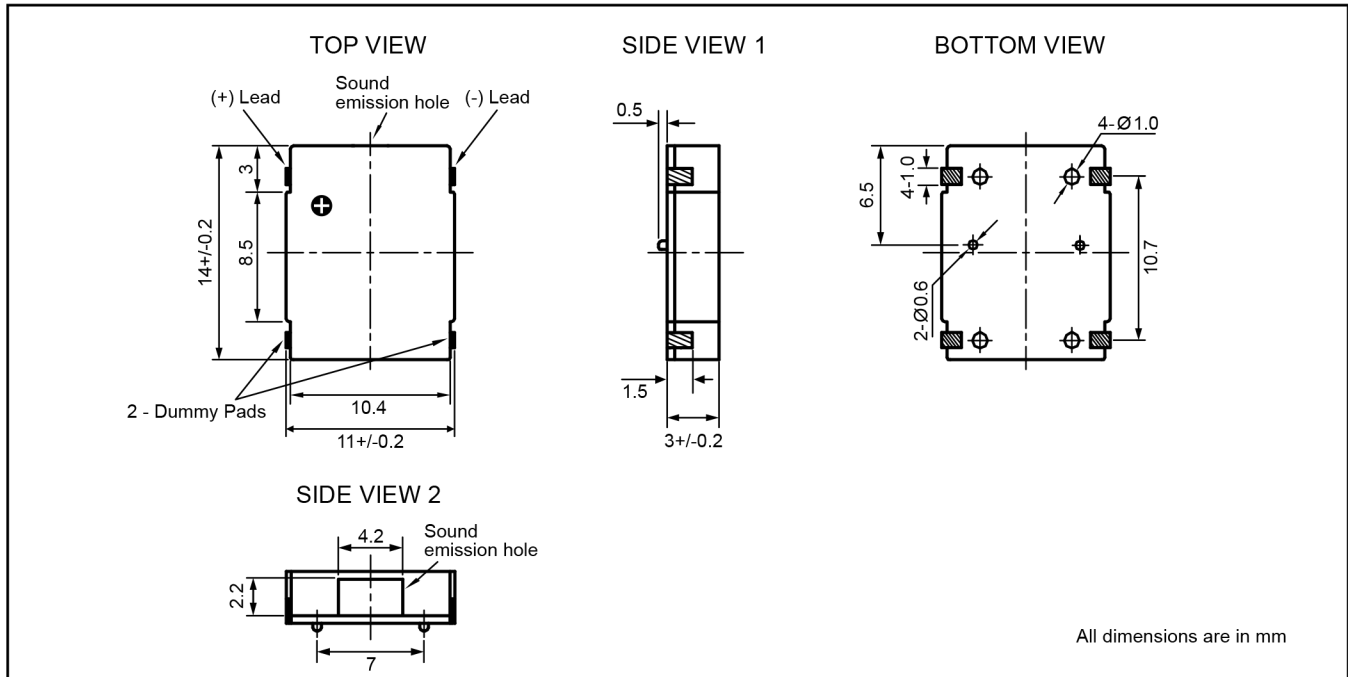

Ref. no.: -

Special Description : LD-BZEL-T15-14113 to fulfil RoHS regulation, (Lead Free version)

ELECTRICAL SPECIFICATIONS

Model No.	LD-BZEL-T15-14113
Operating Voltage <input type="checkbox"/> [V]	2 ~ 4
Rated Voltage <input type="checkbox"/> [V]	3
* Max. Rated Current <input type="checkbox"/> [mA]	80
Coil Resistance <input type="checkbox"/> [ohm]	18 +/- 3
* Min. Sound Output <input type="checkbox"/> [dB / 10cm]	87
Resonant Frequency <input type="checkbox"/> [Hz]	2730
Operating Temperature <input type="checkbox"/> [°C]	-30 ~ +85
Terminal	SMD
Housing Material	LCP (Pb free version)
Colour	Black
Weight <input type="checkbox"/> [gm]	1

* Value applying rated voltage [resonant frequency, 1/2 duty, square wave] and recommended circuit [HFE >200, min.2.5mA]