

# ISP1880

## BT5 Accelerometer-Magnetometer, Temperature/Humidity and Barometer Sensor

This small Multi Sensor demonstrator provides an example of the tremendous capabilities of the ISP1807 module based on nRF52840 Chip. With several sensors around a powerful Cortex™ M4 CPU, flash and RAM memory combined with an optimized antenna, ISP1880 offers the best in class Bluetooth 5 performance and low power consumption.



### Key Features

- Bluetooth v5.0 - 2.4GHz low energy RF Transceiver
- Based on Insight SiP 1807-LR Module
- 32bit ARM Cortex M4F CPU with 1MB Flash and 256KB RAM
- Fully integrated RF matching and Antenna
- Integrated 32 MHz and 32.768 kHz Clocks
- Low Power 3-Axis Accelerometer Detection
- Low Power Temperature/Humidity Detection
- Low Power Barometer Detection
- Programmable controlled mini LED
- USB port interface
- Power supply on coin cell battery CR2032 or with USB interface
- Overall Size 32 x 26.5 mm<sup>2</sup>
- Temperature -25 to 85 °C

### Applications

- Sport and fitness sensors
- Health care sensors
- Industrial sensors
- Gaming sensors
- Motion detection and transmission



### Certifications

- FCC certification pending
- CE certification pending
- IC certification pending
- TELEC certification pending
- Bluetooth SIG certification pending
- RoHS compliant

## Contents

1.	Block Diagram .....	2
2.	Specifications .....	3
3.	Electrical Schematic .....	4
4.	Product Development Tools .....	7

## 1. Block Diagram

ISP1880 is an autonomous low-power device for wireless acceleration, temperature, humidity and barometer detection and transmission. Overall size of the device is 32 x 26.5 mm<sup>2</sup>.

The complete device makes use of Insight SiP ISP1807-LR Long Range BT5 module together with low power 3-axis Accelerometer, Temperature / Humidity and Barometer sensors connected to a primary button cell battery CR2032.

The host processor that handles the autonomous sensor application, the BT5 protocol stack and the communication with the sensors is a low power 32-bit MCU (ARM Cortex-M4F based), integrating 1 MB Flash memory and 256 KB RAM.

The ST Micro LSM9DS1 3-axis linear accelerometer and 3-axis magnetometer is used to detect acceleration and is combined with the ST Micro LPS22HB Barometer and the SHTC3 Sensirion Humidity / Temperature sensors. A Rohm SML-P11MTT86 mini-LED is also part of the board and is available to be controlled by software. Data are transmitted via GPIO processor port.

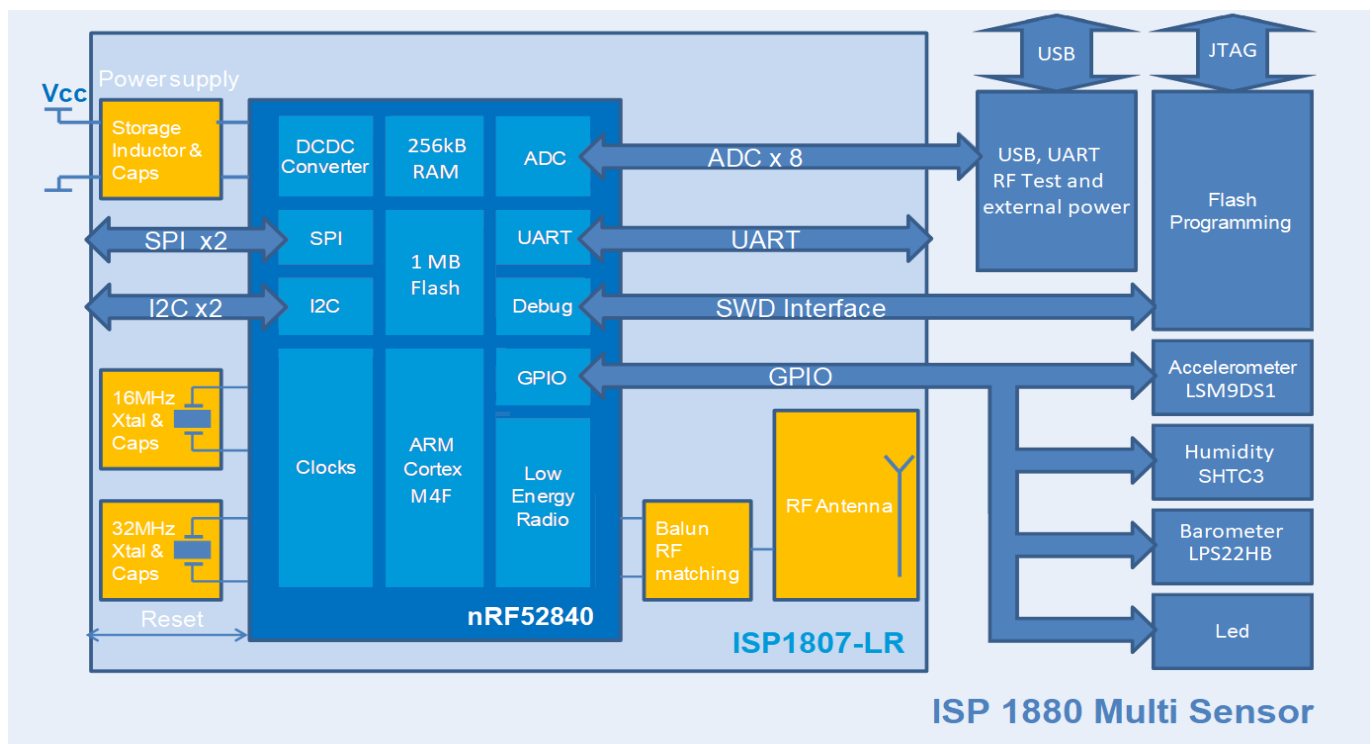

## 2. Specifications

### Sensor Performances

This chart summarizes main sensor ranges, sensitivities and accuracies. For more detailed information, please refer to the manufacturer datasheet.

Parameter	Min	Typ	Max	Unit
Linear Acceleration range	±2		±16	g (9.81m/s <sup>2</sup> )
Linear Acceleration sensitivity	0.061		0.732	mg/LSB
Linear Acceleration accuracy @ ±8g range		±90		mg
Magnetic measurement range	±4		±16	Gauss
Magnetic measurement sensitivity	0.14		0.58	mG/LSB
Angular rate range	±245		±2000	dps
Angular rate sensitivity	8.75		70	mdps/LSB
Barometer range	800		1100	hPa
Barometer sensitivity		4096		LSB/hPa
Barometer accuracy		±0.1		hPa
Relative Humidity range	0		100	%RH
Relative Humidity accuracy		±2		%RH
Temperature range	-25		+85	°C
Temperature accuracy		±0.2		°C

### RF Specifications

The performance of Bluetooth 5 radio is related to ISP1807-LR specification.

Parameter	Min	Typ	Max	Unit
Frequency Range	2360		2500	Mhz
Maximum Output Power		8		dBm
Rx Sensitivity Level, BLE1 Mbps		-95		dBm
Rx Sensitivity Level, BLE Long Range 125 kbps		-103		dBm
Antenna Gain		0.6		dBi
EIRP	-19.4		8.6	dBm
Range Open field @1m height		100		M
Data Rate	125		2000	kbps

## 3. Electrical Schematic

### ISP1807 Connections

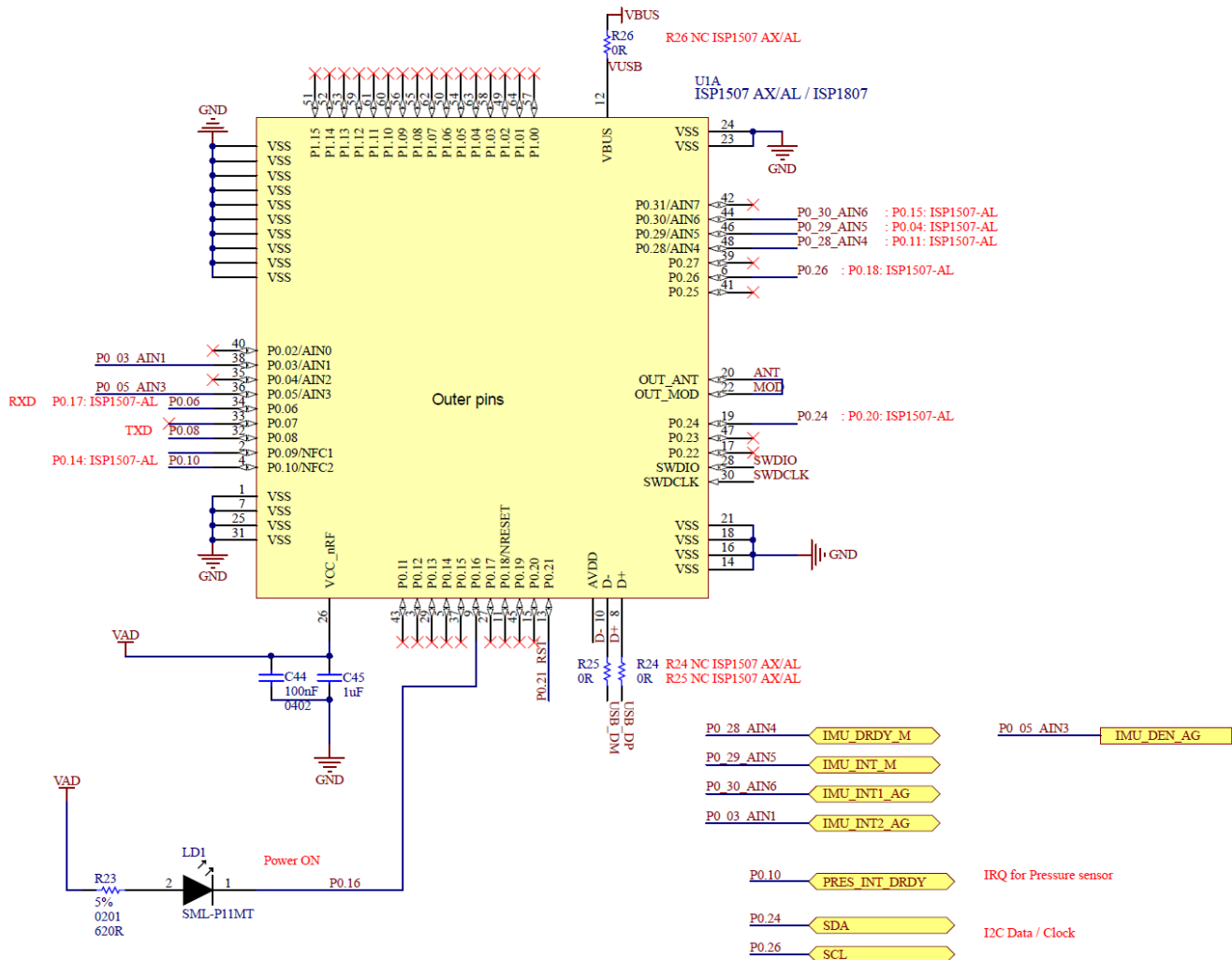

## Sensor connections

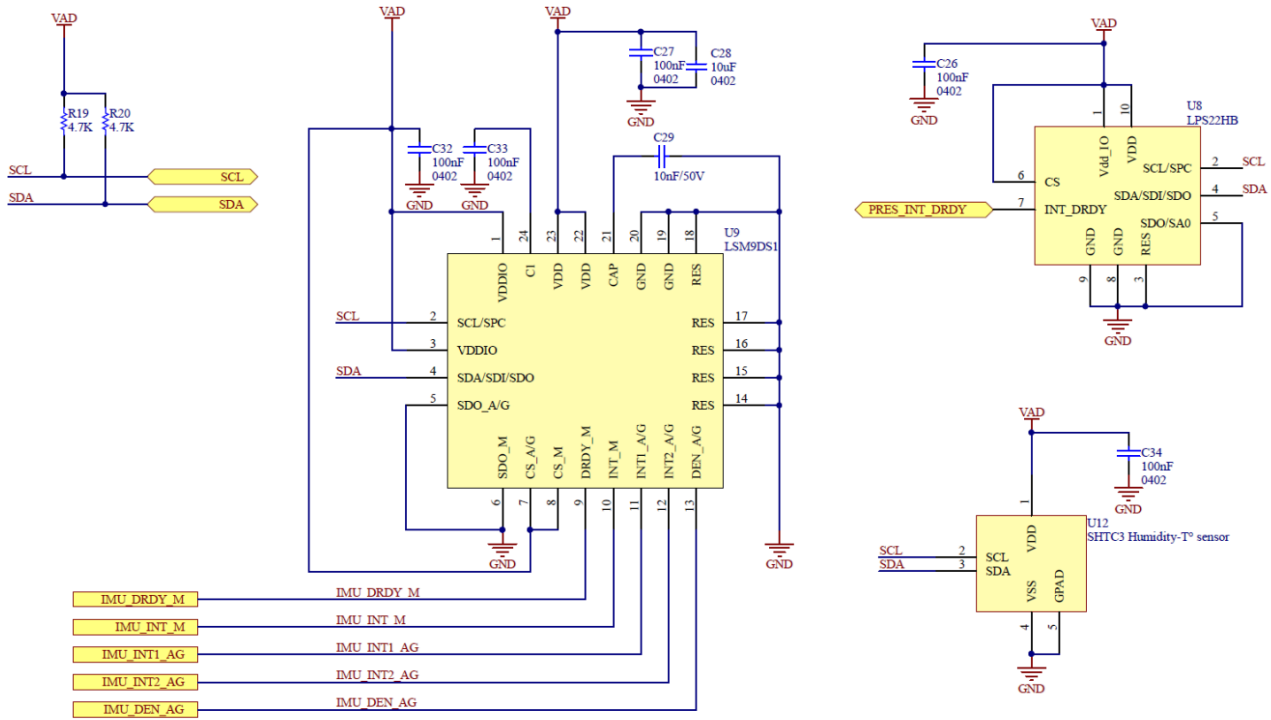

## USB Connections

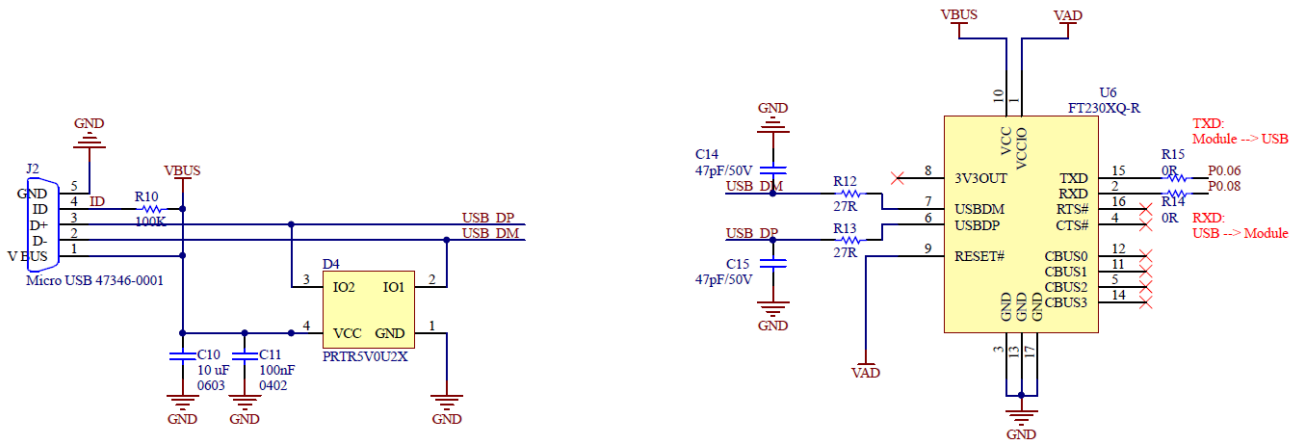

## Power Supply

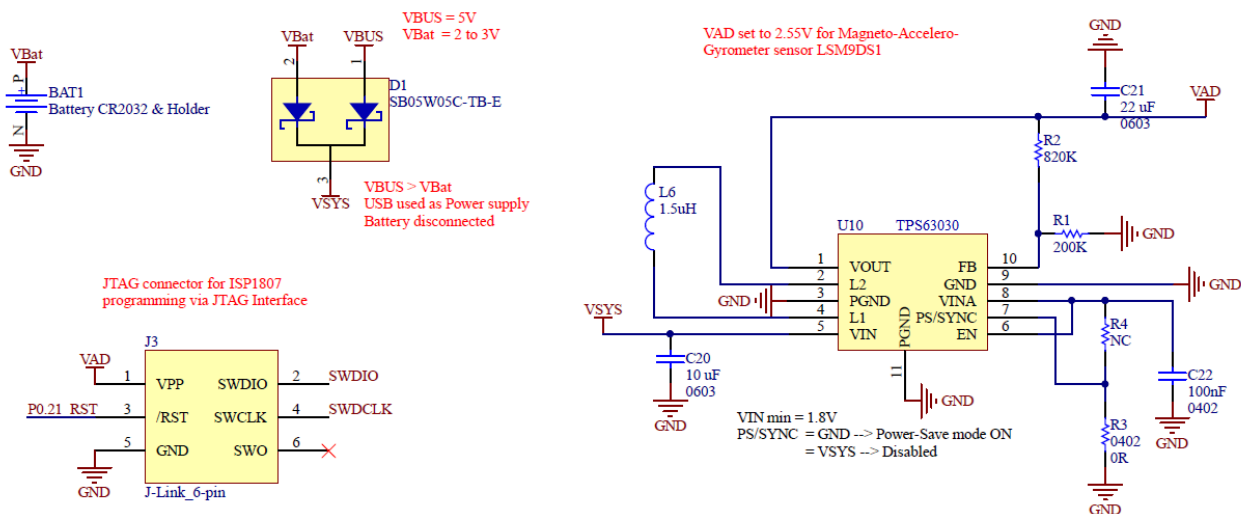

---

## 4. Product Development Tools

---

### Hardware

In order to assist clients in using ISP1880 Sensor application based on the ISP1807 module, Insight SiP provide an application note that can be downloaded here:

[http://www.insightsip.com/fichiers\\_insightsip/pdf/ble/ISP1807/isp\\_ble\\_AN181105.pdf](http://www.insightsip.com/fichiers_insightsip/pdf/ble/ISP1807/isp_ble_AN181105.pdf)

For further specific development, it is also possible to acquire an Evaluation Board containing:

- One Interface Board with J-Link Seeger integrated
- One ISP1807-LR Test Board
- Cables
- NFC Antenna

Using this evaluation board, product developers can use a working solution as starting point to develop their own applications. Please refer to the documentation for more information:

[http://www.insightsip.com/fichiers\\_insightsip/pdf/ble/ISP1807/isp\\_ble\\_DS1807\\_DK.pdf](http://www.insightsip.com/fichiers_insightsip/pdf/ble/ISP1807/isp_ble_DS1807_DK.pdf)

[http://www.insightsip.com/fichiers\\_insightsip/pdf/ble/ISP1807/isp\\_ble\\_AN181104.pdf](http://www.insightsip.com/fichiers_insightsip/pdf/ble/ISP1807/isp_ble_AN181104.pdf)

### Firmware

ISP1807 supports Bluetooth Low Energy protocol stack S140 SoftDevice. It also provides extensive software support for ANT and THREAD applications as well as 2.4 GHz protocol stacks, including Gazell. All are available as downloads at [www.nordicsemi.com](http://www.nordicsemi.com).

Additional development tools and software are recommended for using and testing ISP1880:

- ✚ Nordic Semiconductor nRFgo Studio:  
Downloadable after registering at [www.nordicsemi.com](http://www.nordicsemi.com).
- ✚ Nordic Semiconductor Master Control Panel:  
Downloadable after registering at [www.nordicsemi.com](http://www.nordicsemi.com).
- ✚ Debugging and IDE:  
SEGGER Embedded Studio (SES):  
Downloadable from <https://www.segger.com/products/development-tools/embedded-studio/>
- ✚ Segger J-Link Lite:  
Downloadable from <http://www.segger.com/jlink-software.html>.
- ✚ nRF52 Software Development Kit (SDK). It can be downloaded after registering at [www.nordicsemi.com](http://www.nordicsemi.com). It contains example applications and provides source codes, precompiled HEX files, SES, Keil and IAR project files