

## Levelling parts

Steel / Stainless Steel

### SPECIFICATION

#### Version in Steel ST

blackened

Spherical washer  
Steel, case-hardened

#### Version in Stainless Steel NI

AISI 303

Spherical washer  
AISI 303

Cylinder head screw DIN 912  
Stainless Steel A2-70

Washer DIN 433  
Stainless Steel AISI 304



### INFORMATION

Levelling parts GN 355 are used for levelling and adjustment in machines and equipment.

They consist of a levelling screw, a cylinder screw with disk and a spherical washer. After making the adjustment using the assembly tools GN 355.1 (see page 1315) available as accessory, the screw is tightened firmly causing the levelling screw and the spherical washer DIN 6319 underneath to spread and is so secured against twisting in the taphole.

The values for  $w$  and  $x$  given in the table and for the static load capacity are to be seen as reference values which may differ depending on the prevailing situation. In general, they do not constitute a warranty of condition. The user must determine whether the product is suitable for the intended purpose.

### ACCESSORY

- Assembly tools GN 355.1 (Code no. see table)

### TECHNICAL INFORMATION

- Stainless Steel characteristics (see page A26)

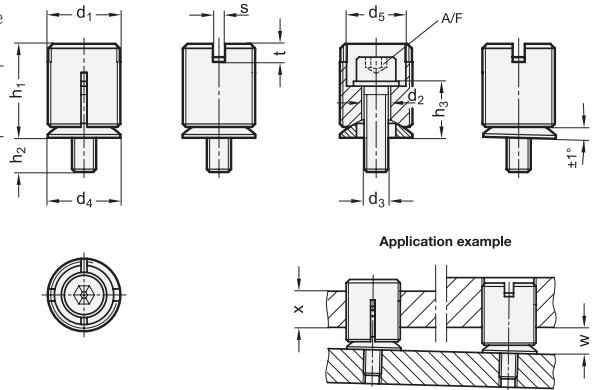

### GN 355

Description	d1	d2	d3	d4	d5	h1	h2	h3	s	A/F	t	w max.	x min.	Static load F in kN	Code no. assembly tool	⚖️
GN 355-M12x1-4,5-ST	M 12 x 1	4.5	M 4	12	9.1	19.1	10.9	9.1	2	3	3	8	8	4.4	GN 355.1-12	20
GN 355-M18x1-7-ST	M 18 x 1	7	M 6	17	12.6	26.8	10.1	14.9	2	5	3	13	12	10	GN 355.1-18	36
GN 355-M24x1,5-9-ST	M 24 x 1.5	9	M 8	24	19.6	31.1	11.3	18.7	4	6	6	16	16	27	GN 355.1-24	68
GN 355-M30x1,5-13-ST	M 30 x 1.5	13	M 12	30	25.6	32.6	20.4	19.6	4	10	6	17	20	40	GN 355.1-30	130
GN 355-M36x1,5-18-ST	M 36 x 1.5	18	M 16	36	31.6	45.7	15.8	24.2	4	14	6	19	24	70	GN 355.1-36	228

### GN 355-NI

STAINLESS STEEL

Description	d1	d2	d3	d4	d5	h1	h2	h3	s	A/F	t	w max.	x min.	Static load F in kN	Code no. assembly tool	⚖️
GN 355-M12x1-4,5-NI	M 12 x 1	4.5	M 4	12	9.1	19.1	10.9	9.1	2	3	3	8	8	4.4	GN 355.1-12	21
GN 355-M18x1-7-NI	M 18 x 1	7	M 6	17	12.6	26.8	10.1	14.9	2	5	3	13	12	10	GN 355.1-18	36
GN 355-M24x1,5-9-NI	M 24 x 1.5	9	M 8	24	19.6	31.1	11.3	18.7	4	6	6	16	16	27	GN 355.1-24	63
GN 355-M30x1,5-13-NI	M 30 x 1.5	13	M 12	30	25.6	32.6	20.4	19.6	4	10	6	17	20	40	GN 355.1-30	124
GN 355-M36x1,5-18-NI	M 36 x 1.5	18	M 16	36	31.6	45.7	15.8	24.2	4	14	6	19	24	70	GN 355.1-36	227