



# Humidity & Temperature Transmitter

**E2228**

User Manual

# Table of contents

Specifications	3
Product description	5
Safety requirements	5
Operating conditions	5
Installation and connections	6
Sensor probe handling	10
Delivery set	11
Order code for E2228 options	11
Calibration	12
Emergency mode	12
Return to default settings	12
Modbus RTU Communication	13
RS485 communication interface	14
Communication parameters	14
Modbus holding registers	14
Warranty	20
Manufacturer contacts	20

## Specifications

Sensors	Digital combined RH and T sensor
Measurement range	0...100 % RH, 40...+85 °C or -40...+125 °C (with HT-RP16-H probe), non-condensing
Resolution	0,1 %RH 0,1 °C
Accuracy	±2,5 % RH / ±0,3 °C ±1,8 % RH / ±0,3 °C on request
Self-diagnostics	Full functionality check at start-up
Response time	~15 seconds
Power supply (Us)	12...36 VDC (default), 24 VAC or 230 VAC as options
Power consumption	< 1,5 VA
Analog outputs	2 × 4-20 mA / 0-10 V, user settable, Freely configurable scales
Load resistance	$R_L < (U_s - 2 V) / 22 \text{ mA}$ for 4-20 mA $R_L > 250 \text{ k}\Omega$ for 0-10 V mode
Digital interface	RS485, Modbus RTU protocol no galvanic isolation
Cable connections	Screwless spring loaded terminals
Probe connector	Round industrial M12, IP68
Probe options	Standard: HT-RP16: black painted aluminium body Ø16 × L75 mm, IP54 protection, 0...100% RH, -40...+85 °C (non-condensing), may be connected via PVC-insulated cable 2,5 or 5 m
	Micro HT-RP04: stainless steel body Ø4 × L50 mm, IP54 protection, 0...100% RH, -40...+85 °C (non-condensing), attached PVC-insulated cable 2,5 or 5 m
	Heavy duty HT-RP16H: black painted aluminium body Ø16 × L75 mm, IP54 protection, 0...100% RH, -40...+125 °C (non-condensing), attached PTFE-insulated cable 2,5 or 5 m
Enclosure	Grey ABS, wall mount, protection class IP65
Dimensions	H82 × W80 × D55 mm

Weight	<450 g
Operating environment	Residential and office indoor spaces
Operating conditions	-40...+85 °C, 0...100 %RH (non-condensing) without aggressive gases (for main unit)
CE marking	According to 2014/30/EU: EN 61000-6-3:2020, EN 61326-1:2013(EMC, emissions) EN 61000-6-1:2019, EN 61000-6-2:2019(EMC, Immunity)

## Product description

Heavy duty humidity & temperature transmitter E2228 is a member of the new PluraSens® family of multifunctional measurement instruments. The transmitter is intended for measurement of relative humidity and temperature in air and nonaggressive gases with high accuracy and stability. Absolute humidity and dew point values can be found as well.

The instrument utilises digital fully calibrated and temperature compensated combined relative humidity and temperature sensors with excellent repeatability and stability. Thanks to the digital interface the sensor probes are detachable and fully interchangeable. The range of probes for different applications may be attached to the main unit using standard water- and dustproof M12 connectors.

Two freely configurable 4-20 mA or 0-10 V analog outputs can be used to connect the transmitter to secondary instruments. Each output can be independently assigned either to temperature, relative/absolute humidity or dew point channel.

RS485 Modbus RTU digital communication interface allows easy instrument configuration and integration into various automation systems.

Two relays RE1 and RE2 with closing contacts can be freely configured and used to switch various 24 V or 230 V powered actuators for alarming or humidity and/or temperature regulation.

## Safety requirements

Always adhere to the safety provisions applicable in the country of use.

Do not perform any maintenance operation with the power on. Do not let water or foreign objects inside the device.

## Operating conditions

The device should be used in explosion-safe (non ATEX -rated) indoor areas, without aggressive gases in the atmosphere. Allowed conditions are:

- Temperature in the range of -40...+85 °C;
- Relative humidity in the range of 0...100%;
- Non-condensing;
- Atmospheric pressure in the range of 84...106,7 kPa.

## Installation and connections

Attach the four cross-shaped brackets to the rear side of the device using four short screws (supplied with the instrument). Mark and drill four mounting holes on the wall at the chosen place (see dimensional drawing) and fix the instrument using four screws with plastic dowels (supplied with the instrument). If you use a version with HT-RP16 probe, connect the sensor probe to the device main unit directly or via connecting cable.

Unscrew four lid screws and detach the lid from the instrument.

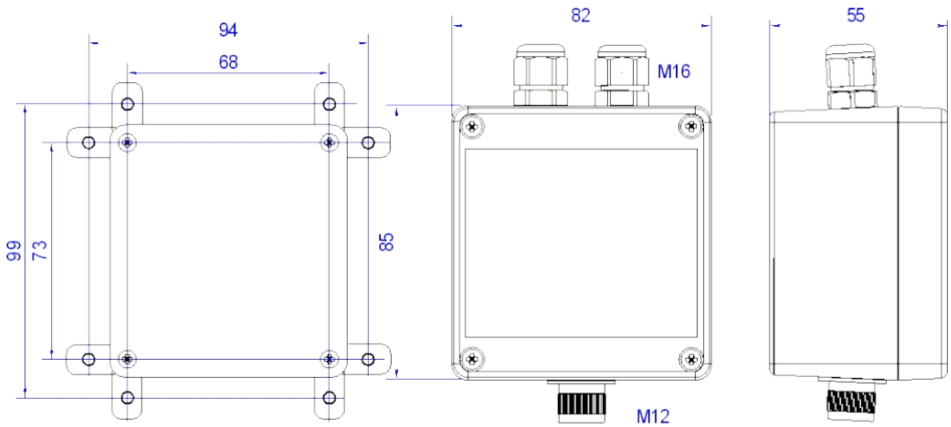

Plug the power cable and connect the analog / relay outputs and / or digital interface terminals to the relevant devices according to the connection diagram below.

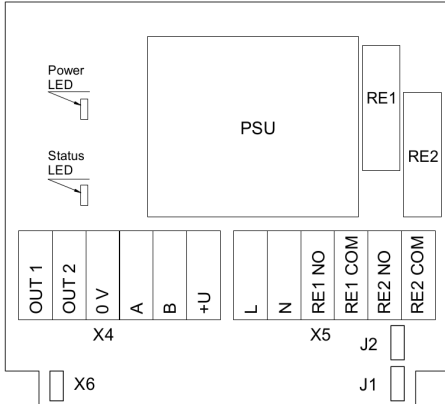

Version with PSU and relays

<b>Jumpers</b>	
<b>J1</b>	OUT1 type (open: 4-20 mA; closed 0-10 V)
<b>J2</b>	OUT2 type (open: 4-20 mA; closed 0-10 V)
<b>X6</b>	Reset Modbus network parameters to default
<b>X4 terminals</b>	
<b>OUT1</b>	4-20 mA / 0-10 V output
<b>OUT2</b>	4-20 mA / 0-10 V output
<b>0V</b>	0 V / 24 VAC Neutral (optional)
<b>A</b>	RS485 A / Data +
<b>B</b>	RS485 B / Data -
<b>+U</b>	+24 VDC / 24 VAC Phase (optional)

The screwless quick connect spring terminals on the E2228 are suitable for a wide range of wires with cross-section 0,2...1,5 mm<sup>2</sup>. The recommended wire stripping length is 8...9 mm. Push the spring loaded terminal lever, insert the wire end into the terminal hole and release the lever.

Use twisted pair cable, e.g. LiYY TP 2×2×0,5 mm<sup>2</sup> or CAT 5, to connect the device to the RS485 network. Use one pair for A and B wires and the second pair for common 0V and power +U wires. to connect the transmitter to the Fieldbus network.polarity must be respected when connecting to an external RS485 network.

Overall length of all connections via RS485 interface should not exceed 1200 m.

**NOTE!** The outputs are not galvanically isolated from the external power supply and share common 0V. Allowed load resistance limits are stated in the Specifications table. To power the instrument from an external power source, connect terminals 0V and +U to the source. If the integrated mains power supply module is used, connect terminals L and N to the mains.

**NOTE!** Actuator short-circuits should be avoided, to protect the instrument relays, use external fuses or safety switches.

Both analog outputs can be independently changed between 4-20 mA and 0-10 V type using jumpers J1 (OUT1) and J2 (OUT2). By closing pins on a specific jumper the related output is 0-10 V, with an open jumper the output is 4-20 mA. Power restart is required after changing the position of the jumpers.

By default the output OUT1 is assigned to relative humidity with default scale 0-100 %RH.

By default the output OUT2 is assigned to temperature with default scale 0-100 °C.

The output assignments and scales can be changed by Modbus commands.

Place the lid back and tighten it with the four screws.

Both analog outputs can be independently changed between 4-20 mA and 0-10 V type using jumpers J1 (OUT1) and J2 (OUT2). By closing pins on a specific jumper the related output is 0-10 V, with an open jumper the output is 4-20 mA. Power restart is required after changing the position of the jumpers.

By default the output OUT1 is assigned to relative humidity with default scale 0-100 %RH.

By default the output OUT2 is assigned to temperature with default scale 0-100 °C.

The output assignments and scales can be changed by Modbus commands.



Turn on the power. A LED placed on the PCB of the device allows control of the connection process. The LED response to different processes is presented in the table below.

<b>Mode</b>	<b>LED mode</b>
During calibration mode or sensor heating period (if activated)	0.5 Hz (50% on, 50% off)
Relay 1 turned on	Blinking 1 Hz (50% on, 50% off)
Relay 2 turned on	Blinking 2 Hz (50% on, 50% off)
During the Modbus communication cycle	Short on-off pulses
Normal operating/measurement	Continuously on or off

Make sure that the device is properly fixed, the external devices connected, power on and control LED is constantly lit. Make certain that the cable gland is properly tightened to ensure the conformity to IP65 protection class. Place the lid back and tighten it with the four screws. The device is ready to use.

## Sensor probe handling

The sensor probes HT-RP16 and HT-RP16H are equipped with a hydrophobic microporous PTFE filter to protect the sensor from dust, dirt and water drops. The round filter is snap-fitted and may be replaced if it gets strongly contaminated.

To replace the PTFE filter, carefully hook the filter near its edge with a small flat screwdriver and pull it off. Place a new filter onto the sensor opening and press it to snap into the groove.

**Note!** Never stab or press the filter near its center where the sensor is located, as this may damage the sensor. Do not remove the filter as it may cause the device to show incorrect values and/or break the sensor.

The recommended orientation of the sensor probe is vertical with the sensor tip pointing downwards. This prevents possible accumulation of condensed water on the sensor protection filter. The horizontal orientation is also suitable. Avoid upward position of the sensor tip.

After replacing the sensor probe check if the M12 connector is securely tightened to ensure appropriate electrical contact and protection.

Sensor probe HT-RP16

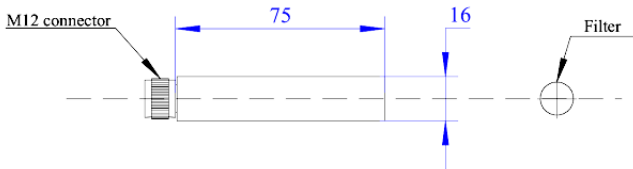

Sensor probe HT-RP04



Sensor probe HT-RP16-H

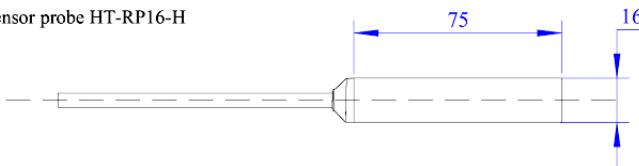

## Delivery set

- Humidity and temperature transmitter E2228
- Set of mounting accessories (4 x-shaped brackets with screws and 4 screws with plastic dowels)

### Order code for E2228 options

E2228 options	Order code
With attached probe, -40...+85 °C	E2228-RP16
Duct mount, with stem Ø16×L200 mm, -40...+85 °C	E2228-DM
With remote probe Ø16×L75 mm, 2,5 m PVC cable, -40...+85 °C	E2228-RP16-2
With remote probe Ø16×L75 mm, 5,0 m PVC cable, -40...+85 °C	E2228-RP16-5
With micro remote probe Ø4×L50 mm, 2,5 m PVC cable, -40...+85 °C	E2228-RP04-2
With micro remote probe Ø4×L50 mm, 5,0 m PVC cable, -40...+85 °C	E2228-RP04-5
With heavy-duty remote probe Ø16×L75 mm, 2,5 m PFA cable, -40...+125 °C	E2228-RP16H-2
With heavy-duty remote probe Ø16×L75 mm, 5,0 m PFA cable, -40...+125 °C	E2228-RP16H-5
High accuracy ±1,8 %RH	E2228-A
Integrated 90...265 V mains power supply module	E2228-230

## Calibration

E2228 devices have been calibrated by the Manufacturer with appropriate humidity standards before delivery. If sensors are exposed to a contaminated or aggressive environment, the instrument requires regular, at least annual field recalibration. Please contact your seller for more information.

## Emergency mode

The current outputs of the transmitter may be programmed via Modbus commands (register 255) to signal if the connection with the sensor is lost. The signal may be set to 3.8 mA or 21.5 mA.

## Return to default settings

To reset the device's Slave ID, baud rate and stop bit number to factory settings, proceed as follows:

1. De-energize the device
2. Connect the X6 jumper
3. Turn on the device
4. De-energize the device
5. Disconnect the X6 jumper
6. Turn on the device

**NOTE!** Cables should be connected/disconnected from PCB when the power supply is unplugged. Connecting or Disconnecting Live wires can result in Corrupt Firmware.

## Modbus RTU Communication

### Modbus main holding registers (00xxx or 40xxx): 0-based, decimal

Reg	RW	Description
1	R	hardware version
2	R	software version
3	R	product serial number
4	RW	Slave ID [1...247], default 1
5	RW	baud rate, default 9600
6	RW	response delay [1...255] ms, default 10
7	RW	stop bits , parity bit [1,2,3,4], default 1
17	RW	write '42330' to restart
168	RW	integrating time constant [0...32000] s
201	RW	OUT1 parameter, 0:none, 1:T, 2:RH
202	RW	OUT2 parameter, 0:none, 1:T, 2:RH
258	R	temperature, °C×100, signed integer
211	RW	parameter tied to relay RE1
212	RW	parameter tied to relay RE2
259	R	humidity, %RH×100, integer
261	RW	OUT1 out 0%, [±1000] °C / %RH
262	RW	OUT1 out 100%, [±1000] °C / %RH
263	RW	OUT2 out 0%, [±1000] °C / %RH
264	RW	OUT2 out 100%, [±1000] °C / %RH

**Note!** New Slave ID, baud rate and stop bits values apply after restart

Supported Modbus functions: 03 - read multiple registers, 06 - write single register

## RS485 communication interface

Databits: 8 Parity: none / odd / even Stop bits: 1 or 2 Protocol: Modbus RTU	Supported Modbus functions: 03 – Read multiple registers 06 – Write a single register
---	---

## Communication parameters

Parameter	Permitted values	Default
Supported baud rates	1200, 2400, 4800, 9600, 19200, 38400, 57600	9600
Data bits	8	8
Parity	none / odd / even	none
Stop bits	1, 2	1
Protocol	Modbus RTU	
Modbus functions	03 - Read multiple registers 06 - Write a single register	
Error codes	01 – Illegal function 02 – Illegal data address 03 – Illegal data value 04 – Slave device failure (details of last error 04 can be read from register 0x0008)	

## Modbus holding registers

Registers Reg are shown in hexadecimal 0-based format.

Modbus holding register numbers MHR are shown in decimal 1-based format, and may be addressed either from 00001 or 40001 base.

Reg (hex)	MHR (dec)	RW	Description	Supported values (dec)	Default
0x0001	(4)0002	R	Hardware version		2228
0x0002	(4)0003	R	Software version		-
0x0003	(4)0004	R	Product serial number	1...65535	-
0x0004	(4)0005	RW	Slave ID (net address) *	1...247 **	1
0x0005	(4)0006	RW	Baud Rate *	1200, 2400, 4800, 9600, 19200,	9600

				38400, 57600	
0x0006	(4)0007	RW	Response delay, ms	1...255	10
0x0007	(4)0008	RW	Stop bits, parity bit *	1 no parity bit, 1 stop bit (default after factory reset) 2 no parity bit, 2 stop bits 3 odd parity, 1 stop bit 4 even parity, 1 stop bit NOTE: 3 and 4 are available starting from the Software version 0x214 (dec. 532)	1
0x0008	(4)0009	R	Last error code	1...255	0
0x0011	(4)0018	RW	Restarts counter	write '42330' to restart the device	-
0x00A2	(4)0163	RW	Zero adjustment for temperature data, °C × 100	-32000...+32000 (-320.00...+320.00 °C)	0
0x00A3	(4)0164	RW	Slope adjustment for temperature data, % × 1000	-32000...+32000 (-32.000...+32.000 %)	0
0x00A4	(4)0165	RW	Change rate limit for temperature data, °C × 100 / s	1...32000 (0.01...320.00 °C/s), 0 = no limit	0
0x00A5	(4)0166	RW	Zero adjustment for humidity data, % RH × 100	-32000...+32000 (-320.00...+320.00 % RH)	0
0x00A6	(4)0167	RW	Slope adjustment for humidity data, % × 1000	-32000...+32000 (-32.000...+32.000 %)	0
0x00A7	(4)0168	RW	Change rate limit for humidity data, %RH × 100 / s	1...32000 (0.01...320.00 % RH/s), 0 = no limit	0
0x00A8	(4)0169	RW	Integrating filter time constant for all channels, s	1...32000 (seconds), 0 = no filter	0

Reg (hex)	MHR (dec)	RW	Description	Supported values (dec)	Default
0x00C9	(4)0202	RW	Parameter tied to analog output 1	0 - none 1 - temperature 2 - humidity 3 - dewpoint 4 - absolute humidity 9 - forced Modbus control, value set in MHR (4)0204	2
0x00CA	(4)0203	RW	Parameter tied to analog output 2	0 - none 1 - temperature 2 - humidity 3 - dewpoint 4 - absolute humidity 9 - forced Modbus control, value set in MHR (4)0205	1
0x00CB	(4)0204	RW	Forced value for analog output 1***	0...1000 (0.0%...100.0% of output scale)	0
0x00CC	(4)0205	RW	Forced value for analog output 2***	0...1000 (0.0%...100.0% of output scale)	0
0x 00D3	(4)0212		Parameter tied to relay RE1	0=none, 1=temperature, 2=humidity, 3=dewpoint, 4=absolute humidity, 9=forced Modbus control, state set in MHR (4)0214"	0
0x00D4	(4)0213		Parameter tied to relay RE2	0=none, 1=temperature, 2=humidity, 3=dewpoint, 4=absolute humidity, 9=forced Modbus control, state set in MHR (4)0215"	0
0x00D5	(4)0214		Forced state for relay RE1***	0=off, 1= on	0
0x00D6	(4)0215		Forced state for relay RE2***	0=off, 1= on	0
0x00D7	(4)0216		Switching delay for relay RE1, s	0...1000 s	0
0x00D8	(4)0217		Switching delay for relay RE2, s	0...1000 s	0



0x00D9	(4)0218		Minimal on/off time for relay RE1, s	0...1000 s	0
0x00DA	(4)0219		Minimal on/off time for relay RE2, s	0...1000 s	0

Reg (hex)	MHR (dec)	RW	Description	Supported values (dec)	Default
0x00DB	(4)0220		Control logic for relay RE1	0=none, 1=relay on at high values, 2=relay on at low values, 3=relay on at values within range, 4=relay on at values outside range "	0
0x00DC	(4)0221		Control logic for relay RE2	0=none, 1=relay on at high values, 2=relay on at low values, 3=relay on at values within range, 4=relay on at values outside range "	0
0x00DD	(4)0222		LOW setpoint for relay RE1, °C x 100 / %RH x 100 / g/m3 x 100	-32000...+32000	0
0x00DE	(4)0223		HIGH setpoint for relay RE1, °C x 100 / %RH x 100 / g/m3 x 100	32000...+32000	0
0x00DF	(4)0224		LOW setpoint for relay RE2, °C x 100 / %RH x 100 / g/m3 x 100	-32000...+32000	0
0x00E0	(4)0225		HIGH setpoint for relay RE2, °C x 100 / %RH x 100 / g/m3 x 100	-32000...+32000	0
0x00FF	(4)0256	RW	Sensor and analog outputs status	bit [0] = 0 / 1 - sensor present / absent, read-only! bit [1] = 0 / 1 - analog outputs deactivated / activated bit[2]= 0/1 - if the sensor is absent, turn signaling off/on at analog output 1,	

				<p>bit[3]=0/1 - if the sensor is absent, turn on signaling with low current/high current on analog output1; if bit[2]==0 this bit will be ignored,  bit[4]=0/1 -if the sensor is absent, turn signaling off/on at analog output 2  bit[5]=0/1 - in case of sensor absent, turn on signaling with low current/high current at analog output2; if bit[4]=0 this bit will be ignored,  bit[6]=0/1 - output 1: current/voltage output, read-only!  bit[7]=0/1 - output 2: current/voltage output, read-only!  bit[8]=0/1 - LED deactivated/activated,  bit[9]=0/1 - buzzer deactivated/activated,  bit[10]=0/1 - LED on/off (normal measurement)  NOTES: LED/buzzer signalization (if activated):  in case of detectable sensor absence or malfunction - 0.5Hz (90% off, 10% on) light and/or sound signal;  in case of Modbus response the light signal is modulated with short on-off pulses, even single Modbus cycle is visible;  normal operating- continuously on/off depending of bit[10]</p>	
0x0102	(4)0259	R	Measured temperature, °C×100	signed integer, -4000...+12500 (-40.00...+125.00 °C)	-
0x0103	(4)0260	R	Measured humidity, %RH×100	integer, 0...+10000 (0.00...100.00 %RH)	-
0x0104	(4)0261	R	Calculated dewpoint, °C×100	signed integer, -8000...+10000 (-80.00...+100.00 °C)	-
0x0105	(4)0262	RW	0% value for analog output 1, °C / % RH / g/m <sup>3</sup>	signed integer, -1000...+1000 (-1000...+1000 °C/%RH)	0

0x0106	(4)0263	RW	100% value for analog output 1, °C / % RH / g/m <sup>3</sup>	signed integer, -1000...+1000 (-1000...+1000 °C/%RH)	100
0x0107	(4)0264	RW	0% value for analog output 2, °C / % RH / g/m <sup>3</sup>	signed integer, -1000...+1000 (-1000...+1000 °C/%RH)	0
0x0108	(4)0265	RW	100% value for analog output 2, °C / % RH / g/m <sup>3</sup>	signed integer, -1000...+1000 (-1000...+1000 °C/%RH)	100
0x0119	(4)0282	R	Calculated absolute humidity, g/m <sup>3</sup> ×100	0...+32767 (0...327.67 g/m <sup>3</sup> )	-

\* – The new value is applied after restart.

\*\* – Broadcast slave ID 0 can be used to assign a new ID to the instrument with an unknown ID. When addressing by ID 0 the device shall be the only Modbus instrument in the network. The device will not respond to the Master command when addressed by ID 0.

\*\*\* – This value is dynamic and not kept in EEPROM after a restart.

## Warranty

This product is warranted to be free from defects in material and workmanship for a period of one year from the date of the original sale. During this warranty period, the Manufacturer will, at its option, either repair or replace a product that proves to be defective. This warranty is void if the product has been operated in conditions outside ranges specified by the Manufacturer or damaged by customer error or negligence or if there has been an unauthorized modification.

## Manufacturer contacts

Evikon MCI OÜ

Teaduspargi 9, Tartu

50411 Estonia

info@evikon.eu

www.evikon.eu

