

Humidity & Temperature Transmitter

E2228

 4-20 mA
 0-10 V

 RS485
 Modbus

Features

- Excellent repeatability and stability
- Fully calibrated and temperature compensated
- Heavy duty IP65 protected enclosure
- 0-10 V or 4-20 mA switchable analog outputs
- Two relays for thermostat / hygostat functionality
- RS485 Modbus RTU digital interface
- Range of remote probes

Specifications

Sensor	Digital combined RH and T sensor
Measurement range	0...100 %RH, -40...+85 °C or -40...+125 °C (with heavy duty probe HT-RP16H), non-condensing
Calculated parameters	Dew point, absolute humidity
Resolution	0,1 %RH / 0,1 °C
Accuracy	±2,5 %RH (optionally ±1,8 %RH) ±0,3 °C
Response time	~15 seconds
Self-diagnostics	Full functionality check at start-up
Warm-up time	≤ 1 s
Power supply	12...36 VDC (default), 24 VAC or 230 VAC as options
Power consumption	< 1,5 VA
Digital interface	RS485, Modbus RTU protocol
Analog outputs	2 × 4-20 mA / 0-10 V, user settable, freely configurable scales
Output relays	2 × SPST relays (closing contact), 250 VAC / 30 VDC, 5 A max
Cable connections	Screwless terminal blocks
Probe connector	Round industrial M12, IP68
Enclosure	Grey ABS, wall mount, protection class IP65
Dimensions	H85 × W82 × D55 mm
Operating environment	Industrial indoor and outdoor places
Operating conditions	-40...+85 °C, 0...100 %RH (non-condensing)
Attached probe HT-RP16	M12 connector-based, Ø16×L75 mm
Micro-probe HT-RP04	st. steel Ø4×L50 mm with vent slots, cable 2,5 m or 5 m, -40...+85 °C
Remote probe HT-RP16	Black painted aluminium Ø16×L75 mm, M12 plug, PVC cable 2,5 or 5 m, -40...+85 °C
Heavy duty probe HT-RP16H	Black painted aluminium Ø16×L75 mm, for harsh environment PTFE cable 2,5 or 5 m, -40...+125 °C

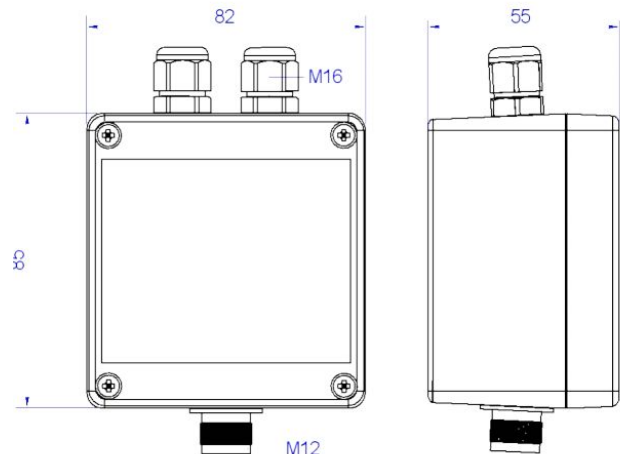

Sensor probe HT-RP16

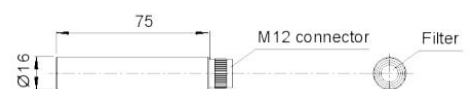

Sensor probe HT-RP04



Sensor probe HT-RP16-H

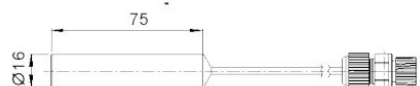

Connection diagram

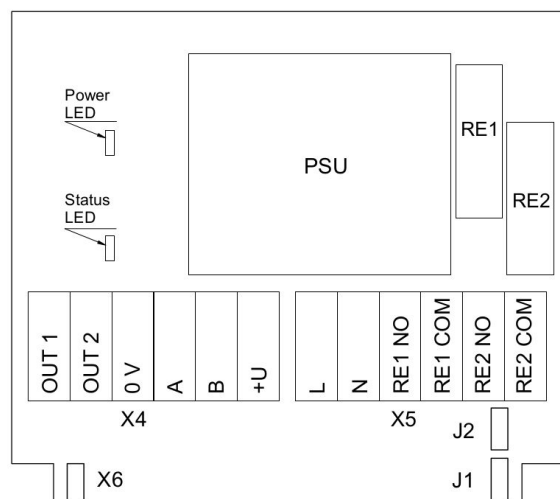

Jumpers

J1	OUT1 type (open: 4-20 mA; closed 0-10 V)
J2	OUT2 type (open: 4-20 mA; closed 0-10 V)
X6	Reset Modbus network parameters to default

X4 terminals

OUT1	4-20 mA / 0-10 V output
OUT2	4-20 mA / 0-10 V output
0V	0 V / 24 VAC Neutral (optional)
A	RS485 A / Data +
B	RS485 B / Data -
+U	+24 VDC / 24 VAC Phase (optional)

X5 terminals (optional)

L	90...265 VAC Phase
N	90...265 VAC Neutral
RE1 NO	Relay 1, normally open terminal
RE1 COM	Relay 1, common terminal
RE2 NO	Relay 2, normally open terminal
RE2 COM	Relay 2, common terminal