

PluraSens®



**Duct mount  
Humidity & Temperature Transmitter**

**E2218-DM**

User Manual

# Table of contents

Specifications	3
Product description	4
Safety requirements	4
Operating conditions	4
Installation and connections	5
Sensor probe handling	8
Delivery set	8
Order code for E2218-DM options	9
Emergency mode	9
Return to default settings	9
Modbus RTU Communication	10
Communication parameters	11
Modbus holding registers	11
Warranty	15
Manufacturer contacts	15

## Specifications

Sensors	Digital combined RH and T sensor
Measurement range	0...100 % RH, 40...+85 °C, non-condensing
Resolution	0,1 %RH 0,1 °C
Accuracy	±2,5 % RH / ±0,3 °C ±1,8 % RH / ±0,3 °C on request
Self-diagnostics	Full functionality check at start-up
Warm-up time	≤ 1 s
Response time	~15 seconds
Power supply (Us)	12...36 VDC (default) 24 VAC as option
Power consumption	< 1,5 VA
Analog outputs	2 × 4-20 mA / 0-10 V, user settable, Freely configurable scales
Load resistance	$R_L < (U_s - 2 V) / 22 \text{ mA}$ for 4-20 mA $R_L > 250 \text{ k}\Omega$ for 0-10 V mode
Digital interface	RS485, Modbus RTU protocol no galvanic isolation
Cable connections	Screwless spring loaded terminals
Probe connector	Round industrial M12, IP68
Probe	Grey painted aluminium body Ø16 × L200 mm, IP54 protection, 0...100% RH, -40...+85 °C
Enclosure	Grey ABS, wall mount, protection class IP65
Mounting accessories	25 mm plastic cable gland with time-saving CLICK system
Dimensions	H82 × W80 × D55 mm
Operating environment	Residential, Industrial and office indoor and outdoor places
Operating conditions	-40...+85 °C, 0...100 %RH (non-condensing) in non-aggressive environment (for main unit)
CE marking	According to 2014/30/EU: EN 61000-6-3:2020, EN 61326-1:2013(EMC, emissions) EN 61000-6-1:2019, EN 61000-6-2:2019(EMC, Immunity)

## Product description

Duct mount humidity and temperature transmitter E2218-DM is a member of the new PluraSens® family of multifunctional measurement instruments. The transmitter is intended for measurement of relative humidity and temperature in air and non-aggressive gases with high accuracy and stability. Absolute humidity and dew point values can be found as well.

The instrument utilises digital fully calibrated and temperature compensated combined relative humidity and temperature sensors with excellent repeatability and stability. Thanks to the digital interface the sensor probes are detachable and fully interchangeable. The range of probes for different applications may be attached to the main unit using standard water and dustproof M12 connectors.

Two freely configurable 4-20 mA or 0-10 V analog outputs can be used to connect the transmitter to secondary instruments. Each output can be independently assigned either to temperature, relative humidity or dew point channel. RS485 interface with industry-standard Modbus RTU protocol allows direct Fieldbus networking of the transmitter.

## Safety requirements

Always adhere to the safety provisions applicable in the country of use.

Do not perform any maintenance operation with the power on. Do not let water or foreign objects inside the device.

## Operating conditions

The device should be used in explosion-safe (non ATEX -rated) indoor areas, without aggressive gases in the atmosphere. Allowed conditions are:

- Temperature in the range of -40...+85 °C;
- Relative humidity in the range of 0...100%;
- Non-condensing;
- Atmospheric pressure in the range of 84...106,7 kPa.

## Installation and connections

Assemble the sensor probe and connect it to the device main unit. Make sure that the connections are tightened properly.

Cut a 25 mm diameter hole in the air duct at the chosen mounting place. Fix the 25 mm cable gland in the hole. Pass the sensor probe through the gland, adjust it to the appropriate depth and tighten the gland's screw.

Unscrew four lid screws and detach the lid from the instrument.

Plug the power cable and connect the analog outputs and/or digital interface terminals to the relevant devices according to the connection diagram.

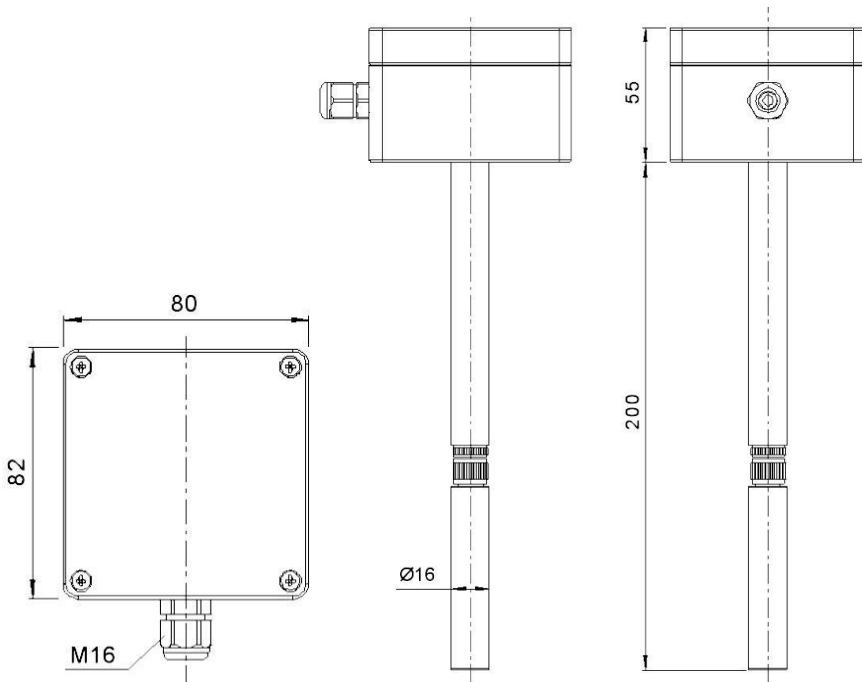

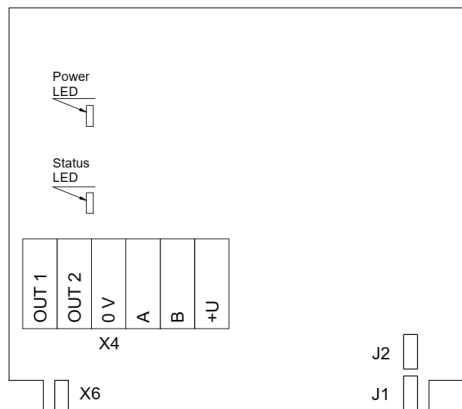

PCB without PSU and relays

<b>Jumpers</b>	
<b>J1</b>	OUT1 type (open: 4-20 mA; closed 0-10 V)
<b>J2</b>	OUT2 type (open: 4-20 mA; closed 0-10 V)
<b>X6</b>	Reset Modbus network parameters to default
<b>X4 terminals</b>	
<b>OUT1</b>	4-20 mA / 0-10 V output
<b>OUT2</b>	4-20 mA / 0-10 V output
<b>0V</b>	0 V / 24 VAC Neutral (optional)
<b>A</b>	RS485 A / Data +
<b>B</b>	RS485 B / Data -
<b>+U</b>	+24 VDC / 24 VAC Phase (optional)

Make certain that the cable gland is properly tightened to ensure the conformity to IP65 protection class.

The screwless quick connect spring terminals on the E2218 are suitable for a wide range of wires with cross-section 0,2...1,5 mm<sup>2</sup>. The recommended wire stripping length is 8...9 mm. Push the spring loaded terminal lever, insert the wire end into the terminal hole and release the lever.

Use twisted pair cable, e.g. LiYY TP 2×2×0,5 mm<sup>2</sup> or CAT 5, to connect the device to the RS485 network. Use one pair for A and B wires and the second pair for common 0V and power +U wires. to connect the transmitter to the Fieldbus network. polarity must be respected when connecting to an external RS485 network.

Overall length of all connections via RS485 interface should not exceed 1200 m.

Place the lid back and tighten it with the four screws.

Both analog outputs can be independently changed between 4-20 mA and 0-10 V type using jumpers J1 (OUT1) and J2 (OUT2). By closing pins on a specific jumper the related output is 0-10 V, with an open jumper the output is 4-20 mA. Power restart is required after changing the position of the jumpers.

By default the output OUT1 is assigned to relative humidity with default scale 0-100 %RH.

By default the output OUT2 is assigned to temperature with default scale 0-100 °C.

The output assignments and scales can be changed by Modbus commands.

## Sensor probe handling

The sensor probe is equipped with a hydrophobic microporous PTFE filter to protect the sensor from dust, dirt and water drops. The round filter is snap-fitted and may be replaced if it gets strongly contaminated.

To replace the PTFE filter, carefully hook the filter near its edge with a small flat screwdriver and pull it off. Place a new filter onto the sensor opening and press it to snap into the groove.

**Note!** Never stab or press the filter near its center where the sensor is located, as this may damage the sensor. Do not remove the filter as it may cause the device to show incorrect values and/or break the sensor.

The recommended orientation of the sensor probe is vertical with the sensor tip pointing downwards. This prevents possible accumulation of condensed water on the sensor protection filter. The horizontal orientation is also suitable. Avoid upward position of the sensor tip.

After replacing the sensor probe check if the M12 connector is securely tightened to ensure appropriate electrical contact and protection.



## Delivery set

- Humidity and temperature transmitter E2218-DM
- Cable gland Ø25 mm

### Order code for E2218-DM options

E2218-DM options	Order code
Duct mount, with stem Ø16×L200 mm, -40...+85 °C	E2218-DM
High accuracy ±1,8 %RH	E2218-DM-A

## Emergency mode

The current outputs of the transmitter may be programmed via Modbus commands (register 255) to signal if the connection with the sensor is lost. The signal may be set to 3.8 mA or 21.5 mA. See Annex 1 for more information.

## Return to default settings

To reset the device's Slave ID, baud rate and stop bit number to factory settings, proceed as follows:

1. De-energize the device
2. Connect the X6 jumper
3. Turn on the device
4. De-energize the device
5. Disconnect the X6 jumper
6. Turn on the device

**NOTE!** Cables should be connected/disconnected from PCB when the power supply is unplugged. Connecting or Disconnecting Live wires can result in Corrupt Firmware.

## Modbus RTU Communication

### Modbus main holding registers (00xxx or 40xxx): 0-based, decimal

Reg	RW	Description
1	R	hardware version
2	R	software version
3	R	product serial number
4	RW	Slave ID [1...247], default 1
5	RW	baud rate, default 9600
6	RW	response delay [1...255] ms, default 10
7	RW	stop bits , parity bit [1,2,3,4], default 1
17	RW	write '42330' to restart
168	RW	integrating time constant [0...32000] s
201	RW	OUT1 parameter, 0:none, 1:T, 2:RH
202	RW	OUT2 parameter, 0:none, 1:T, 2:RH
258	R	temperature, °C×100, signed integer
259	R	humidity, %RH×100, integer
261	RW	OUT1 out 0%, [±1000] °C / %RH
262	RW	OUT1 out 100%, [±1000] °C / %RH
263	RW	OUT2 out 0%, [±1000] °C / %RH
264	RW	OUT2 out 100%, [±1000] °C / %RH

**Note!** New Slave ID, baud rate and stop bits values apply after restart

Supported Modbus functions: 03 - read multiple registers, 06 - write single register

## Communication parameters

Parameter	Permitted values	Default
Supported baud rates	1200, 2400, 4800, 9600, 19200, 38400, 57600	9600
Data bits	8	8
Parity	none / odd / even	none
Stop bits	1, 2	1
Protocol	Modbus RTU	
Modbus functions	03 - Read multiple registers 06 - Write a single register	
Error codes	01 - Illegal function 02 - Illegal data address 03 - Illegal data value 04 - Slave device failure (details of last error 04 can be read from register 0x0008)	

## Modbus holding registers

Registers Reg are shown in hexadecimal 0-based format.

Modbus holding register numbers MHR are shown in decimal 1-based format, and may be addressed either from 00001 or 40001 base.

Reg (hex)	MHR (dec)	RW	Description	Supported values (dec)	Default
0x0001	(4)0002	R	Hardware version		2228
0x0002	(4)0003	R	Software version		-
0x0003	(4)0004	R	Product serial number	1...65535	-
0x0004	(4)0005	RW	Slave ID (net address) *	1...247 **	1
0x0005	(4)0006	RW	Baud Rate *	1200, 2400, 4800, 9600, 19200, 38400, 57600	9600
0x0006	(4)0007	RW	Response delay, ms	1...255	10
0x0007	(4)0008	RW	Stop bits, parity bit *	1 no parity bit, 1 stop bit (default after factory reset) 2 no parity bit, 2 stop bits 3 odd parity, 1 stop bit 4 even parity, 1 stop bit	1

				NOTE: 3 and 4 are available starting from the Software version 0x214 (dec. 532)	
0x0008	(4)0009	R	Last error code	1...255	0
0x0011	(4)0018	RW	Restarts counter	write '42330' to restart the device	-
0x00A2	(4)0163	RW	Zero adjustment for temperature data, °C × 100	-32000...+32000 (-320.00...+320.00 °C)	0
0x00A3	(4)0164	RW	Slope adjustment for temperature data, % × 1000	-32000...+32000 (-32.000...+32.000 %)	0
0x00A4	(4)0165	RW	Change rate limit for temperature data, °C × 100 / s	1...32000 (0.01...320.00 °C/s), 0 = no limit	0
0x00A5	(4)0166	RW	Zero adjustment for humidity data, % RH × 100	-32000...+32000 (-320.00...+320.00 % RH)	0
0x00A6	(4)0167	RW	Slope adjustment for humidity data, % × 1000	-32000...+32000 (-32.000...+32.000 %)	0
0x00A7	(4)0168	RW	Change rate limit for humidity data, %RH × 100 / s	1...32000 (0.01...320.00 % RH/s), 0 = no limit	0
0x00A8	(4)0169	RW	Integrating filter time constant for all channels, s	1...32000 (seconds), 0 = no filter	0

Reg (hex)	MHR (dec)	RW	Description	Supported values (dec)	Default
0x00C9	(4)0202	RW	Parameter tied to analog output 1	0 - none 1 - temperature 2 - humidity 3 - dewpoint 4 - absolute humidity 9 - forced Modbus control, value set in MHR (4)0204	2
0x00CA	(4)0203	RW	Parameter tied to analog output 2	0 - none 1 - temperature 2 - humidity 3 - dewpoint 4 - absolute humidity	1

				9 - forced Modbus control, value set in MHR (4)0205	
0x00CB	(4)0204	RW	Forced value for analog output 1***	0...1000 (0.0%...100.0% of output scale)	0
0x00CC	(4)0205	RW	Forced value for analog output 2***	0...1000 (0.0%...100.0% of output scale)	0
0x00FF	(4)0256	RW	Sensor and analog outputs status	<p>bit [0] = 0 / 1 - sensor present / absent, <b>read-only!</b>  bit [1] = 0 / 1 - analog outputs deactivated / activated  bit[2]= 0/1 - if the sensor is absent, turn signaling off/on at analog output 1,  bit[3]=0/1 - if the sensor is absent, turn on signaling with low current/high current on analog output1; if bit[2]=0, this bit will be ignored,  bit[4]=0/1 -if the sensor is absent, turn signaling off/on at analog output 2  bit[5]=0/1 - in case of sensor absent, turn on signaling with low current/high current at analog output2; if bit[4]=0, this bit will be ignored,  bit[6]=0/1 - output 1: current/voltage output, <b>read-only!</b>  bit[7]=0/1 - output 2: current/voltage output, <b>read-only!</b>  bit[8]=0/1 - LED deactivated/activated,  bit[9]=0/1 - buzzer deactivated/activated,  bit[10]=0/1 - LED on/off (normal measurement)  <b>Notes:</b> LED/buzzer signalization (if activated):  in case of detectable sensor absence or malfunction - 0.5Hz (90% off, 10% on) light and/or sound signal;  in case of Modbus response the light signal is modulated with short on-off pulses, even single Modbus cycle is visible;</p>	

				normal operating - continuously on/off depending of bit[10]	
0x0102	(4)0259	R	Measured temperature, °C×100	signed integer, -4000...+12500 (-40.00...+125.00 °C)	-
0x0103	(4)0260	R	Measured humidity, %RH×100	integer, 0...+10000 (0.00...100.00 %RH)	-
0x0104	(4)0261	R	Calculated dewpoint, °C×100	signed integer, -8000...+10000 (-80.00...+100.00 °C)	-
0x0105	(4)0262	RW	0% value for analog output 1, °C / % RH / g/m <sup>3</sup>	signed integer, -1000...+1000 (-1000...+1000 °C/%RH)	0
0x0106	(4)0263	RW	100% value for analog output 1, °C / % RH / g/m <sup>3</sup>	signed integer, -1000...+1000 (-1000...+1000 °C/%RH)	100
0x0107	(4)0264	RW	0% value for analog output 2, °C / % RH / g/m <sup>3</sup>	signed integer, -1000...+1000 (-1000...+1000 °C/%RH)	0
0x0108	(4)0265	RW	100% value for analog output 2, °C / % RH / g/m <sup>3</sup>	signed integer, -1000...+1000 (-1000...+1000 °C/%RH)	100
0x0119	(4)0282	R	Calculated absolute humidity, g/m <sup>3</sup> ×100	0...+32767 (0...327.67 g/m <sup>3</sup> )	-

\* – The new value is applied after restart.

\*\* – Broadcast slave ID 0 can be used to assign a new ID to the instrument with an unknown ID. When addressing by ID 0 the device shall be the only Modbus instrument in the network. The device will not respond to the Master command when addressed by ID 0.

\*\*\* – This value is dynamic and not kept in EEPROM after a restart.

## Warranty

This product is warranted to be free from defects in material and workmanship for a period of one year from the date of the original sale. During this warranty period, the Manufacturer will, at its option, either repair or replace a product that proves to be defective. This warranty is void if the product has been operated in conditions outside ranges specified by the Manufacturer or damaged by customer error or negligence or if there has been an unauthorized modification.

## Manufacturer contacts

Evikon MCI OÜ

Teaduspargi 9, Tartu

50411 Estonia

info@evikon.eu

www.evikon.eu

