

Duct mount Humidity & Temperature Transmitter E2218-DM



Features

- Excellent repeatability and stability
- Fully calibrated and temperature compensated
- Heavy duty IP65 protected enclosure
- 0-10 V or 4-20 mA switchable analog outputs
- RS485 Modbus RTU digital interface

Specifications

Sensor	Digital combined RH and T sensor
Measurement range	0...100 %RH, -40...+85 °C (non-condensing)
Calculated parameters	Dew point, absolute humidity
Resolution	0,1 %RH / 0,1 °C
Accuracy	±2,5 %RH / ±0,3 °C ±1,8 % RH / ±0,3 °C on request
Response time	~15 seconds
Self-diagnostics	Full functionality check at start-up
Warm-up time	≤ 1 s
Power supply	12...36 VDC (default) 24 VAC as option
Power consumption	< 1,5 VA
Digital interface	RS485, Modbus RTU protocol
Analog outputs	2 × 4-20 mA / 0-10 V, user settable, freely configurable scales
Fieldbus interface	RS485, Modbus RTU protocol
Cable connections	Screwless terminal blocks
Probe connector	Round industrial M12, IP68
Enclosure	Grey ABS, wall mount, protection class IP65
Dimensions	H82 × W80 × D55 mm
Operating environment	Residential, Industrial and office indoor and outdoor places
Operating conditions	-40...+85 °C, 0...100 %RH (non-condensing)
Probe	Ø16×L200 mm, M12 plug, -40...+85 °C

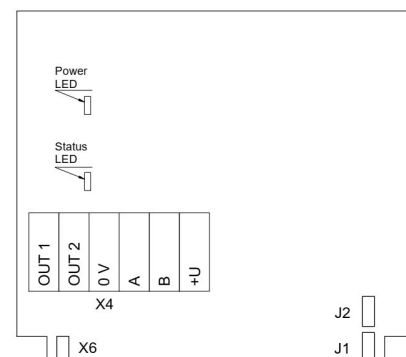
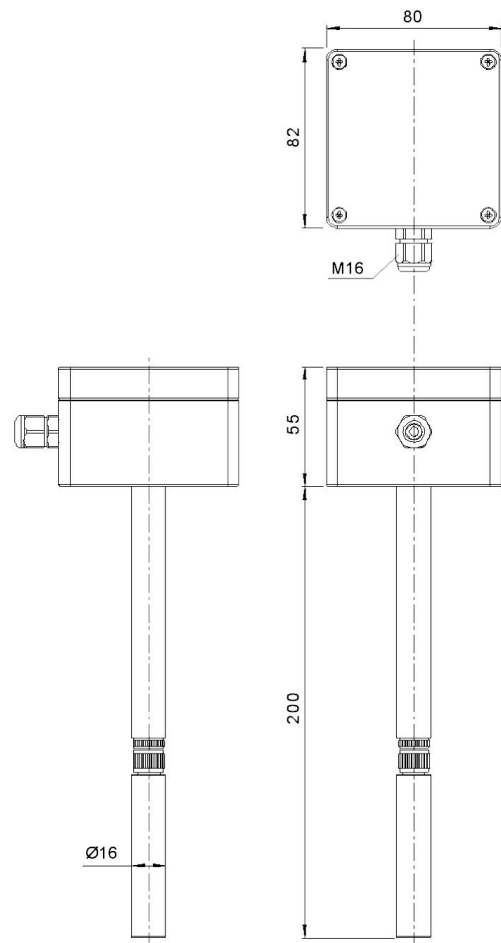

Jumpers

J1	OUT1 type (open: 4-20 mA; closed 0-10 V)
J2	OUT2 type (open: 4-20 mA; closed 0-10 V)
X6	Reset Modbus network parameters to default

X4 terminals

OUT1	4-20 mA / 0-10 V output
OUT2	4-20 mA / 0-10 V output
0V	0 V / 24 VAC Neutral (optional)
A	RS485 A / Data +
B	RS485 B / Data -
+U	+24 VDC / 24 VAC Phase (optional)