

DISPLAY Elektronik GmbH

DATA SHEET

LCD-MODULE

DEM 20490 FGH-PW

Product Specification

Ver.:0

27.09.2022

Revision History

VERSION	DATE	REVISED PAGE NO.	Note
0	27.09.2022		First Issue

Contents

- 1.General Specification
- 2.Interface Pin Function
- 3.Contour Drawing
- 4.Optical Characteristics
- 5.Absolute Maximum Ratings
- 6.Electrical Characteristics
- 7.Backlight Information
- 8.Reliability
- 9.Inspection specification
- 10.Precautions in use of LCD Modules
- 11.Material List of Components for RoHs
- 12.Recommendable Storage

1. General Specification

The Features is described as follow:

- Module dimension: 74.3 x 36.4 x 6.0 mm
- View area: 60.5 x 22.18 mm
- Active area: 58.5 x 20.18 mm
- Dot size: 0.45x 0.54 mm
- Dot pitch: 0.50 x 0.59 mm
- Character size: 2.45 x 4.67 mm
- Character pitch: 2.95 x 5.17 mm
- LCD type: FSTN Positive Transflective
- Duty: 1/33DUTY,1/6BIAS
- View direction: 6 o'clock
- Backlight Type: LED, White
- IC: IST3602
- Interface: I2C

2.Interface Pin Function

Pin	Symbol	Function Description
1	ITO ESD	Ground
2	V0	LCD Power Supply
3	VSS	Ground(VSS2&VSS3)
4	VDD	Power Supply(VDD2&VDD3)
5	VSS1	Ground(VSS1)
6	VDD1	Power Supply(VDD1)
7	SDA	Serial input data
8	SCL	Serial input clock
9	RESB	Hardware Reset input pin
10	ITO ESD	Ground

3. Contour Drawing

NO.	SYMBOL
1	ITO ESD
2	VO
3	VSS
4	VDD
5	VSSI
6	VDDI
7	SDA
8	SCL
9	RESB
10	ITO ESD

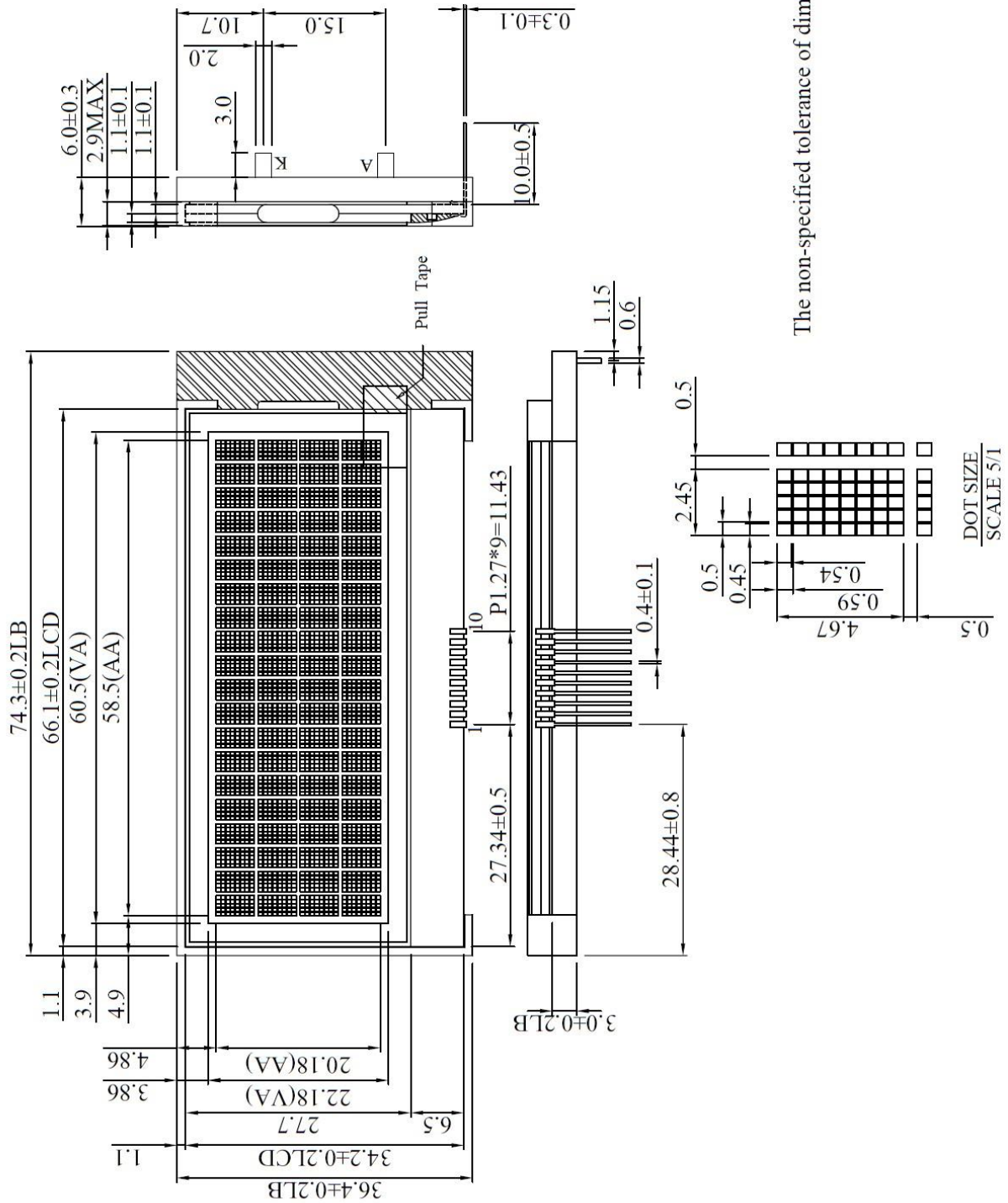

The non-specified tolerance of dimension is ± 0.3 mm.

3.1. Initial code

```

void Initial(void)
{
    RST = 1;
    delay_ms(10);
    RST = 0;
    delay_ms(10);
    RST = 1;
    delay_ms(10);

    Start();          //i2c_start
    Write_byte(0x78); // salve address

=====
    // IS Instruction Table 0
    WriteIns(0x20); //Function Set
    WriteIns(0x01); //Clear Display
    delay_ms(20);

    WriteIns(0x90); //Set DDRAM address
    WriteIns(0x00); //Set DDRAM address

    WriteIns(0x06); //Set Entry Mode
    WriteIns(0x0C); //Display Control
// =====
    // IS Instruction Table 1
    WriteIns(0x21); //Function Set : 0 0 1 0 0 0 IS2 IS1
    WriteIns(0x12); //Follows Control :0 0 0 1 0 0 BS2 BS1 Bias select:1/6B
    WriteIns(0x40); //Set ICON RAM Address
    WriteIns(0x30); //Power Control 1 :0 0 1 1 0 0 0 SLEEP
    WriteIns(0x6F); //ICON/Power Control2
    WriteIns(0x70); //Set booster ;V0 Control 2
    delay_ms(100);
// =====
    // IS Instruction Table 3
    WriteIns(0x23); //Function Set : 0 0 1 0 0 0 IS2 IS1
    WriteIns(0x81); //Contrast: VOP SET
    WriteIns(0x27); // VOP SET

    WriteIns(0x82); //start line setting
    WriteIns(0x00); //start line setting : 0 0 ST[5:0]

    WriteIns(0xA7); //Rgain set :1 0 1 0 RR[3:0]
// =====
    // IS Instruction Table 2
    WriteIns(0x22); //Function Set : 0 0 1 0 0 0 IS2 IS1
    WriteIns(0x60); //Set Display pattern : 0 1 1 0 0 0 INV AP
    WriteIns(0x13); //Set Display Mode :0 0 0 1 DH1 DH0 N2 N1 1/33D
    WriteIns(0x44); //Select CGRAM & COM/SEG direction
// =====
    // IS Instruction Table 3

```

```
WriteIns(0x23);    //Function Set   : 0 0 1 0 0 0 IS2 IS1
WriteIns(0x88);    // Set 88H 4 times to entry IST test command mode
WriteIns(0x88);
WriteIns(0x88);
WriteIns(0x88);

WriteIns(0x28);    //Frame rate adjusting enable

WriteIns(0xB2);    //1st Frame rate control
WriteIns(0xEF);    //2nd LN[7:0]
WriteIns(0x00);    //3rd LN[15:8]    95Hz

WriteIns(0x93);    //OSC Clock Select   :Fosc/1
WriteIns(0x99);    //OSC Divide Select  :750KHz

WriteIns(0xE3);    //Exit IST test command
// =====
Stop();            //i2c_stop
}
```

***NOTE:**

This Initial code is a suggested value, and customers can change the parameters according to a ctual needs.

3.2. APPLICATION EXAMPLES

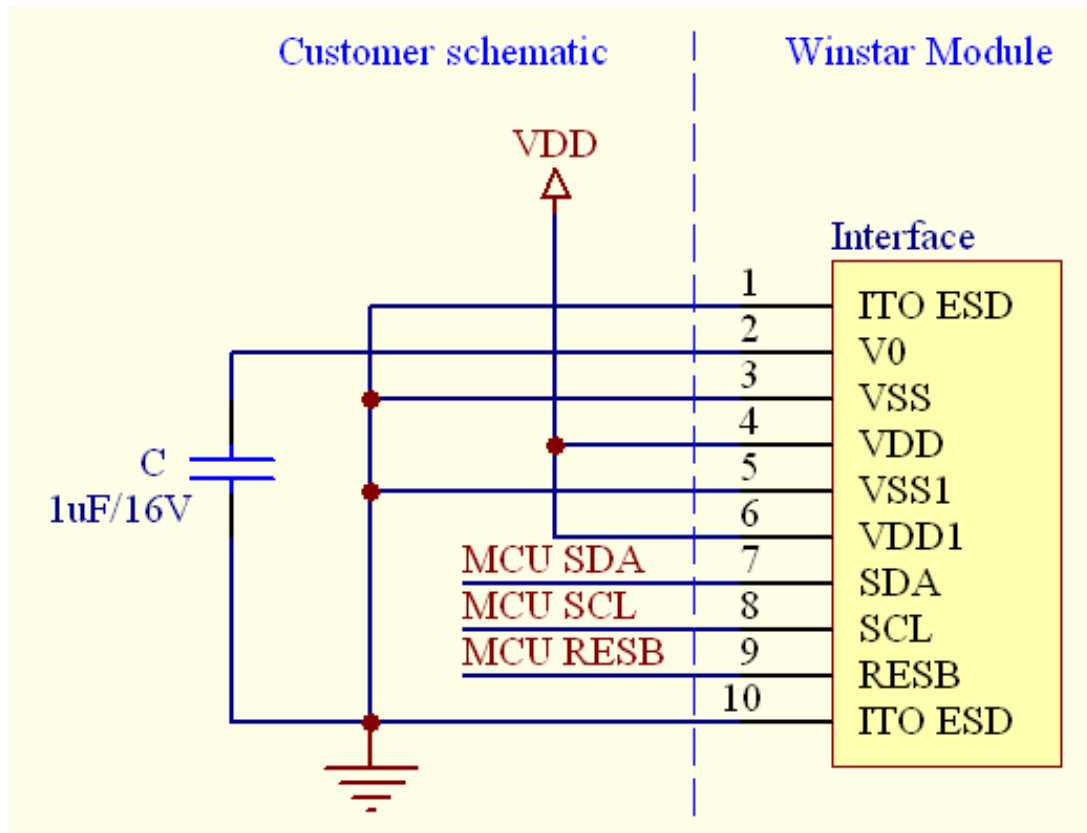

4.Optical Characteristics

Item	Symbol	Condition	Min	Typ	Max	Unit
View Angle	θ	$CR \geq 2$	0	-	30	$\psi = 180^\circ$
	θ	$CR \geq 2$	0	-	60	$\psi = 0^\circ$
	θ	$CR \geq 2$	0	-	45	$\psi = 90^\circ$
	θ	$CR \geq 2$	0	-	45	$\psi = 270^\circ$
Contrast Ratio	CR	-	-	5	-	-
Response Time	T rise	-	-	150	200	ms
	T fall	-	-	150	200	ms

Definition of Operation Voltage (Vop)

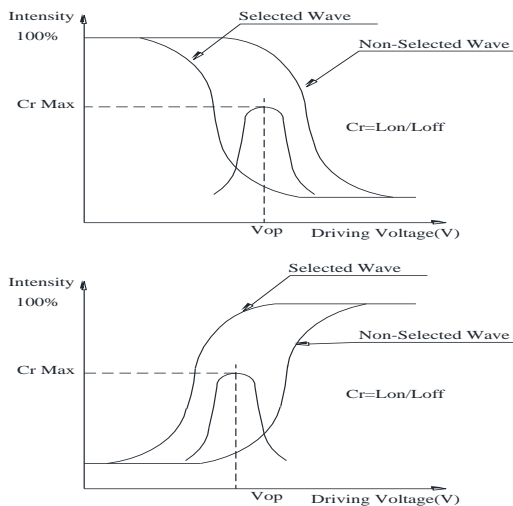

Definition of Response Time (Tr , Tf)

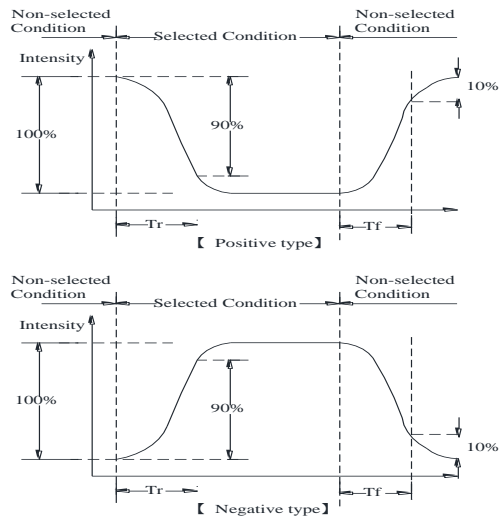

Conditions :

Operating Voltage : Vop Viewing Angle(θ , φ) : 0° , 0°
 Frame Frequency : 64 HZ Driving Waveform : 1/N duty , 1/a bias

Definition of viewing angle($CR \geq 2$)

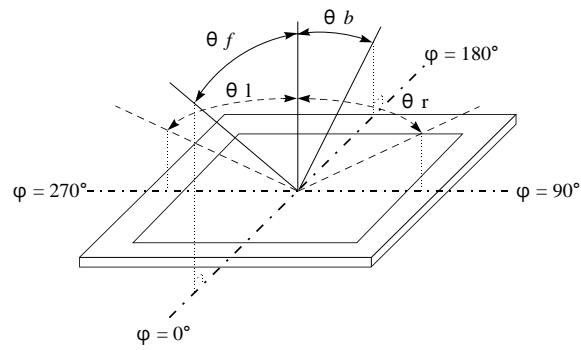

5. Absolute Maximum Ratings

Item	Symbol	Min	Typ	Max	Unit
Operating Temperature	TOP	-20	—	+70	°C
Storage Temperature	TST	-30	—	+80	°C
Input Voltage	VIN	-0.3	-	V _{DD} +0.3	V
Power Supply Voltage	V _{DD}	-0.3	-	4.0	V
LCD Driver Voltage	VLCD	-0.3	-	18.0	V

6. Electrical Characteristics

Item	Symbol	Condition	Min	Typ	Max	Unit
Supply Voltage For Logic	V_{DD}	-	2.7	3.0	3.3	V
Supply Voltage For LCD	V_O-V_{SS}	$T_a=-20^{\circ}\text{C}$	-	-	-	V
		$T_a=25^{\circ}\text{C}$	7.6	7.8	8.0	V
		$T_a=70^{\circ}\text{C}$	-	-	-	V
Input High Volt.	V_{IH}	-	$0.8 V_{DDIO}$	-	V_{DD}	V
Input Low Volt.	V_{IL}	-	V_{SS}	-	$0.2 V_{DD}$	V
Output High Volt.	V_{OH}	-	$0.8 V_{DDIO}$	-	V_{DD}	V
Output Low Volt.	V_{OL}	-	-	-	$0.2 V_{DD}$	V
Supply LCM current	I_{DD}	$V_{DD}=3.0\text{V}$	-	0.5	-	mA

Please kindly consider to design the V_{op} to be adjustable while programing the software to match LCD contrast tolerance.

7.Backlight Information

Specification

PARAMETER	SYMBOL	MIN	TYP	MAX	UNIT	TEST CONDITION
Supply Current	I _{LED}	15	48	60	mA	V=3.5V
Supply Voltage	V	-	3.5	-	V	
Reverse Voltage	V _R	-	-	5	V	
Chromaticity	X	0.25	0.28	0.31	-	
Coordinates	Y	0.25	0.28	0.31	-	
Luminance (Without LCD)	I _V	728	910	-	CD/M ²	
LED Life Time (For Reference only)	-	-	50K	-	Hr.	I _{LED} =48mA 25°C,50-60%RH, (Note 1)
Color	White					

Note: The LED of B/L is drive by current only, drive voltage is for reference only. drive voltage can make driving current under safety area (current between minimum and maximum).

Note 1:50K hours is only an estimate for reference.

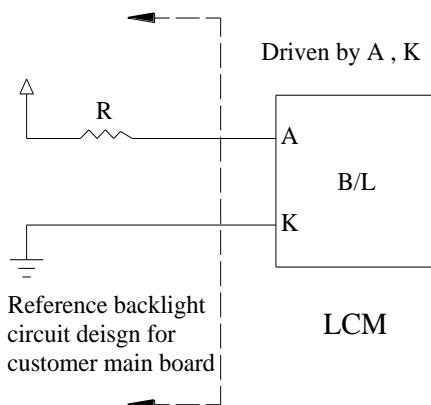

8. Reliability

Content of Reliability Test (Wide temperature, -20°C~70°C)

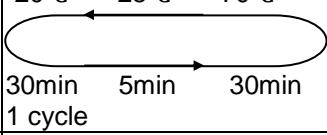
Environmental Test			
Test Item	Content of Test	Test Condition	Note
High Temperature storage	Endurance test applying the high storage temperature for a long time.	80°C 200hrs	2
Low Temperature storage	Endurance test applying the low storage temperature for a long time.	-30°C 200hrs	1,2
High Temperature Operation	Endurance test applying the electric stress (Voltage & Current) and the thermal stress to the element for a long time.	70°C 200hrs	—
Low Temperature Operation	Endurance test applying the electric stress under low temperature for a long time.	-20°C 200hrs	1
High Temperature/ Humidity storage	The module should be allowed to stand at 60°C,90%RH max For 96hrs under no-load condition excluding the polarizer, Then taking it out and drying it at normal temperature.	60°C,90%RH 96hrs	1,2
Thermal shock resistance	The sample should be allowed stand the following 10 cycles of operation -20°C 25°C 70°C  30min 5min 30min 1 cycle	-20°C /70°C 10 cycles	—
Vibration test	Endurance test applying the vibration during transportation and using.	Total fixed amplitude : 1.5mm Vibration Frequency : 10~55Hz One cycle 60 seconds to 3 directions of X,Y,Z for Each 15 minutes	3
Static electricity test	Endurance test applying the electric stress to the terminal.	VS=±600V(contact), ±800v(air), RS=330Ω CS=150pF 10 times	—

Note1: No dew condensation to be observed.

Note2: The function test shall be conducted after 4 hours storage at the normal Temperature and humidity after remove from the test chamber.

Note3: The packing have to including into the vibration testing.

9.Inspection specification

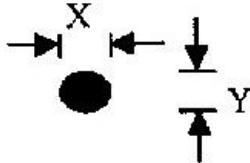
NO	Item	Criterion	AQL										
01	Electrical Testing	1.1 Missing vertical, horizontal segment, segment contrast defect. 1.2 Missing character , dot or icon. 1.3 Display malfunction. 1.4 No function or no display. 1.5 Current consumption exceeds product specifications. 1.6 LCD viewing angle defect. 1.7 Mixed product types. 1.8 Contrast defect.	0.65										
02	Black or white spots on LCD (display only)	2.1 White and black spots on display $\leq 0.25\text{mm}$, no more than three white or black spots present. 2.2 Densely spaced: No more than two spots or lines within 3mm	2.5										
03	LCD black spots, white spots, contamination (non-display)	3.1 Round type : As following drawing $\Phi = (x + y) / 2$  <table border="1" data-bbox="821 1064 1348 1500"> <thead> <tr> <th>SIZE</th> <th>Acceptable Q TY</th> </tr> </thead> <tbody> <tr> <td>$\Phi \leq 0.10$</td> <td>Accept no dense</td> </tr> <tr> <td>$0.10 < \Phi \leq 0.20$</td> <td>2</td> </tr> <tr> <td>$0.20 < \Phi \leq 0.25$</td> <td>1</td> </tr> <tr> <td>$0.25 < \Phi$</td> <td>0</td> </tr> </tbody> </table>	SIZE	Acceptable Q TY	$\Phi \leq 0.10$	Accept no dense	$0.10 < \Phi \leq 0.20$	2	$0.20 < \Phi \leq 0.25$	1	$0.25 < \Phi$	0	2.5
		SIZE	Acceptable Q TY										
$\Phi \leq 0.10$	Accept no dense												
$0.10 < \Phi \leq 0.20$	2												
$0.20 < \Phi \leq 0.25$	1												
$0.25 < \Phi$	0												
3.2 Line type : (As following drawing) <table border="1" data-bbox="710 1736 1348 2072"> <thead> <tr> <th>Length</th> <th>Width</th> <th>Acceptable Q TY</th> </tr> </thead> <tbody> <tr> <td>---</td> <td>$W \leq 0.02$</td> <td>Accept no dense</td> </tr> <tr> <td>$L \leq 3.0$</td> <td>$0.02 < W \leq 0.03$</td> <td rowspan="2">2</td> </tr> <tr> <td>$L \leq 2.5$</td> <td>$0.03 < W \leq 0.05$</td> </tr> </tbody> </table>	Length	Width	Acceptable Q TY	---	$W \leq 0.02$	Accept no dense	$L \leq 3.0$	$0.02 < W \leq 0.03$	2	$L \leq 2.5$	$0.03 < W \leq 0.05$	2.5	
Length	Width	Acceptable Q TY											
---	$W \leq 0.02$	Accept no dense											
$L \leq 3.0$	$0.02 < W \leq 0.03$	2											
$L \leq 2.5$	$0.03 < W \leq 0.05$												

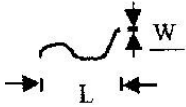
			---	$0.05 < W$	As round type												
04	Polarizer bubbles	If bubbles are visible, judge using black spot specifications, not easy to find, must check in specify direction.	<table border="1"> <thead> <tr> <th>Size Φ</th> <th>Acceptable Q TY</th> </tr> </thead> <tbody> <tr> <td>$\Phi \leq 0.20$</td> <td>Accept no dense</td> </tr> <tr> <td>$0.20 < \Phi \leq 0.50$</td> <td>3</td> </tr> <tr> <td>$0.50 < \Phi \leq 1.00$</td> <td>2</td> </tr> <tr> <td>$1.00 < \Phi$</td> <td>0</td> </tr> <tr> <td>Total Q TY</td> <td>3</td> </tr> </tbody> </table>		Size Φ	Acceptable Q TY	$\Phi \leq 0.20$	Accept no dense	$0.20 < \Phi \leq 0.50$	3	$0.50 < \Phi \leq 1.00$	2	$1.00 < \Phi$	0	Total Q TY	3	2.5
Size Φ	Acceptable Q TY																
$\Phi \leq 0.20$	Accept no dense																
$0.20 < \Phi \leq 0.50$	3																
$0.50 < \Phi \leq 1.00$	2																
$1.00 < \Phi$	0																
Total Q TY	3																

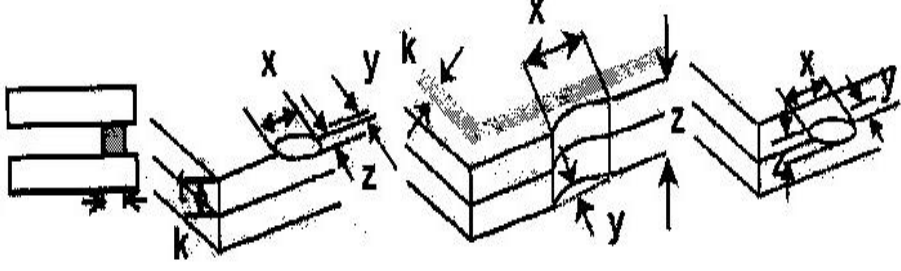
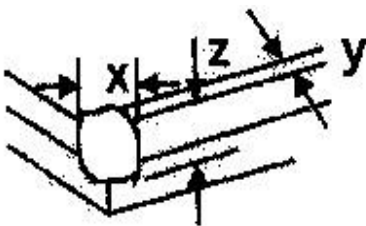
NO	Item	Criterion	AQL																		
05	Scratches	Follow NO.3 LCD black spots, white spots, contamination																			
06	Chipped glass	<p>Symbols Define: x: Chip length y: Chip width z: Chip thickness k: Seal width t: Glass thickness a: LCD side length L: Electrode pad length:</p> <p>6.1 General glass chip : 6.1.1 Chip on panel surface and crack between panels:</p>  <table border="1" data-bbox="459 958 1369 1205"> <thead> <tr> <th>z: Chip thickness</th> <th>y: Chip width</th> <th>x: Chip length</th> </tr> </thead> <tbody> <tr> <td>$z \leq 1/2t$</td> <td>Not over viewing area</td> <td>$x \leq 1/8a$</td> </tr> <tr> <td>$1/2t < z \leq 2t$</td> <td>Not exceed 1/3k</td> <td>$x \leq 1/8a$</td> </tr> </tbody> </table> <p>⊙If there are 2 or more chips, x is total length of each chip.</p> <p>6.1.2 Corner crack:</p>  <table border="1" data-bbox="459 1684 1369 1930"> <thead> <tr> <th>z: Chip thickness</th> <th>y: Chip width</th> <th>x: Chip length</th> </tr> </thead> <tbody> <tr> <td>$z \leq 1/2t$</td> <td>Not over viewing area</td> <td>$x \leq 1/8a$</td> </tr> <tr> <td>$1/2t < z \leq 2t$</td> <td>Not exceed 1/3k</td> <td>$x \leq 1/8a$</td> </tr> </tbody> </table> <p>⊙If there are 2 or more chips, x is the total length of each chip.</p>	z: Chip thickness	y: Chip width	x: Chip length	$z \leq 1/2t$	Not over viewing area	$x \leq 1/8a$	$1/2t < z \leq 2t$	Not exceed 1/3k	$x \leq 1/8a$	z: Chip thickness	y: Chip width	x: Chip length	$z \leq 1/2t$	Not over viewing area	$x \leq 1/8a$	$1/2t < z \leq 2t$	Not exceed 1/3k	$x \leq 1/8a$	2.5
z: Chip thickness	y: Chip width	x: Chip length																			
$z \leq 1/2t$	Not over viewing area	$x \leq 1/8a$																			
$1/2t < z \leq 2t$	Not exceed 1/3k	$x \leq 1/8a$																			
z: Chip thickness	y: Chip width	x: Chip length																			
$z \leq 1/2t$	Not over viewing area	$x \leq 1/8a$																			
$1/2t < z \leq 2t$	Not exceed 1/3k	$x \leq 1/8a$																			

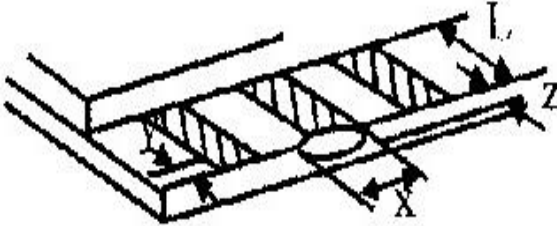
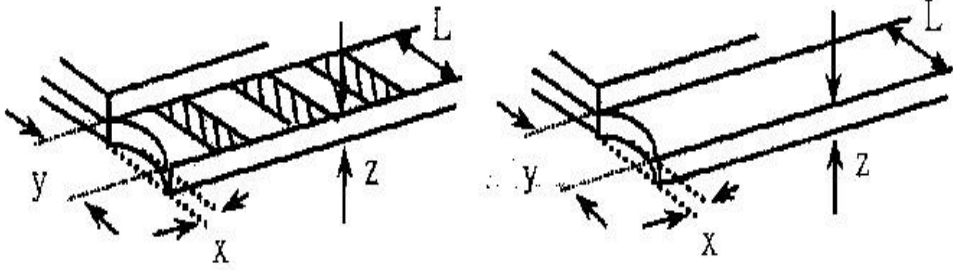
NO	Item	Criterion	AQL																
06	Glass crack	<p>Symbols :</p> <p>x: Chip length y: Chip width z: Chip thickness</p> <p>k: Seal width t: Glass thickness a: LCD side length</p> <p>L: Electrode pad length</p> <p>6.2 Protrusion over terminal :</p> <p>6.2.1 Chip on electrode pad :</p>  <table border="1" data-bbox="379 835 1300 981"> <thead> <tr> <th>y: Chip width</th> <th>x: Chip length</th> <th>z: Chip thickness</th> </tr> </thead> <tbody> <tr> <td>$y \leq 0.5\text{mm}$</td> <td>$x \leq 1/8a$</td> <td>$0 < z \leq t$</td> </tr> </tbody> </table> <p>6.2.2 Non-conductive portion:</p>  <table border="1" data-bbox="450 1361 1276 1518"> <thead> <tr> <th>y: Chip width</th> <th>x: Chip length</th> <th>z: Chip thickness</th> </tr> </thead> <tbody> <tr> <td>$y \leq L$</td> <td>$x \leq 1/8a$</td> <td>$0 < z \leq t$</td> </tr> </tbody> </table> <p>⊙If the chipped area touches the ITO terminal, over 2/3 of the ITO must remain and be inspected according to electrode terminal specifications.</p> <p>⊙If the product will be heat sealed by the customer, the alignment mark not be damaged.</p> <p>6.2.3 Substrate protuberance and internal crack.</p> <table border="1" data-bbox="788 1917 1348 2060"> <thead> <tr> <th>y: width</th> <th>x: length</th> </tr> </thead> <tbody> <tr> <td>$y \leq 1/3L$</td> <td>$x \leq a$</td> </tr> </tbody> </table>	y: Chip width	x: Chip length	z: Chip thickness	$y \leq 0.5\text{mm}$	$x \leq 1/8a$	$0 < z \leq t$	y: Chip width	x: Chip length	z: Chip thickness	$y \leq L$	$x \leq 1/8a$	$0 < z \leq t$	y: width	x: length	$y \leq 1/3L$	$x \leq a$	2.5
y: Chip width	x: Chip length	z: Chip thickness																	
$y \leq 0.5\text{mm}$	$x \leq 1/8a$	$0 < z \leq t$																	
y: Chip width	x: Chip length	z: Chip thickness																	
$y \leq L$	$x \leq 1/8a$	$0 < z \leq t$																	
y: width	x: length																		
$y \leq 1/3L$	$x \leq a$																		

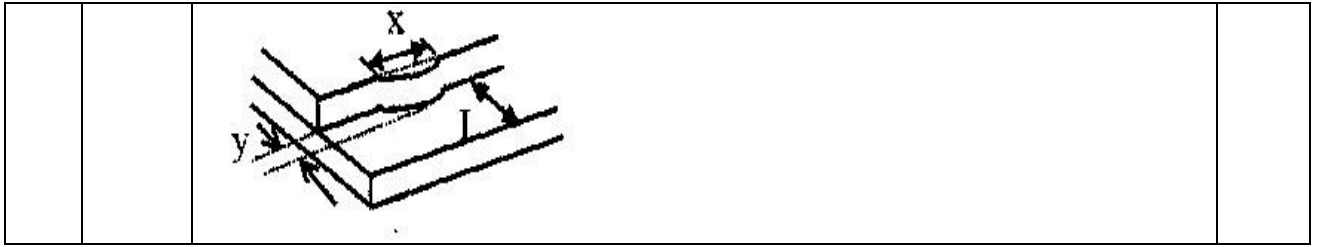

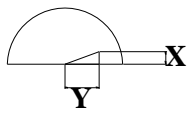
NO	Item	Criterion	AQL
07	Cracked glass	The LCD with extensive crack is not acceptable.	2.5
08	Backlight elements	8.1 Illumination source flickers when lit. 8.2 Spots or scratched that appear when lit must be judged. Using LCD spot, lines and contamination standards. 8.3 Backlight doesn't light or color wrong.	0.65 2.5 0.65
09	Bezel	9.1 Bezel may not have rust, be deformed or have fingerprints, stains or other contamination. 9.2 Bezel must comply with job specifications.	2.5 0.65
10	PCB、COB	10.1 COB seal may not have pinholes larger than 0.2mm or contamination. 10.2 COB seal surface may not have pinholes through to the IC. 10.3 The height of the COB should not exceed the height indicated in the assembly diagram. 10.4 There may not be more than 2mm of sealant outside the seal area on the PCB. And there should be no more than three places. 10.5 No oxidation or contamination PCB terminals. 10.6 Parts on PCB must be the same as on the production characteristic chart. There should be no wrong parts, missing parts or excess parts. 10.7 The jumper on the PCB should conform to the product characteristic chart. 10.8 If solder gets on bezel tab pads, LED pad, zebra pad or screw hold pad, make sure it is smoothed down. 10.9 The Scraping testing standard for Copper Coating of PCB  $X * Y \leq 2\text{mm}^2$	2.5 2.5 0.65 2.5 2.5 0.65 0.65 2.5 2.5
11	Soldering	11.1 No un-melted solder paste may be present on the PCB. 11.2 No cold solder joints, missing solder connections, oxidation or icicle. 11.3 No residue or solder balls on PCB. 11.4 No short circuits in components on PCB.	2.5 2.5 2.5 0.65

NO	Item	Criterion	AQL
12	General appearance	12.1 No oxidation, contamination, curves or, bends on interface Pin (OLB) of TCP.	2.5
		12.2 No cracks on interface pin (OLB) of TCP.	0.65
		12.3 No contamination, solder residue or solder balls on product.	2.5
		12.4 The IC on the TCP may not be damaged, circuits.	2.5
		12.5 The uppermost edge of the protective strip on the interface pin must be present or look as if it cause the interface pin to sever.	2.5
		12.6 The residual rosin or tin oil of soldering (component or chip component) is not burned into brown or black color.	2.5
		12.7 Sealant on top of the ITO circuit has not hardened.	0.65
		12.8 Pin type must match type in specification sheet.	0.65
		12.9 LCD pin loose or missing pins.	0.65
		12.10 Product packaging must the same as specified on packaging specification sheet.	0.65
		12.11 Product dimension and structure must conform to product specification sheet.	0.65
		12.12 Visual defect outside of VA is not considered to be rejection.	

10.Precautions in use of LCD Modules

- (1) Avoid applying excessive shocks to the module or making any alterations or modifications to it.
- (2) Don't make extra holes on the printed circuit board, modify its shape or change the components of LCD module.
- (3) Don't disassemble the LCM.
- (4) Don't operate it above the absolute maximum rating.
- (5) Don't drop, bend or twist LCM.
- (6) Soldering: only to the I/O terminals.
- (7) Storage: please storage in anti-static electricity container and clean environment.
- (8) DISPLAY have the right to change the passive components, including R3,R6 & backlight adjust resistors. (Resistors, capacitors and other passive components will have different appearance and color caused by the different supplier.)
- (9) DISPLAY have the right to change the PCB Rev. (In order to satisfy the supplying stability, management optimization and the best product performance...etc, under the premise of not affecting the electrical characteristics and external dimensions, DISPLAY have the right to modify the version.)
- (10) To ensure the stability of the display screen, please apply screen saver after showing 30 mins of fixed display content.
- (11) Please heat up a little the tape sticking on the components when removing it; otherwise the components might be damaged.

11. Material List of Components for RoHs

1. DISPLAY Elektronik GmbH. hereby declares that all of or part of products (with the mark “#”in code), including, but not limited to, the LCM, accessories or packages, manufactured and/or delivered to your company (including your subsidiaries and affiliated company) directly or indirectly by our company (including our subsidiaries or affiliated companies) do not intentionally contain any of the substances listed in all applicable EU directives and regulations, including the following substances.

Exhibit A : The Harmful Material List

Material	Cd	Pb	Hg	Cr6+	PBB	PBDE	DEHP	BBP	DBP	DIBP
Limited Value	100 ppm	1000 ppm	1000 ppm	1000 ppm	1000 ppm	1000 ppm	1000 ppm	1000 ppm	1000 ppm	1000 ppm
Above limited value is set up according to RoHS.										

2.Process for RoHS requirement : (only for RoHS inspection)

(1) Use the Sn/Ag/Cu soldering surface ; the surface of Pb-free solder is rougher than we used before.

(2) Heat-resistance temp. :

Reflow : 250°C,30 seconds Max. ;

Connector soldering wave or hand soldering : 320°C, 10 seconds max.

(3) Temp. curve of reflow, max. Temp. : 235±5°C ;

Recommended customer’s soldering temp. of connector : 280°C, 3 seconds.

12.Recommendable Storage

1. Place the panel or module in the temperature $25^{\circ}\text{C}\pm 5^{\circ}\text{C}$ and the humidity below 65% RH
2. Do not place the module near organics solvents or corrosive gases.
3. Do not crush, shake, or jolt the module.