

240 – 960 MHz SoC OOK/(G)FSK Transmitter

Features

- High-Performance RISC Microcontroller Core
 - All Single-Cycle Instructions Except Branches
 - Up to 8 MHz Clock
 - Multiple Interruption Supported
 - 32 Bytes EEPROM / 64 Bytes SRAM / 1024 Words Flash
- High-Performance OOK Transmitter
 - All Features Programmable on the RFPDK
 - CMT2180AW: 240 to 480 MHz, OOK Modulation
 - CMT2189AW: 240 to 960 MHz, OOK/(G)FSK Modulation
 - Symbol Rate: up to 30 ksp/s for OOK, 100 ksp/s for (G)FSK
 - Configurable Single-Ended or Differential PA Output
 - Output Power: -10 to +13 dBm
- Supply Voltage: 2.3 to 3.6 V
- 1-pin Crystal
- FCC / ETSI Compliant
- RoHS Compliant
- 14-pin SOP Package

Description

The CMT2180/89AW is a fully integrated, highly flexible, high performance, SoC OOK/G(FSK) transmitter with an embedded RISC microcontroller core for various 240 to 960 MHz wireless applications. It is part of the CMOSTEK NextGenRF™ family, which includes a complete line of transmitters, receivers and transceivers. The device includes a 1024 words flash for programming the user's application, supports up to 4 push buttons to implement the user defined functions. All the device features (such as frequency, output power, WDT, Security and etc.) and programs can be burned into the device using the CMOSTEK USB Programmer and RFPDK. Alternatively, in stock products of 433.92/868.35 MHz are available for immediate demands with no need of extra programming. The CMT2180/89AW uses a 1-pin crystal oscillator circuit with the required crystal load capacitance integrated on-chip to minimize the BOM counts. The device can deliver up to +13 dBm output power and the PA output can be either single-ended or differential. The device operates from 2.3 V to 3.6 V. Its low power design enables superior operation life for battery powered application. The CMT2180/89AW transmitter together with CMOSTEK NextGenRF™ receiver enables a highly flexible, low cost RF link.

Applications

- Remote Keyless Entry (RKE)
- Garage and gate door openers
- Home/Building Automation and Security
- Industrial Monitoring and Controls
- Remote Lighting Control
- Wireless Alarm and Security Systems
- Consumer Electronics Applications

Ordering Information

Part Number	Frequency	Package	MOQ
CMT2180AW-ESR	433.92 MHz	SOP14	2,500 pcs
CMT2189AW-ESR	868.35 MHz	SOP14	2,500 pcs

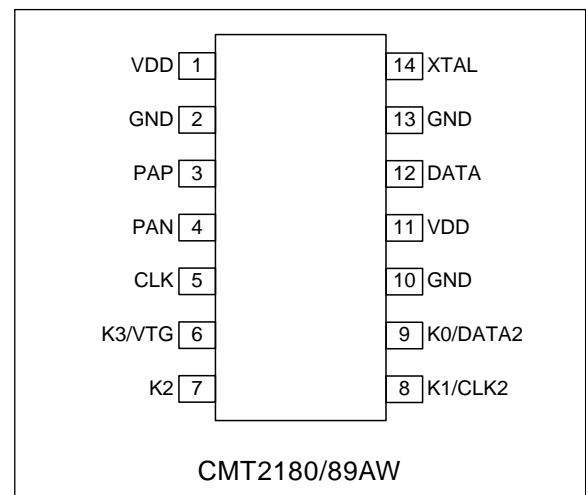

Typical Application

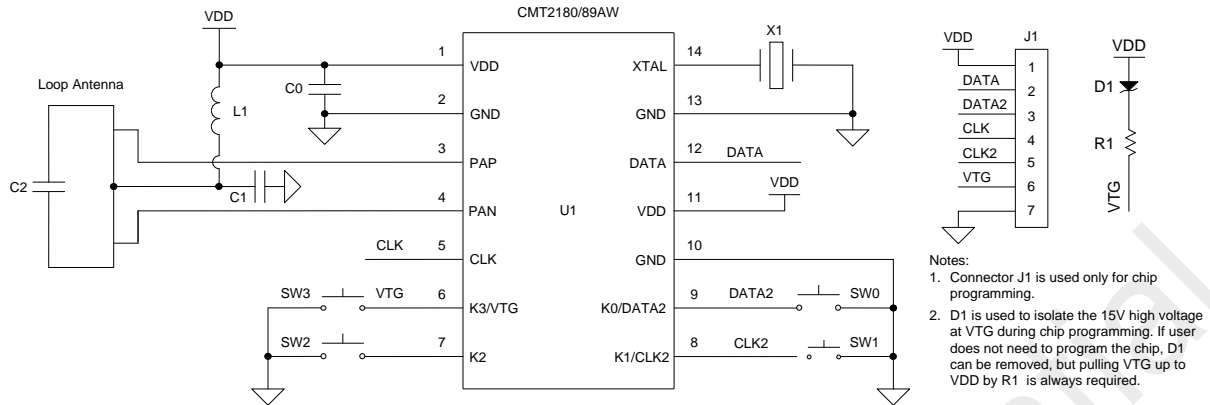

Figure 1. CMT2180/89AW Typical Application with Differential PA Output

Table 1. BOM of 433.92 MHz Application with Differential PA Output

Designator	Descriptions	Value	Unit	Manufacturer
U1	CMT2180/89AW, 240 – 960 MHz SoC OOK/(G)FSK transmitter	-	-	CMOSTEK
X1	±20 ppm, SMD32*25 mm crystal	26	MHz	EPSON
SW[3:0]	Push buttons	-	-	
D1	MBR0520LT1, SOD123	-	-	IR
R1	±5%, 0402	10k	Ω	
C0	±20%, 0402 X7R, 25 V	0.1	uF	Murata GRM15
C1	±0.25 pF, 0402 NP0, 50 V	2.2	pF	Murata GRM15
C2	±0.25 pF, 0402 NP0, 50 V	2.2	pF	Murata GRM15
L1	±5%, 0603 multi-layer chip inductor	180	nH	Murata LQG18

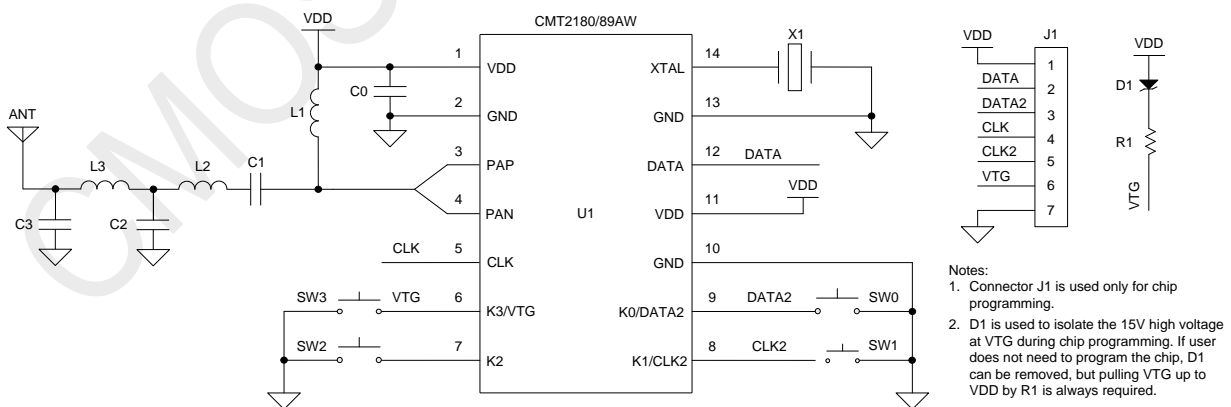

Figure 2. CMT2180/89AW Typical Application with Single-ended PA Output

Table 2. BOM of 433.92 MHz Application with Single-ended PA Output

Designator	Descriptions	Value	Unit	Manufacturer
U1	CMT2180/89AW, 240 – 960 MHz SoC OOK/(G)FSK transmitter	-	-	CMOSTEK
X1	±20 ppm, SMD32*25 mm crystal	26	MHz	EPSON
SW[3:0]	Push buttons	-	-	
D1	MBR0520LT1, SOD123	-	-	IR
R1	±5%, 0402	10k	Ω	
C0	±20%, 0402 X7R, 25 V	0.1	uF	Murata GRM15
C1	±5%, 0402 NP0, 50 V	68	pF	Murata GRM15
C2	±5%, 0402 NP0, 50 V	15	pF	Murata GRM15
C3	±5%, 0402 NP0, 50 V	15	pF	Murata GRM15
L1	±5%, 0603 multi-layer chip inductor	180	nH	Murata LQG18
L2	±5%, 0603 multi-layer chip inductor	36	nH	Murata LQG18
L3	±5%, 0603 multi-layer chip inductor	18	nH	Murata LQG18

Table 3. CMT2180/89AW Pin Descriptions

Pin Number	Name	I/O	Descriptions
1	VDD	I	Power supply input
2	GND	I	Ground
3	PAP	O	The differential power amplifier output, when using as singled-ended output, PAN/PAP should be connected together before connect to the matching network
4	PAN	O	
5	CLK	I	Clock1 for the chip programming, internally pulled up to VDD
6	K3/VTG	I	Push button key 3 or voltage for the chip programming
7	K2	I	Push button key 2
8	K1/CLK2	I	Push button key 1 or clock2 for the chip programming
9	K0/DATA2	IO	Push button key 0 or data2 for the chip programming
10	GND	I	Ground
11	VDD	I	Power supply input
12	DATA	IO	Data1 for the chip programming Pulled up internally to VDD when configured as Transmission Enabled by DATA Pin Rising Edge and used as input pin
13	GND	I	Ground
14	XTAL	I	26 MHz single-ended crystal oscillator input or external 26 MHz reference clock input

Package Outline

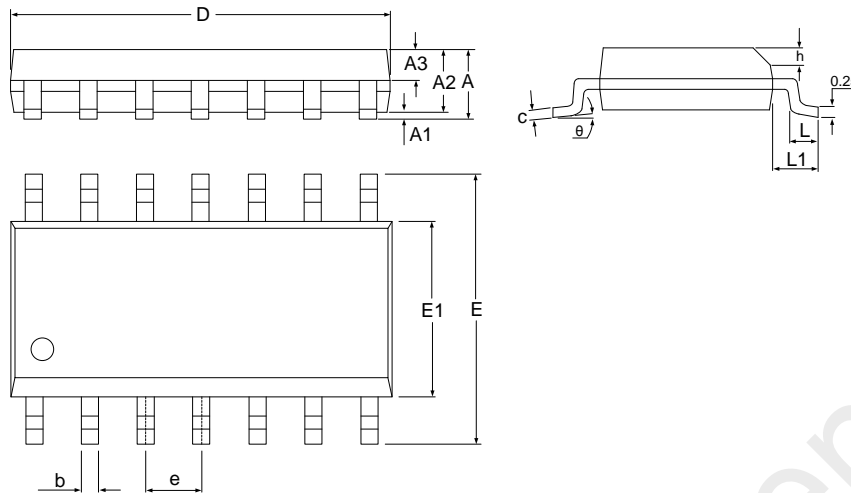

Figure 3. 14-Pin SOP Package

Table 4. 14-Pin SOP Package Dimensions

Symbol	Size (millimeters)		
	Min	Typ	Max
A	-	-	1.75
A1	0.05	-	0.225
A2	1.30	1.40	1.50
A3	0.60	0.65	0.70
b	0.39	-	0.48
C	0.21	-	0.26
D	8.45	8.65	8.85
E	5.80	6.00	6.20
E1	3.70	3.90	4.10
e	1.27 BSC		
h	0.25	-	0.50
L	0.30	-	0.60
L1	1.05 BSC		
θ	0	-	8°

Copyright. CMOSTEK Microelectronics Co., Ltd. All rights are reserved.

The information furnished by CMOSTEK is believed to be accurate and reliable. However, no responsibility is assumed for inaccuracies and specifications within this document are subject to change without notice. The material contained herein is the exclusive property of CMOSTEK and shall not be distributed, reproduced, or disclosed in whole or in part without prior written permission of CMOSTEK. CMOSTEK products are not authorized for use as critical components in life support devices or systems without express written approval of CMOSTEK. The CMOSTEK logo is a registered trademark of CMOSTEK Microelectronics Co., Ltd. All other names are the property of their respective owners.