

Logic relays

Product group picture

6



Logic relays

Table of contents

Logic relays

System overview	6/3
Ordering details - Stand alone logic relays	6/5
Ordering details - Expandable logic relays	6/6
Ordering details - Accessories	6/7
Ordering details - Display systems	6/8
Technical data	6/9
Dimensional drawings	6/23

Logic relays

System overview

Concept

CL range logic relays are suitable for small and medium-sized control tasks and are able to substitute logic wiring in a quick and simple manner.

They can be used for applications in control as well as for timing functions, e.g.

- in buildings, lighting systems, air-conditioning systems, general control functions,
- in small machines and systems or
- as stand-alone control module for small applications.

Steps to the application of CL range

- CL range can be used easily, rapidly and comfortably without any time-consuming planning and programming.
- The user can discover the advantages and the benefit of these logic relays in no time at all.
- CL range provides for the control statements according to a simple circuit diagram.
- Setup, storage, simulation and documentation are performed using the compact and user-friendly CL-SOFT software (CL-LAS.PS002).

Software characteristics (CL-SOFT)

- Display on a PC monitor according to IEC, ANSI
- Different languages to choose from
- Easy installation on all Microsoft Windows™ operating systems

Logic links instead of wiring

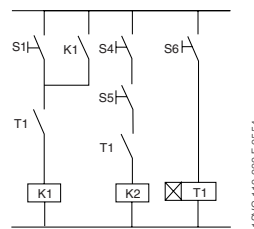

Documentation (download from the internet)

Logic relay manual: 1SVC440795M0100

Remote display manual: 1SVC440795M2100

Display system manual: 1SVC440795M1100

6

Technical data overview

Logic relays

- 8 or 12 digital inputs
- 4 or 6 digital relay outputs
- optionally with 4 or 8 transistor outputs
- 128 rungs
- 3 contacts as n/o or n/c contacts in series plus 1 coil per rung
- optionally with 2 or 4 analog inputs (not 100-240 V AC version)
- power flow display for checking the circuit diagram (devices with display)
- expansions for local or remote level
- enclosure color RAL 7035
- DIN rail mounting

Remote display

- Remote display up to a distance of 5 m
- Illustration of text and status displays
- Remote adjustment via keypad
- Front panel mounting

Display system

- useable as compact HMI logic relay
- fully graphic, backlit display module
- 12 digital inputs
- 4 digital relay outputs
- optionally with 4 transistor outputs
- 256 rungs
- 4 contacts as n/o or n/c contacts in series plus 1 coil per rung
- optionally with 4 analog inputs (not 100-240 V AC version)
- networking-compatible via CL-NET
- front panel mounting
- expansion for local

Software

- 16 timing relays 0.01-99:59 h
- 16 counting relays for up-, down counting
- 8 weekly timer, 8 annual timers
- 16 analog value comparators
- 16 freely editable display texts
- 32 markers or auxiliary relays

Logic relays

System overview

Logic relays

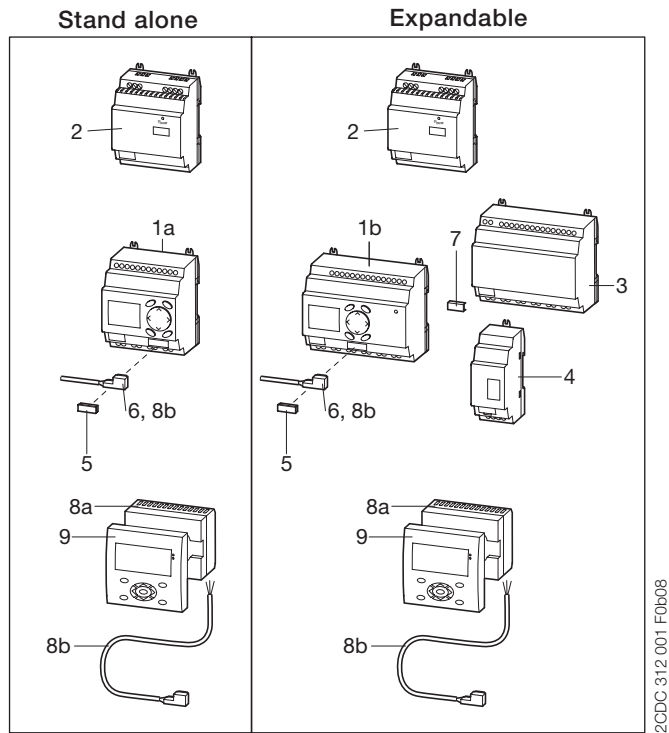

- 1a Logic relay CL-LS..
- 1b Expandable logic relay CL-LM..
- 2 Power supply CP-D...
- 3 I/O expansion CL-LER..., CL-LET.. for logic relays CL-LM..
- 4 Coupler unit CL-LEC.. for remote expansion of logic relays CL-LM..
- 5 Memory module CL-LAS.MD003 for logic relays CL-LS.., CL-LM..
- 6 Connecting cable CL-LAS.TK001, CL-LAS.TK002 to connect PC CL-LINK plug CL-LAS.TK011 to connect expansion to logic relays CL-LM..
- 7 CL-LINK plug CL-LAS.TK011
- 8a Remote display connection module CL-LDC.S..
- 8b Connecting cable CL-LAD.TK007 to connect a remote displays to a logic relay
- 9 Display module CL-LDD..

Expansion of logic relays*

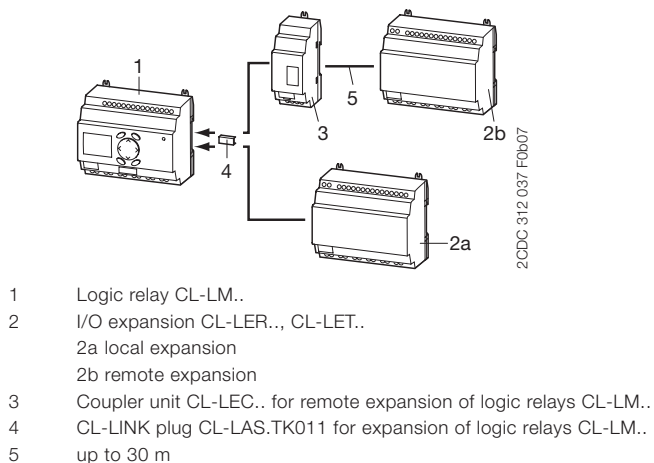

* max. 1 expansion per logic relay

Display system → Compact HMI logic relay

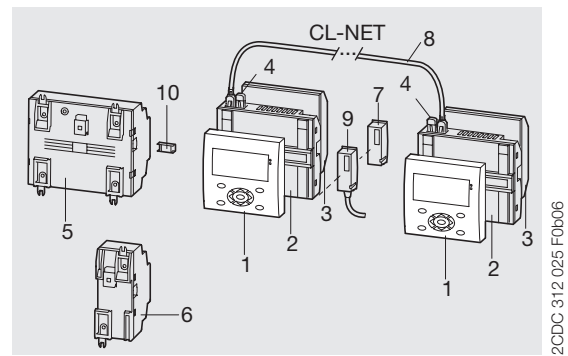

- 1 Display module CL-LDD..
- 2 Display base module CL-LDC.LN..
- 3 Display I/O module CL-LDR.., CL-LDT..
- 4 Termination resistor CL-LAD.TK009
- 5 I/O expansion CL-LER..., CL-LET..
- 6 Coupler unit CL-LEC.. for remote expansion
- 7 Memory module CL-LAD.MD004 for display base module
- 8 Connecting cable CL-LAD.TK002, CL-LAD.TK003, CL-LAD.TK004
- 9 Connecting cable CL-LAD.TK001, CL-LAD.TK011 to connect PC
- 10 CL-LINK plug CL-LAS.TK011 for expansion of logic relays CL-LM.. e.g. door of switchgear cabinet

Stand alone with I/O module

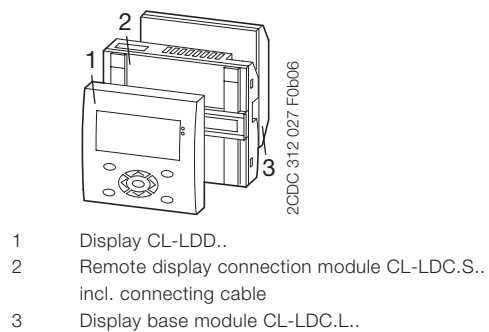

- 1 Display CL-LDD..
- 2 Remote display connection module CL-LDC.S.. incl. connecting cable
- 3 Display base module CL-LDC.L..

Communication via CL-NET

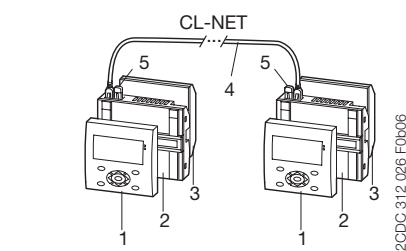

- 1 Display CL-LDD..
- 2 Display base module CL-LDC.LN.. for CL-NET
- 3 Display I/O module CL-LDR.., CL-LDT..
- 4 Connecting cable CL-LAD.TK002, CL-LAD.TK003, CL-LAD.TK004
- 5 Termination resistor CL-LAD.TK009

Logic relays

Ordering details - Stand alone logic relays



CL-LSR

2CDC281 034 F0006



CL-LST

2CDC281 033 F0006

Ordering details - Logic relays stand alone

Rated operational voltage	Display + Keypad	Timer	Input / Output	Type	Order code	Price 1 pc	Weight (1 pc) kg (lb)
24 V AC	■	■	8 inputs / 4 relay outputs	CL-LSR.C12AC1	1SVR440712R0300		0.20 (0.44)
				CL-LSR.CX12AC1	1SVR440712R0200		
100-240 V AC	■	■		CL-LSR.12AC2	1SVR440713R0100		
				CL-LSR.C12AC2	1SVR440713R0300		
12 V DC	■	■		CL-LSR.CX12AC2	1SVR440713R0200		
				CL-LSR.C12DC1	1SVR440710R0300		
24 V DC	■	■		CL-LSR.CX12DC1	1SVR440710R0200		
				CL-LSR.12DC2	1SVR440711R0100		
24 V DC	■	■	CL-LSR.C12DC2	1SVR440711R0300			
			CL-LSR.CX12DC2	1SVR440711R0200			
24 V DC	■	■	8 inputs / 4 transistor outputs	CL-LST.C12DC2	1SVR440711R1300		
				CL-LST.CX12DC2	1SVR440711R1200		

6

Ordering details - Display modules

Rated operational voltage	Description	Type	Order code	Price 1 pc	Weight (1 pc) kg (lb)
-	Graphic display 132 x 64 pixel	CL-LDD.XK	1SVR440839R4500		0.14 (0.30)
-	Graphic display 132 x 64 pixel, with keypad	CL-LDD.K	1SVR440839R4400		0.13 (0.29)
24 V DC	Module to displace the display from the logic relay, incl. connecting cable CL-LAD.	CL-LDC.SDC2	1SVR440841R0000		0.16 (0.36)
100-240 V AC	TK007, 5m, length adaptable	CL-LDC.SAC2	1SVR440843R0000		0.16 (0.36)



CL-LDD.K

2CDC281 028 F0006



CL-LDC.S..

2CDC281 017 F0007

Logic relays

Ordering details - Expandable logic relays



CL-LMR

2CDC 311 038 F0006

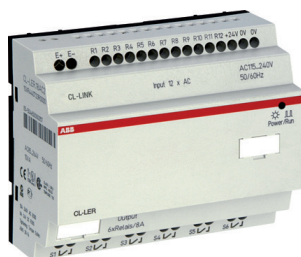

CL-LER

2CDC 311 037 F0007



CL-LEC

2CDC 311 038 F0006

Ordering details - Logic relays expandable

Rated operational voltage	Display + Keypad	Timer	Input / Output	Type	Order code	Price 1 pc	Weight (1 pc) kg (lb)
24 V AC	■	■	12 inputs / 6 relay outputs	CL-LMR.C18AC1	1SVR440722R0300		0.36 (0.79)
100-240 V AC	■	■		CL-LMR.CX18AC1	1SVR440722R0200		
				CL-LMR.C18AC2	1SVR440723R0300		
12 V DC	■	■		CL-LMR.CX18AC2	1SVR440723R0200		
				CL-LMR.C18DC1	1SVR440720R0300		
24 V DC	■	■		CL-LMR.CX18DC1	1SVR440720R0200		
			CL-LMR.C18DC2	1SVR440721R0300			
24 V DC	■	■	12 inputs, 8 transistor outputs	CL-LMR.CX18DC2	1SVR440721R0200		0.36 (0.79)
				CL-LMT.C20DC2	1SVR440721R1300		
24 V DC	■	■	CL-LMT.CX20DC2	1SVR440721R1200			

Ordering details - Expansions

Rated operational voltage	Description	Type	Order code	Price 1 pc	Weight (1 pc) kg (lb)
-	2 relay outputs	CL-LER.20	1SVR440709R5000		0.07 (0.15)
100-240 V AC	12 inputs, 6 relay outputs	CL-LER.18AC2	1SVR440723R0000		0.26 (0.57)
24 V DC		CL-LER.18DC2	1SVR440721R0000		0.22 (0.49)
24 V DC	12 inputs, 8 transistor outputs	CL-LET.20DC2	1SVR440721R1000		0.21 (0.46)
-	Coupler unit for remote expansion with a distance of up to 30 m	CL-LEC.CI000	1SVR440709R0000		0.07 (0.15)

Logic relays

Ordering details - Accessories



CL-LAS.PS002

2CDC 311 012 F0007



CL-LAS.TK001

2CDC 311 014 F0007



CL-LAS.MD003

2CDC 311 013 F0007

Ordering details - CL-LA...

Description	Type	Order code	Price	Weight
			1 pc	(1 pc) kg (lb)
Software for programming and control of CL range devices. Installation CD-ROM for Microsoft Windows™.	CL-LAS.PS002	1SVR440799R8000		0.10 (0.21)
Memory module for logic relays Memory size: 32 kB	CL-LAS.MD003	1SVR440799R7000		0.02 (0.04)
Cable with serial interface to connect PC and logic relay, length: 2 m	CL-LAS.TK001	1SVR440799R6000		0.10 (0.22)
Cable with USB interface to connect PC and logic relay, length: 2 m	CL-LAS.TK002	1SVR440799R6100		0.06 (0.13)
Cable for point-to-point connection of remote-display connection module and logic relay, length: 5m, adaptable	CL-LAD.TK007	1SVR440899R6600		0.20 (0.44)
Fixing brackets for screw mounting of logic relay, expansion, display base module	CL-LAS.FD001	1SVR440799R5000		0.01 (0.01)
Spare plug (CL-LINK) for connection of logic relay to expansion	CL-LAS.TK011	1SVR440799R5100		0.10 (0.22)

Ordering details - Power supply units

Technical data see chapter "Primary switch mode power supplies"

Description	Type	Order code	Price	Weight
			1 pc	(1 pc) kg (lb)
Primary switch mode power supplies, Rated input voltage: 100-240 V AC Rated output voltage/current: 24 V DC / 0.42 A	CP-D 24/0.42	1SVR427041R0000		0.06 (0.13)
Primary switch mode power supplies, Rated input voltage: 100-240 V AC Rated output voltage/current: 24 V DC / 1.3 A	CP-D 24/1.3	1SVR427043R0100		0.19 (0.41)

Logic relays

Ordering details - Display systems



CL-LDD.K

2CDC 311 028 F0006



CL-LDC.LN..

2CDC 311 031 F0006



CL-LAD.MD004

2CDC 311 018 F0007



CL-LAD.TK001

2CDC 311 019 F0007



CL-LAD.TK002

2CDC 311 020 F0006

Ordering details - Display systems

Rated operational voltage	Description	Type	Order code	Price 1 pc	Weight (1 pc) kg (lb)
-	Display module Graphic display 132 x 64 pixel	CL-LDD.XK	1SVR440839R4500		0.14 (0.30)
-	Display module Graphic display 132 x 64 pixel, with keypad	CL-LDD.K	1SVR440839R4400		0.13 (0.29)
24 V DC	Display base module CPU / power supply	CL-LDC.LDC2	1SVR440821R0000		0.16 (0.36)
100-240 V AC	Display base module CPU / power supply, networking-compatible (CL-NET)	CL-LDC.LAC2	1SVR440823R0000		0.17 (0.38)
24 V DC	Display I/O module 12 inputs, 4 relay outputs	CL-LDR.16AC2	1SVR440853R0000		0.17 (0.38)
100-240 V AC	Display I/O module 12 inputs, 4 relay outputs, 1 analog output	CL-LDR.16DC2	1SVR440851R0000		0.17 (0.38)
24 V DC	Display I/O module 12 inputs, 4 transistor outputs	CL-LDR.17DC2	1SVR440851R2000		0.17 (0.38)
24 V DC	Display I/O module 12 inputs, 4 transistor outputs, 1 analog output	CL-LDT.16DC2	1SVR440851R1000		0.14 (0.30)
24 V DC	Display I/O module 12 inputs, 4 transistor outputs, 1 analog output	CL-LDT.17DC2	1SVR440851R3000		0.14 (0.30)

Ordering details - CL-LAD...

Description	Type	Order code	Price 1 pc	Weight (1 pc) kg (lb)
Memory module for display base modules Memory size: 256 kB	CL-LAD.MD004	1SVR440899R7000		0.02 (0.03)
Cable with serial interface to connect PC and display base module	CL-LAD.TK001	1SVR440899R6000		0.11 (0.23)
Cable with USB interface to connect PC and display base module	CL-LAD.TK011	1SVR440899R6700		
Network cable (CL-NET) to connect 2 display base modules, length: 0.3 m	CL-LAD.TK002	1SVR440899R6100		0.05 (0.12)
Network cable (CL-NET) to connect 2 display base modules, length: 0.8 m	CL-LAD.TK003	1SVR440899R6200		0.07 (0.14)
Network cable (CL-NET) to connect 2 display base modules, length: 1.5 m	CL-LAD.TK004	1SVR440899R6300		0.08 (0.18)
Cable for point-to-point connection of remote display connection modules and display base module, length: 5m, adaptable	CL-LAD.TK005	1SVR440899R6400		0.20 (0.44)
Termination resistor, content: 2 pieces	CL-LAD.TK009	1SVR440899R6900		0.01 (0.02)
Protective cover, transparent, for harsh environmental conditions and application in the food industry	CL-LAD.FD001	1SVR440899R1000		0.03 (0.07)
Protective cover, transparent and sealable	CL-LAD.FD011	1SVR440899R2000		0.03 (0.07)
Assembly tool for mounting of display modules	CL-LAD.FD002	1SVR440899R3000		

Logic relays

Technical data

Data at $T_a = 25\text{ °C}$ and rated values, if nothing else indicated.

Type	CL-LSR.C...12DC1	CL-LSR...12DC2 CL-LST.C...12DC2	CL-LSR.C...12AC1	CL-LSR...12AC2
Input circuit - supply circuit				
Rated operational voltage U_o	12 V DC	24 V DC	24 V AC	100-240 V AC
Rated operational voltage tolerance	-15...+30 %	-15...+20 %	-15...+10 %	-
Operational voltage range	10.2-15.6 V DC	20.4-28.8 V DC	20.4-26.4 V AC	85-264 V AC
Rated frequency	0 Hz	-	50/60 Hz	-
Rated frequency tolerance	-	-	±5 %	-
Residual ripple	≤ 5 %	-	-	-
Input current	at 12 V DC typ. 140 mA	-	-	-
	at 24 V DC -	typ. 80 mA	-	-
	at 24 V AC -	-	typ. 200 mA	-
	at 115/120 V AC (60 Hz) -	-	-	typ. 40 mA
	at 230/240 V AC (50 Hz) -	-	-	typ. 20 mA
Power failure buffering (IEC/EN 61131-2)	10 ms	-	20 ms	-
Power dissipation	at 12 V DC typ. 2 W	-	-	-
	at 24 V DC -	typ. 2 W	-	-
	at 24 V AC -	-	typ. 5 VA	-
	at 115/120 V AC -	-	-	typ. 5 VA
	at 230/240 V AC -	-	-	typ. 5 VA
Type	CL-LMR.C...18DC1	CL-LMR.C...18DC2 CL-LMT.C...20DC2	CL-LMR.C...18AC1	CL-LMR.C...18AC2
Input circuit - supply circuit				
Rated operational voltage U_o	12 V DC	24 V DC	24 V AC	100-240 V AC
Rated operational voltage tolerance	-15...+30 %	-15...+20 %	-15...+10 %	-
Operational voltage range	10.2-15.6 V DC	20.4-28.8 V DC	20.4-26.4 V AC	85-264 V AC
Rated frequency	0 Hz	-	50/60 Hz	-
Rated frequency tolerance	-	-	±5 %	-
Residual ripple	≤ 5 %	-	-	-
Input current	at 12 V DC typ. 200 mA	-	-	-
	at 24 V DC -	typ. 140 mA	-	-
	at 24 V AC -	-	typ. 300 mA	-
	at 115/120 V AC (60 Hz) -	-	-	typ. 70 mA
	at 230/240 V AC (50 Hz) -	-	-	typ. 35 mA
Power failure buffering (IEC/EN 61131-2)	10 ms	-	20 ms	-
Power dissipation	at 12 V DC typ. 3.5 W	-	-	-
	at 24 V DC -	typ. 3.5 W	-	-
	at 24 V AC -	-	typ. 7 VA	-
	at 115/120 V AC -	-	-	typ. 10 VA
	at 230/240 V AC -	-	-	typ. 10 VA
Type	CL-LER.18DC2 CL-LET.20DC2	CL-LER.18AC2		
Input circuit - supply circuit				
Rated operational voltage U_o	24 V DC	100-240 V AC		
Rated operational voltage tolerance	-15...+20 %	-15...+10 %		
Operational voltage range	20.4-28.8 V DC	85-264 V AC		
Rated frequency	0 Hz	50/60 Hz		
Rated frequency tolerance	-	±5 %		
Residual ripple	≤ 5 %	-		
Input current	at 24 V DC typ. 140 mA	-		
	at 115/120 V AC (60 Hz) -	typ. 70 mA		
	at 230/240 V AC (50 Hz) -	typ. 35 mA		
Power failure buffering (IEC/EN 61131-2)	10 ms	20 ms		
Power dissipation	at 24 V DC typ. 3.4 W	-		
	at 115/120 V AC -	typ. 10 VA		
	at 230/240 V AC -	typ. 10 VA		

Logic relays

Technical data

Data at $T_a = 25\text{ °C}$ and rated values, if nothing else indicated.

Type		CL-LSR.C...12DC1	CL-LSR...12DC2 CL-LST.C...12DC2	CL-LSR.C...12AC1	CL-LSR.C...12AC2
Input circuit - Digital inputs					
Number		8			
Inputs can be used as analog inputs		2 (I7, I8)			-
Indication of operational states		LCD-Display (if existing)			
Electrical isolation	from voltage supply	no			
	between digital inputs	no			
	from the outputs	yes			
Rated operational voltage U_e		12 V DC	24 V DC	24 V AC	
	U_e on „0“ signal	4 V DC (I1-I8)	< 5 V DC (I1-I8)	0-6 V AC (sinusoidal)	0-40 V AC (sinusoidal)
	U_e on „1“ signal	8 V DC (I1-I8)	> 15 V DC (I1-I6), > 8 V DC (I7, I8)	> 9.5 V DC, 14-26.4 V AC (sinusoidal) (I1-I6), > 7 V AC (sinusoidal) (I7,I8)	79-264 V AC (sinusoidal)
Rated frequency		-		50-60 Hz	
Input current on „1“ signal		3.3 mA (at 12 V DC, I1-I6), 1.1 mA (at 12 V DC, I7, I8)	3.3 mA (at 24 V DC, I6-I7), 2.2 mA (at 24 V DC, I7, I8)	4 mA (at 24 V AC, 50 Hz, I1-I6), 2 mA (at 24 V AC, 50 Hz, I7,I8), 2 mA (at 24 V DC, I7, I8)	6x0.25 mA (at 115 V AC, 60 Hz, I1-I6), 6x0.5 mA (at 230 V AC, 50 Hz, I1-I6) 2x4 mA (at 115 V AC, 60 Hz, I7, I8), 2x6 mA (at 230 V AC, 50 Hz, I7, I8)
Time delay from „0“ to „1“	debounce ON	20 ms		80 ms (at 50 Hz), 66 2/3 ms (at 60 Hz)	
	debounce OFF	typ. 0.3 ms (I1-I6), typ. 0.35 ms (I7, I8)	typ. 0.25 ms (I1-I8)	20 ms (at 50 Hz), 16 2/3 ms (at 60 Hz)	
Time delay from „1“ to „0“	debounce ON	20 ms		80 ms (at 50 Hz), 66 2/3 ms (at 60 Hz)	80 ms (at 50 Hz, I1-I6), 66 2/3 ms (at 60 Hz, I1-I6) 160 ms (at 50 Hz, I7, I8), 150 ms (at 60 Hz, I7, I8)
	debounce OFF	typ. 0.3 ms (I1-I6), typ. 0.15 ms (I7, I8)	-	20 ms (at 50 Hz), 16 2/3 ms (at 60 Hz)	20 ms (at 50 Hz, I1-I6), 16 2/3 ms (at 60 Hz, I1-I6) 100 ms (at 50 Hz, I7, I8), 100 ms (at 60 Hz, I7, I8)
Cable length (unshielded)		100 m		-	-
Maximum cable length per input		-		40 m	40 m (I1-I6), 100 m (I7, I8)
Frequency counter	Number	2 (I3, I4)		-	-
	counting frequency	< 1 kHz		-	-
	pulse shape	square-wave		-	-
	pulse / pause ratio	1:1		-	-
Rapid counter inputs	Number	2 (I1, I2)		-	-
	counting frequency	< 1 kHz		-	-
	pulse shape	square-wave		-	-
	pulse / pause ratio	1:1		-	-
Cable length (shielded)		< 20 m		-	-
Input circuit - Analog inputs					
Number		2 (I7, I8)			-
Electrical isolation	from voltage supply	no			-
	from the digital inputs	no			-
	from the outputs	yes			-
	from PC interface, memory module, CL-NET, CL-LINK	no			-
Input type		DC voltage			-
Signal range		0-10 V DC			-
Resolution	analog	0.01 V			-
	digital	0.01 V; 10 Bit (value 1-1023)			-
Input impedance		11.2 k Ω			-
Accuracy of the actual value	two CL devices	$\pm 3\%$			-
	within one device	$\pm 2\%$, $\pm 0.12\text{ V}$			-
Conversion time	Input delay ON	20 ms			-
analog/digital	Input delay OFF	each cycle			-
Input current		< 1 mA			-
Cable length (shielded)		< 30 m			-

Logic relays

Technical data

Data at $T_a = 25\text{ °C}$ and rated values, if nothing else indicated.

Type		CL-LMR.C...18DC1	CL-LMR.C...18DC2 CL-LMT.C...20DC2	CL-LMR.C...18AC1	CL-LMR.C...18AC2
Input circuit - Digital inputs		12 V DC	24 V DC	24 V AC	115 / 230 V AC
Number		12			
Inputs can be used as analog inputs		4 (I7, I8, I11, I12)			-
Indication of operational states		LCD-Display (if existing)			
Electrical isolation	from voltage supply	no			
	between digital inputs	no			
	from the outputs	yes			
	from PC interface, memory module, CL-NET, CL-LINK	no			yes
Rated operational voltage U_e		12 V DC	24 V DC	24 V AC	
	U_e on „0“ signal	4 V DC (I1-I12)	< 5 V DC (I1-I12, R1-R12)	0-6 V AC (sinusoidal)	0-40 V AC (sinusoidal)
	U_e on „1“ signal	8 V DC (I1-I12)	> 15 V DC (I1-I6, I9, I10) > 8 V DC (I7, I8, I11, I12)	> 9.5 V DC, 14-26.4 V AC (sinusoidal) (I1-I6, I9, I10) > 7 V AC (sinusoidal) (I7, I8, I11, I12)	79-264 V AC (sinusoidal)
Rated frequency		-		50-60 Hz	
Input current on „1“ signal		3.3 mA (at 12 V DC, I1-I6, I9-I12), 1.1 mA (at 12 V DC, I7, I8)	3.3 mA (at 24 V DC, I1-I6, I9, I10), 2.2 mA (at 24 V DC, I7, I8, I11, I12)	4 mA (at 24 V AC, 50 Hz, I1-I6, I9, I10), 2 mA (at 24 V AC, 50 Hz, I7, I8, I11, I12), 2 mA (at 24 V DC, I7, I8, I11, I12)	6x0.25 mA (at 115 V AC, 60 Hz, I1-I6), 6x0.5 mA (at 230 V AC, 50 Hz, I1-I6) 2x4 mA (at 115 V AC, 60 Hz, I7, I8), 2x6 mA (at 230 V AC, 50 Hz, I7, I8), 4x0.25 mA (at 115 V AC, 60 Hz, I9-I12), 4x0.5 mA (at 230 V AC, 50 Hz, I9-I12)
Time delay from „0“ to „1“	debounce ON	20 ms		80 ms (at 50 Hz), 66 2/3 ms (at 60 Hz)	
	debounce OFF	typ. 0.3 ms (I1-I6, I9, I10), typ. 0.35 ms (I7, I8, I11, I12)	typ. 0.25 ms	20 ms (at 50 Hz), 16 2/3 ms (at 60 Hz)	
Time delay from „1“ to „0“	debounce ON	20 ms		80 ms (at 50 Hz), 66 2/3 ms (at 60 Hz)	
	debounce OFF	typ. 0.4 ms (I1-I6, I9, I10), typ. 0.35 ms (I7, I8, I11, I12)		20 ms (at 50 Hz), 16 2/3 ms (at 60 Hz)	
Cable length (unshielded)		100 m			
Maximum cable length per input				max. 40 m, typ. 40 m (I9, I10)	typ. 40 m (I1-I6, I9-I12), typ. 100 m (I7, I8)
Frequency counter	number	2 (I3, I4)		-	-
	counting frequency	< 1 kHz		-	-
	pulse shape	square-wave		-	-
	pulse / pause ratio	1:1		-	-
Rapid counter inputs	number	2 (I1, I2)		-	-
	counting frequency	< 1 kHz		-	-
	pulse shape	square-wave		-	-
	pulse / pause ratio	1:1		-	-
Cable length (shielded)		< 20 m		-	-
Input circuit - Analog inputs					
Number		4 (I7, I8, I11, I12)			
Electrical isolation	from voltage supply	no			
	from the digital inputs	no			
	from the outputs	yes			
	from PC interface, memory module, CL-NET, CL-LINK	no			
Input type		DC voltage			
Signal range		0-10 V DC			
Resolution	analog	0.01 V			
	digital	0.01 V; 10 Bit (value 1-1023)			
Input impedance		11.2 k Ω			
Accuracy of the actual value	two CL devices	$\pm 3\%$			
	within one device	$\pm 2\%$, $\pm 0.12\text{ V}$			
Conversion time	Input delay ON	20 ms			
analog/digital	Input delay OFF	each cycle			
Input current		< 1 mA			
Cable length (shielded)		< 30 m			

Logic relays

Technical data

Data at $T_a = 25\text{ °C}$ and rated values, if nothing else indicated.

Type		CL-LER.18DC2, CL-LET.20DC2	CL-LER.18AC2
Input circuit - Digital inputs		24 V DC	115 / 230 V AC
Number		12	
Inputs can be used as analog inputs		-	
Indication of operational states		-	
Electrical isolation	from voltage supply	no	
	between digital inputs	no	
	from the outputs	yes	
	from PC interface, memory module, CL-NET, CL-LINK	no	
Rated operational voltage U_e		24 V DC	
	U_e on „0“ signal	< 5 V DC (I1-I12, R1-R12)	0-40 V AC (sinusoidal)
	U_e on „1“ signal	-	79-264 V AC (sinusoidal)
Rated frequency		-	50-60 Hz
Input current on „1“ signal		3.3 mA (at 24 V DC, R1-R12)	12x0.25 mA (at 115 V AC, 60 Hz, R1-R12), 12x0.5 mA (at 230 V AC, 50 Hz, R1-R12)
Time delay from „0“ to „1“	debounce ON	20 ms	80 ms (at 50 Hz, I1-I12, R1-R12), 66 2/3 ms (at 60 Hz, I1-I12, R1-R12)
	debounce OFF	typ. 0.25 ms (R1-R12)	20 ms (at 50 Hz, I1-I12, R1-R12), 16 2/3 ms (at 60 Hz, I1-I12, R1-R12)
Time delay from „1“ to „0“	debounce ON	20 ms	80 ms (at 50 Hz, I1-I12, R1-R12), 66 2/3 ms (at 60 Hz, I1-I12, R1-R12)
	debounce OFF	-	20 ms (at 50 Hz, I1-I12, R1-R12), 16 2/3 ms (at 60 Hz, I1-I12, R1-R12)
Cable length (unshielded)		100 m	-
Maximum cable length per input		-	typ. 40 m (I1-I6, I9-I12, R1-R12), typ. 100 m (I7, I8)

Logic relays

Technical data

Data at $T_a = 25\text{ °C}$ and rated values, if nothing else indicated.

Type	CL-LSR...	CL-LMR... CL-LER...	CL-LER.20
Output circuit - Relay outputs			
Number	4	6	2
Outputs in groups of	1		2
Parallel switching of outputs to increase capacity	not permissible		
Fusing of the output relay	circuit-breaker B16 or fuse 8 A (slow-acting)		
Electrical isolation	from voltage supply	yes	
	from the inputs	yes	
	from PC interface, memory module, CL-NET, CL-LINK	no	
	protective separation	300 V AC	
	basic isolation	600 V AC	
Mechanical lifetime	10x10 ⁶ switching cycles		
Rung	conventional thermal current (10 A UL)	8 A	
	recommended for load 12 V AC/DC	> 500 mA	
	short-circuit proof $\cos \varphi = 1$; characteristic B16 at 600 A	16 A	
	short-circuit proof $\cos \varphi = 0,5$ up to 0,7; characteristic B16 at 900 A	16 A	
	Rated impulse withstand voltage U_{imp} contact-coil	6 kV	
	Rated operational voltage U_o	250 V AC	
Rated insulation voltage U_i	250 V AC		
Protective separation (EN 50178)	between coil and contact	300 V AC	
	between two contacts	300V AC	
Making capacity	AC-15, 250 V AC, 3 A (600 ops./h)	300.000 switching cycles	
	DC13, L/R \leq 150 ms, 24 V DC, 1 A (500 ops./h)	200.000 switching cycles	
Breaking capacity	AC-15, 250 V AC, 3 A (600 ops./h)	300.000 switching cycles	
	DC13, L/R \leq 150 ms, 24 V DC, 1 A (500 ops./h)	200.000 switching cycles	
Incandescent lamp load	1000 W at 230/240 V AC	25.000 switching cycles	
	500 W at 115/120 V AC	25.000 switching cycles	
Fluorescent lamp load	10 x 58 W at 230/240 V AC with electrical control gear	25.000 switching cycles	
	10 x 58 W at 230/240 V AC uncompensated	25.000 switching cycles	
	1 x 58 W at 230/240 V AC conventional compensated	25.000 switching cycles	
Switching frequency	mechanical operations	10x10 ⁶	
	switching frequency	10 Hz	
	resistive load / lamp load	2 Hz	
	inductive load	0.5 Hz	
UL/CSA			
Continuous current at 240 V	10 A AC		
Continuous current at 24 V	8 A DC		
AC	Utilization category (Control Circuit Rating Codes)	B 300 Light Pilot Duty	
	max. rated operational voltage	300 V AC	
	max. continuous thermal current $\cos \varphi =$ 1 at B 300	5 A	
	max. making / breaking apparent power (Make/Break) $\cos \varphi \neq 1$ at B 300	3600/360 VA	
DC	Utilization category (Control Circuit Rating Codes)	R 300 Light Pilot Duty	
	max. rated operational voltage	300 V DC	
	max. continuous thermal current at R 300	1 A	
	max. making / breaking apparent power (Make/Break) at R 300	28/28 VA	

Logic relays

Technical data

Data at $T_a = 25\text{ °C}$ and rated values, if nothing else indicated.

Type	CL-LST...	CL-LMT...	CL-LET...
Output circuit - Transistor outputs			
Number	4	8	
Rated operational voltage U_e	24 V DC		
Operational voltage range	20.4-28.8 V DC		
Residual ripple	≤ 5 %		
Supply current	on „0“ signal on „1“ signal	typ. 9 mA / max. 16 mA typ. 12 mA / max. 22 mA	typ. 18 mA / max. 32 mA typ. 24 mA / max. 44 mA
Reverse voltage protection	yes (Attention: If supply voltage is reversed, applying voltage at the outputs, causes a short circuit.)		
Electrical isolation	from voltage supply from the inputs	yes yes	
	from PC interface, memory module, CL-NET, CL-LINK	-	
Rated operational current I_e on „1“ signal DC	max. 0.5 A		
Lamp load without R_v	5 W		
Residual current on „0“ signal per channel	< 0.1 mA		
Max. output voltage	on „0“ signal at external load < 10 MΩ	2.5 V	
	on „1“ signal at $I_e = 0.5\text{ A}$	$U = U_e - 1\text{ V}$	
Short-circuit protection	yes, thermal (analysis results from diagnosis input I16, I15; R15, R16)		
Short-circuit tripping current for $R_a \leq 10\text{ m}\Omega$	$0.7\text{ A} \leq I_e \leq 2\text{ A}$ per output		
Total short-circuit current	8 A	16 A	
Peak short-circuit current	16 A	32 A	
Thermal tripping	yes		
Max. switching frequency with constant resistive load $R_L < 100\text{ k}\Omega$ (depending on active channels and their load)	40.000 switching cycles/h		
Parallel connection of outputs	with resistive load, inductive load with external suppressor, combination within one group	group 1: Q1-Q4 group 2: Q5-Q8	group 1: S1-S4, group 2: S5-S8
	number of outputs	max. 4	
	max. total current	2 A (Attention! Outputs must be actuated simultaneously and for the same length of time.)	
Indication of operational states of the outputs	LCD-Display (if existing)		
Inductive load ¹⁾ without external suppressor			
$T_{0.95} = 1\text{ ms}$, $R = 48\ \Omega$, $L = 16\text{ mH}$	utilization factor	0.25 g	
	duty time	100 %	
	max. switching frequency $f = 0.5\text{ Hz}$ (max. duty time = 50 %)	1500 switching cycles	
DC13, $T_{0.95} = 72\text{ ms}$, $R = 48\ \Omega$, $L = 1.15\text{ H}$	utilization factor	0.25 g	
	duty time	100 %	
	max. switching frequency $f = 0.5\text{ Hz}$ (max. duty time = 50 %)	1500 switching cycles	
$T_{0.95} = 15\text{ ms}$, $R = 48\ \Omega$, $L = 0.24\text{ H}$	utilization factor	0.25 g	
	duty time	100 %	
	max. switching frequency $f = 0.5\text{ Hz}$ (max. duty time = 50 %)	1500 switching cycles	
Inductive load ¹⁾ with external suppressor			
	demand factor	1 g	
	duty time	100 %	
	max. switching frequency	depends on suppressor	
	max. duty time		

1) For inductive loading, without external suppression of the transistor outputs, the following applies:
 $T_{0.95}$ = time in ms, until 95 % of the steady-state current is achieved. $T_{0.95} \cdot 3 \times T_{0.65} = 3 \times L/R$.

Data transfer rate in the CL-NET network: bus lengths of 40 m and over only attainable with cables with additional cross-section and connection adapter.

Logic relays

Technical data

Data at $T_a = 25\text{ °C}$ and rated values, if nothing else indicated.

Type	CL-LET..., CL-LMT... CL-LST...	CL-LER.18... CL-LMR... CL-LSR..	CL-LER.20 CL-LEC.C1000
General data			
Dimensions	see 'Dimensional drawings'		
Mounting	DIN rail (IEC/EN 60715), 35 mm or screw mounting with fixing brackets		
Mounting position	horizontal / vertical		
Electrical connection			
Connecting capacity	rigid fine-strand with wire end ferrule	0.2-4 mm ² (22-12 AWG) 0.2-2.5 mm ² (22-12 AWG)	
Max. tightening torque	0.6 Nm		
Environmental data			
Ambient temperature range	operation storage	-25...+55 °C, cold acc. to IEC 60068-2-1, heat acc. to IEC 60068-2-2 -40...+70 °C	
LCD-Display (clearly legible)	0...+55 °C		
Condensation	avoid condensation with suitable methods		
Humidity, no condensation (IEC/EN 60068-2-30)	5-95 %		
Air pressure (operation)	795-1080 hPa		
Degree of protection (IEC/EN 60529)	IP20		
Vibration (IEC/EN 60068-2-6)	10-57 Hz (constant amplitude 0.15 mm), 57-150 Hz (constant acceleration 2 g)		
Shock resistance (half-sine 15 g / 11 ms) (IEC/EN 60068-2-27)	18 Shocks		
Drop (IEC/EN 60068-2-31) height of fall	50 mm		
Free fall, packaged (IEC/EN 60068-2-32)	1 m		
Isolation data			
Overvoltage category	II		
Pollution degree (DIN EN 60947)	2		
Rating of air and creepage distances	EN 50178, UL 508, CSA C22.2, No. 142		
Insulation resistance	EN 50178		
Directives			
Low Voltage Directive	-	2014/35/EU	
EMC Directive	2014/30/EU		
RoHS Directive	2011/65/EU		
Electromagnetic compatibility			
Interference immunity to		IEC/EN 61000-6-2	
electrostatic discharge (ESD)	IEC/EN 61000-4-2	Level 3 (air discharge 8 kV, contact discharge 6 kV)	
radiated, radio-frequency, electromagnetic field	IEC/EN 61000-4-3	10 V/m	
electrical fast transient / burst	IEC/EN 61000-4-4	Level 3 (supply cable 2 kV, signal lines 2 kV)	
surge	IEC/EN 61000-4-5	supply cable symmetrical (AC) 2 kV, Level 2 (supply cable symmetrical (DC) 0.5 kV)	
conducted disturbances, induced by radio-frequency fields	IEC/EN 61000-4-6	10 V	
Interference emission		IEC/EN 61000-6-3	
Real time clock			
Back-up time	see diagram		-
Accuracy	typ. ±5 (±0.5 h/year)		-
Repeat accuracy of the time relay			
Accuracy (from value)	±1		-
Resolution	range „S“	10 ms	-
	range „M:S“	1 s	-
	range „H:M“	1 min	-
Retention behaviour			
Write cycles of retention memory (minimum)	1.000.000 (10 ⁶)		-

Technical diagram

Back-up time of the real time clock

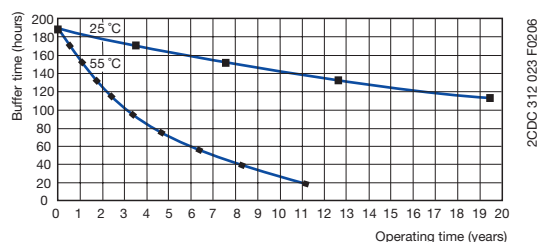

Logic relays

Technical data

Data at $T_a = 25\text{ °C}$ and rated values, if nothing else indicated.

Type		CL-LDD...
Input circuit - Supply circuit		
Power failure buffering (IEC/EN 61131-2)		10 ms
General data		
Dimensions		see 'Dimensional drawings'
Mounting		2 x 22.5 mm, with 2 retainers screwed
Mounting position		horizontal / vertical
Environmental data		
Ambient temperature range	operation	-25...+55 °C (cold acc. to IEC 60068-2-1, heat acc. to IEC 60068-2-2)
	storage	-40...+70 °C
LCD-Display (clearly legible)		-5...+50 °C, -10...0 °C (with backlit / continuous operation)
Condensation		avoid condensation with suitable methods
Humidity, no condensation (IEC/EN 60068-2-30)		5-95 %
Air pressure (operation)		795-1080 hPa
Degree of protection (IEC/EN 60529)		IP65
Vibration (IEC/EN 60068-2-6)		10-57 Hz (constant amplitude 0.15 mm), 57-150 Hz (constant acceleration 2 g)
Shock resistance (half-sine 15 g / 11 ms) (IEC/EN 60068-2-27)		18 Shocks
Drop (IEC/EN 60068-2-31) height of fall		50 mm
Free fall, packaged (IEC/EN 60068-2-32)		1 m
Isolation data		
Pollution degree (DIN EN 60947)		3
Rating of air and creepage distances		EN 50178, UL 508, CSA 22.2, No 142
Insulation resistance		EN 50178
Directives		
EMC Directive		2014/30/EU
RoHS Directive		2011/65/EU
Electromagnetic compatibility		
Interference immunity		IEC/EN 61000-6-2
electrostatic discharge (ESD)	IEC/EN 61000-4-2	Level 3 (air discharge 8 kV, contact discharge 6 kV)
radiated, radio-frequency, electromagnetic field	IEC/EN 61000-4-3	10 V/m
electrical fast transient / burst	IEC/EN 61000-4-4	Level 3 (supply cable 2 kV, signal lines 2 kV)
surge	IEC/EN 61000-4-5	Level 3 (supply cable symmetrical 2 kV, CL-LDC.L...AC2) Level 2 (0.5 kV supply cable symmetrical, CL-LDC.L...AC2)
conducted disturbances, induced by radio-frequency	IEC/EN 61000-4-6	10 V
Interference emission		IEC/EN 61000-6-3

Logic relays

Technical data

Data at $T_a = 25\text{ °C}$ and rated values, if nothing else indicated.

Type	CL-LDC.SDC2	CL-LDC.SAC2	CL-LDC.LDC2	CL-LCD.LAC2	CL-LDC.LNDC2	CL-LDC.LNAC2
Input circuit - Supply circuit						
Rated operational voltage U_g	24 V DC	100-240 V AC	24 V DC	100-240 V AC	24 V DC	100-240 V AC
Rated operational voltage tolerance	-15...+20 %	-15...+10 %	-15...+20 %	-15...+10 %	-15...+20 %	-15...+10 %
Operational voltage range	20.4-28.8 V DC	85-264 V AC	20.4-28.8 V DC	85-264 V AC	20.4-28.8 V DC	85-264 V AC
Frequency	0 Hz	50/60 Hz	0 Hz	50/60 Hz	0 Hz	50/60 Hz
Frequency tolerance	-	± 5 %	-	± 5 %	-	± 5 %
Residual ripple	≤ 5 %	-	≤ 5 %	-	≤ 5 %	-
Input current	at 24 V DC typ. 185 mA	-	typ. 200 mA	-	typ. 200 mA	-
	at 115/120 V AC (60 Hz)	typ. 90 mA	-	typ. 90 mA	-	typ. 90 mA
	at 230/240 V AC (50 Hz)	typ. 60 mA	-	typ. 60 mA	-	typ. 60 mA
Power failure buffering (IEC/EN 61131-2)	10 ms	-	-	-	-	-
Power dissipation	at 24 V DC 1.5 W	-	3.4 W	-	3.4 W	-
	at 115/120 V AC	typ. 11 VA	-	typ. 11 VA	-	typ. 11 VA
	at 230/240 V AC	typ. 15 VA	-	typ. 15 VA	-	typ. 15 VA
Network - point-to-point connection						
Number of stations	CL-LS..., CL-LM..., CL-LDD	1	-	-	-	-
Data transfer rate		9.6 kBaud	-	-	-	-
		19.2 kBaud	-	-	-	-
Distance		max. 5 m	-	-	-	-
Electrical isolation	to voltage supply	yes	-	-	-	-
	to connected device	yes	-	-	-	-
Termination system		spring-type terminal	-	-	-	-
Network - CL-NET						
Number of stations		max. 1	-	-	max. 8	-
Data transfer rate	6 m	-	-	-	1000 kBit/s	-
	25 m	-	-	-	500 kBit/s	-
	40 m	-	-	-	250 kBit/s	-
	125 m	-	-	-	125 kBit/s	-
	300 m	-	-	-	50 kBit/s	-
	700 m	-	-	-	20 kBit/s	-
	1000 m	-	-	-	10 kBit/s	-
Electrical isolation	to voltage supply	-	-	-	yes	-
	to inputs	-	-	-	yes	-
	to outputs	-	-	-	yes	-
	to PC interface, memory module, CL-NET, CL-LINK	-	-	-	yes	-
Bus terminator (first and last station)		-	-	-	yes	-
Termination system		-	-	-	RJ45, 8 pole	-
General data						
Dimensions		see 'Dimensional drawings'				
Mounting		plugged onto CL-LDD	plugged onto CL-LDD or on DIN rail (IEC/EN 60715)			
Mounting position						
Electrical connection - Supply circuit						
Connecting capacity	fine-strand with wire end ferrule	0.2 mm ² / 2.5 mm ² (24-12 AWG)				
	rigid	0.2 mm ² / 4 mm ² (24-12 AWG)				
Electrical connection - Data cable						
Connecting capacity	fine-strand with wire end ferrule	0.08 mm ² / 1.5 mm ² (28-12 AWG)		-		
	rigid	0.08 mm ² / 2.5 mm ² (28-12 AWG)		-		
				0.2 mm ² / 2.5 mm ² (24-12 AWG)		
				0.2 mm ² / 4 mm ² (24-12 AWG)		
Environmental data						
Ambient temperature range	operation	-25...+55 °C (cold acc. to IEC 60068-2-1, heat acc. to IEC 60068-2-2)				
	storage	-40...+70 °C				
Condensation		avoid condensation with suitable methods				
Humidity, no condensation (IEC/EN 60068-2-30)		5-95 %				
Air pressure (operation)		795-1080 hPa				
Degree of protection (IEC/EN 60529)		IP20				
Vibration (IEC/EN 60068-2-6)		10-57 Hz (constant amplitude 0.15 mm), 57-150 Hz (constant acceleration 2 g)				

Logic relays

Technical data

Data at $T_a = 25\text{ °C}$ and rated values, if nothing else indicated.

Type	CL-LDC. SDC2	CL-LDC. SAC2	CL-LDC. LDC2	CL-LCD. LAC2	CL-LDC. LNDC2	CL-LDC. LNAC2
Shock (half-sine 15 g / 11 ms) (IEC/EN 60068-2-27)	18 Shocks					
Drop (IEC/EN 60068-2-31) height of fall	50 mm					
Free fall, packaged (IEC/EN 60068-2-32)	1 m					
Isolation data						
Degree of protection (DIN EN 60947)	2					
Rating of air and creepage distances	EN 50178, UL 508, CSA 22.2, No 142					
Isolation resistance	EN 50178					
Directives						
Low Voltage Directive	-	2014/35/EU	-	2014/35/EU	-	2014/35/EU
EMC Directive	2014/30/EU					
RoHS Directive	2011/65/EU					
Electromagnetical compatibility						
Interference immunity to electrostatic discharge (ESD)	IEC/EN 61000-4-2	Level 3 (air discharge 8 kV, contact discharge 6 kV)				
radiated, radio-frequency, electromagnetic field	IEC/EN 61000-4-3	10 V/m				
electrical fast transient / burst surge	IEC/EN 61000-4-4	Level 3 (supply cable 2 kV, signal lines 2 kV)				
	IEC/EN 61000-4-5	Level 3 (supply cable symmetrical 2 kV, CL-LDC.L...AC2)				
		Level 2 (1 kV supply cable symmetrical)		Level 2 (0.5 kV supply cable symmetrical, CL-LDC.L...AC2)		
conducted disturbances, induced by radio-frequency	IEC/EN 61000-4-6	10 V				
Interference emission	IEC/EN 61000-6-3					
Real time clock						
Back-up time	-		see diagram			
Accuracy	-		typ. ± 5 s/day ($\pm 0,5$ h/year)			
Repeat accuracy of the time relay						
Accuracy (from value)	-		$\pm 0.02\%$			
Resolution	range „S“	-		5 ms		
	range „M:S“	-		1 s		
	range „H:M“	-		1 min		
Retention behaviour						
Write cycles of retention memory (minimum)	-		10^{10} (read/ write cycles)			

Technical diagram

Back-up time of the real time clock

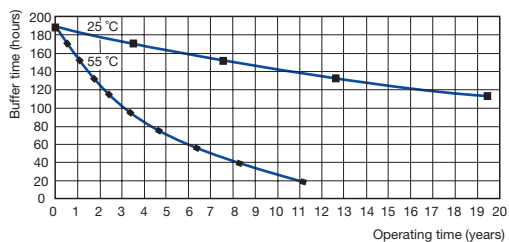

2CDC 312 023 F0206

Logic relays

Technical data

Data at $T_a = 25\text{ °C}$ and rated values, if nothing else indicated.

Type		CL-LD...16DC2	CL-LD...17DC2	CL-LDR.16AC2
Input circuit - Digital inputs		24 V DC		115/230 V
Number		12		
Inputs can be used as analog inputs		4 (I7, I8, I11, I12)		-
Indication of operational states		-		LCD-Display (if existing)
Electrical isolation	from supply voltage	no		
	from digital inputs	no		
	from the outputs	yes		
	from PC interface, memory module, CL-NET, CL-LINK	yes		
Rated operational voltage U_e		24 V DC		-
	U_e on „0“ signal	< 5 V DC (I1-I6, I9, I10), < 8 V DC (I7, I8, I11, I12)		0-40 V AC (sinusoidal)
	U_e on „1“ signal	> 15 V DC (I1-I6, I9, I10), > 8 V DC (I7, I8, I11, I12)		79-264 V AC (sinusoidal)
Rated frequency		0 Hz		50-60 Hz
Input current on „1“ signal		3,3 mA (at 24 V DC, I1-I6, I9, I10), 2,2 mA (at 24 V DC, I7, I8, I11, I12)		12x0,2 mA (at 115 V AC, 60 Hz, I1-I12), 12x0,5 mA (at 230 V AC, 50 Hz, I1-I12)
Time delay from „0“ to „1“	debounce ON	20 ms		10 ms (at 50 Hz), 100 ms (at 60 Hz)
	debounce OFF	typ. 0.1 ms (I1-I4), typ. 0.25 ms (I5-I12)		10 ms (at 50 Hz), 100 ms (at 60 Hz)
Time delay from „1“ to „0“	debounce ON	20 ms		10 ms (at 50 Hz), 100 ms (at 60 Hz)
	debounce OFF	typ. 0.1 ms (I1-I4), typ. 0.4 ms (I5, I6, I9, I10), typ. 0.2 ms (I7, I8, I11, I12)		10 ms (at 50 Hz), 100 ms (at 60 Hz)
Cable length (unshielded)		100 m		-
Maximum cable length per input		-		typ. 60 m
Frequency counter	number	4 (I1, I2, I3, I4)		-
	counting frequency	< 3 kHz		-
	pulse shape	square-wave		-
	pulse / pause ratio	1:1		-
Incremental counter	number	2 (I1 + I2, I3 + I4)		-
	counting frequency	< 3 kHz		-
	pulse shape	square-wave		-
	signal offset	90°		-
Rapid counter inputs	number	4 (I1, I2, I3, I4)		-
	counting frequency	< 3 kHz		-
	pulse shape	square-wave		-
	pulse / pause ratio	1:1		-
Cable length (shielded)		< 20 m		-
Input circuit - Analog inputs				
Number		4 (I7, I8, I11, I12)		-
Electrical isolation	to voltage supply	no		-
	to digital inputs	no		-
	to outputs	yes		-
	to PC interface, memory modul, CL-NET, CL-LINK	yes		-
Input type		DC voltage		-
Signal range		0-10 V DC		-
Resolution	analog	0.01 V		-
	digital	0.01 V; 10 Bit (value 0-1023)		-
Input impedance		11,2 kΩ		-
Accuracy of the actual value	two CL-LD... devices	± 3 %		-
	within one device	± 2 %		-
Conversion time analog/digital		each cycle		-
Input current		< 1 mA		-
Cable length (shielded)		< 30 m		-

Logic relays

Technical data

Data at $T_a = 25\text{ °C}$ and rated values, if nothing else indicated.

Type		CL-LD...16DC2	CL-LD...17DC2	CL-LDR.16AC2
Output circuit - Analog outputs				
Number		-	1	-
Electrical separation	from voltage supply	-	no	-
	from the digital inputs	-	no	-
	from the digital outputs	-	yes	-
	from PC interface, memory module, CL-NET, CL-LINK	-	yes	-
Output type		-	DC voltage	-
Signal range		-	0-10 V DC	-
Max. output current		-	0.01 A	-
Burden resistance		-	1 k Ω	-
Overload and short-circuit protection		-	yes	-
Resolution	analog	-	0.01 V DC	-
	digital	-	10 Bit, (value: 0-1023)	-
Setting time		-	100 ms	-
Accuracy	-25...+55 °C	-	2 %	-
	25 °C	-	1 %	-
Conversion time		-	each CPU cycle	-
General data				
Dimensions		see 'Dimensional drawings'		
Mounting		snap-on power supply unit		
Mounting position		horizontal / vertical		
Electrical connection - Supply circuit				
Connecting capacity	fine-strand with wire end ferrule	0.2 mm ² / 2.5 mm ² (24-12 AWG)		
	rigid	0.2 mm ² / 4 mm ² (24-12 AWG)		
Electrical connection - Data cable				
Connecting capacity	fine-strand with wire end ferrule	0.08 mm ² / 1.5 mm ² (28-12 AWG)		
	rigid	0.08 mm ² / 2.5 mm ² (28-12 AWG)		
Environmental data				
Ambient temperature range	operation	-25...+55 °C (cold acc. to IEC 60068-2-1, heat acc. to IEC 60068-2-2)		
	storage	-40...+70 °C		
Condensation		avoid condensation with suitable methods		
Humidity, no condensation (IEC/EN 60068-2-30)		5-95 %		
Atmospheric pressure (operation)		795-1080 hPa		
Degree of protection (IEC/EN 60529)		IP20		
Vibration (IEC/EN 60068-2-6)		10-57 Hz (constant amplitude 0.15 mm), 57-150 Hz (constant acceleration 2 g)		
Shock (half-sine 15 g / 11 ms) (IEC/EN 60068-2-27)		18 Shocks		
Drop (IEC/EN 60068-2-31) height of fall		50 mm		
Free fall, packaged (IEC/EN 60068-2-32)		1 m		
Isolation data				
Pollution degree		2		
Rating of air and creepage distances		EN 50178, UL 508, CSA C22.2, No. 142		
Isolation resistance		EN 50178		
Directives				
Low Voltage Directive		CL-LDR. 16DC2	CL-LDT. 16DC2	CL-LDR. 16AC2
EMC Directive		2014/35/EU -	2014/35/EU -	2014/35/EU
RoHS Directive		2014/30/EU		
		2011/65/EU		
Electromagnetic compatibility				
Interference immunity to electrostatic discharge (ESD)	IEC/EN 61000-4-2	IEC/EN 61000-6-2		
radiated, radio-frequency, electromagnetic field	IEC/EN 61000-4-3	Level 3 (air discharge 8 kV, contact discharge 6 kV)		
electrical fast transient / burst surge	IEC/EN 61000-4-4	10 V/m		
	IEC/EN 61000-4-5	Level 3 (supply cable 2 kV, signal cable 2 kV)		
		2 kV (supply cable symmetrical), Level 2 (0.5 kV supply cable symmetrical)		
conducted disturbances, induced by radio-frequency	IEC/EN 61000-4-6	10 V		
Interference emission		IEC/EN 61000-6-3		

Logic relays

Technical data

Data at $T_a = 25\text{ °C}$ and rated values, if nothing else indicated.

Type		CL-LDR...
Output circuit - Relay outputs		
Number		4
Outputs in groups of		-
Parallel switching of outputs to increase capacity		not permissible
Fusing of the output relay		circuit-breaker B16 or fuse 8 A (slow-acting)
Electrical isolation	from voltage supply	yes
	from the inputs	yes
	from PC interface, memory module, CL-NET, CL-LINK	yes
	protective separation	300 V AC
	Basic isolation	600 V AC
Mechanical lifetime		10×10^6 switching cycles
Rung	conventional thermal current (10 A UL)	8 A
	recommended load 12 V AC/DC	> 500 mA
	short-circuit proof $\cos \varphi = 1$; characteristic B16 at 600 A	16 A
	short-circuit proof $\cos \varphi = 0.5$ up to 0.7; characteristic B16 at 900 A	16 A
	Rated impulse withstand voltage U_{imp} contact-coil	6 kV
	Rated operational voltage U_e	250 V AC
Rated insulation voltage U_i		250 V AC
Protective separation (EN 50178)	between coil and contact	300 V AC
	between two contacts	300 V AC
Making capacity	AC-15, 250 V AC, 3 A (600 ops./h)	300.000 switching cycles
	DC13, L/R ≤ 150 ms, 24 V DC, 1 A (500 ops./h)	200.000 switching cycles
Breaking capacity	AC-15, 250 V AC, 3 A (600 ops./h)	300.000 switching cycles
	DC13, L/R ≤ 150 ms, 24 V DC, 1 A (500 ops./h)	200.000 switching cycles
Incandescent lamp load	1000 W at 230/240 V AC	25.000 switching cycles
	500 W at 115/120 V AC	25.000 switching cycles
Fluorescent lamp load	10 x 58 W at 230/240 V AC with electrical control gear	25.000 switching cycles
	10 x 58 W at 230/240 V AC uncompensated	25.000 switching cycles
	1 x 58 W at 230/240 V AC conventional compensated	25.000 switching cycles
		25.000 switching cycles
Switching frequency	mechanical operations	10×10^6
	switching frequency	10 Hz
	resistive load / lamp load	2 Hz
	inductive load	0.5 Hz
UL/CSA		
Continuous current at 240 V		10 A AC
Continuous current at 24 V		8 A DC
AC	Utilization category (Control Circuit Rating Codes)	B 300 Light Pilot Duty
	max. rated operational voltage	300 V AC
	max. continuous thermal current $\cos \varphi = 1$ at B 300	5 A
	max. making / breaking apparent power (Make/Break) $\cos \varphi \neq 1$ at B 300	3600/360 VA
DC	Utilization category (Control Circuit Rating Codes)	R 300 Light Pilot Duty
	max. rated operational voltage	300 V DC
	max. continuous thermal current at R 300	1 A
	max. making / breaking apparent power (Make/Break) at R 300	28/28 VA

Logic relays

Technical data

Data at $T_a = 25\text{ °C}$ and rated values, if nothing else indicated.

Type	CL-LDT...
Output circuit - Transistor outputs	
Number	4
Rated operational voltage U_e	24 V DC
Operational voltage range	20.4-28.8 V DC
Residual ripple	-
Supply current	on „0“ signal typ. 18 mA / max. 32 mA on „1“ signal typ. 24 mA / max. 44 mA
Reverse voltage protection	yes (Attention: If supply voltage is reversed, applying voltage at the outputs, causes a short circuit.)
Electrical isolation	from voltage supply yes from the inputs yes from PC interface, memory module, CL-NET, CL-LINK yes
Rated operational current I_e on „1“ signal DC	max. 0.5 A
Lamp load without R_v	5 W (Q1-Q4)
Residual current on „0“ signal per channel	< 0.1 mA
Max. output voltage	on „0“ signal at external load < 10 M Ω 2.5 V on „1“ signal at $I_e = 0.5\text{ A}$ $U = U_e - 1\text{ V}$
Short-circuit protection	thermal (Q1-Q4), (analysis results from diagnosis input I16)
Short-circuit tripping current for $R_a \leq 10\text{ m}\Omega$	$0.7\text{ A} \leq I_e \leq 2\text{ A}$ per output
Total short-circuit current	8 A
Peak short-circuit current	16 A
Thermal tripping	yes
Max. switching frequency with constant resistive load $R_L < 100\text{ k}\Omega$ (depending on active channels and their load)	40.000 switching cycles/h
Parallel connection of outputs	with resistive load, inductive load with external suppressor, combination within one group group 1: Q1-Q4 number of outputs max. 4 max. total current 2 A (Attention! Outputs must be actuated simultaneously and for the same length of time.)
Indication of operational states of the outputs	LCD-Display (if existing)
Inductive load ¹⁾ without external suppressor	
$T_{0.95} = 1\text{ ms}$, $R = 48\ \Omega$, $L = 16\text{ mH}$	utilization factor 0.25 g duty time 100 % max. switching frequency $f = 0.5\text{ Hz}$ 1500 switching cycles (max. duty time = 50 %)
DC13, $T_{0.95} = 72\text{ ms}$, $R = 48\ \Omega$, $L = 1.15\text{ H}$	utilization factor 0.25 g duty time 100 % max. switching frequency $f = 0.5\text{ Hz}$ 1500 switching cycles (max. duty time = 50 %)
$T_{0.95} = 15\text{ ms}$, $R = 48\ \Omega$, $L = 0.24\text{ H}$	utilization factor 0.25 g duty time 100 % max. switching frequency $f = 0.5\text{ Hz}$ 1500 switching cycles (max. duty time = 50 %)
Inductive load ¹⁾ with external suppressor	demand factor 1 g duty time 100 % max. switching frequency max. duty time depends on suppressor

¹⁾ For inductive loading, without external suppression of the transistor outputs, the following applies:
 $T_{0.95}$ = time in ms, until 95 % of the steady-state current is achieved. $T_{0.95} \cdot 3 \times T_{0.65} = 3 \times L/R$.

Data transfer rate in the CL-NET network: bus lengths of 40 m and over only attainable with cables with additional cross-section and connection adapter.

Logic relays

Dimensional drawings

Dimensional drawings

dimensions in mm

CL-LDC.S..

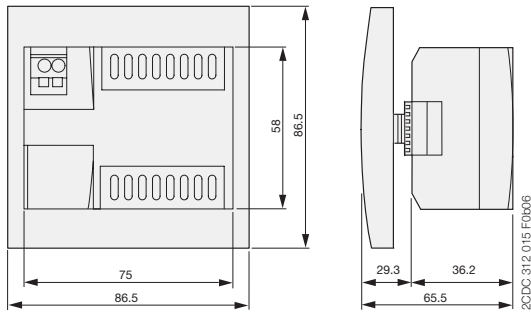

CL-LDD

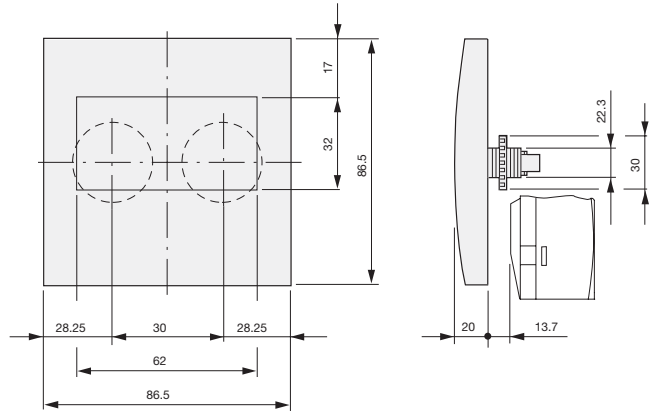

CL-LDD.K + CL-LDC.L.. +
(CL-LDR or CL-LDT)

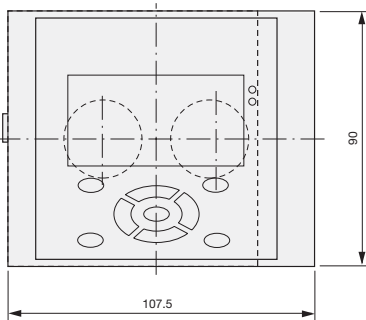

CL-LDR, CL-LDT

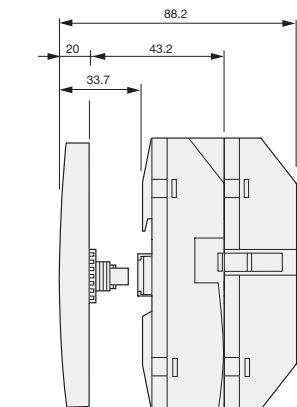
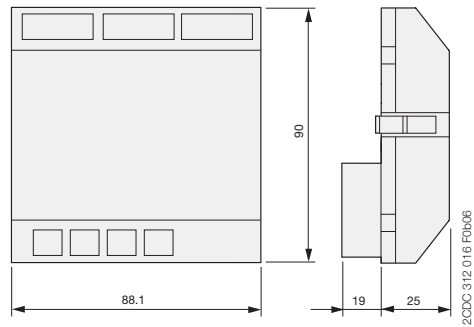

CL-LER.20

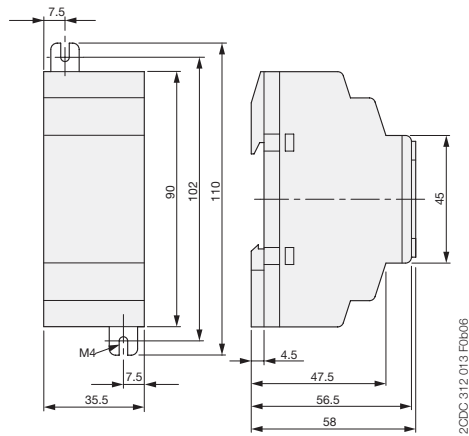

Logic relays

Dimensional drawings

Dimensional drawings

dimensions in mm

CL-LMR, CL-LMT

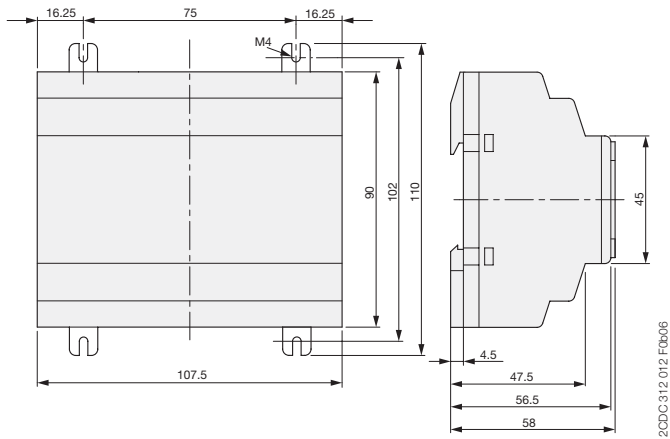

CL-LSR, CL-LST

