

## SCD4x

### Breaking the size barrier in CO<sub>2</sub> sensing



#### Features

- Photoacoustic sensor technology PASens®
- Smallest form factor: 10.1 x 10.1 x 6.5 mm<sup>3</sup>
- Surface-mount device for effective assembly
- Large output range: 0 ppm – 40'000 ppm
- Large supply voltage range: 2.4 – 5.5 V
- High accuracy:  $\pm(40 \text{ ppm} + 5 \%)$
- Digital interface I<sup>2</sup>C with digital output signal
- Integrated temperature and humidity sensor
- Adjustable current-consumption down to < 0.4 mA avg. @ 5 V, 1 meas. / 5 minutes

#### Product Summary

The SCD4x is Sensirion's next generation miniature CO<sub>2</sub> sensor. This sensor builds on the photoacoustic sensing principle and Sensirion's patented PASens® and CMOSens® technology to offer high accuracy at an unmatched price and smallest form factor. SMD assembly allows cost- and space-effective integration of the sensor combined with maximal freedom of design. On-chip signal compensation is realized with the build-in SHT4x humidity and temperature sensor.

CO<sub>2</sub> is a key indicator for indoor air quality as high levels compromise humans' cognitive performance and well-being. The SCD4x enables smart ventilation systems to regulate ventilation in the most energy-efficient and human-friendly way. Moreover, indoor air quality monitors and other connected devices based on the SCD4x can help maintaining low CO<sub>2</sub> concentration for a healthy, productive environment.

#### Device Overview

Products	Details
SCD40-D-R2	Base accuracy, specified range 400 – 2'000 ppm
SCD41-D-R2	High accuracy, specified range 400 – 5'000 ppm, single shot mode supported

Full product list on page 21

#### Functional Block Diagram

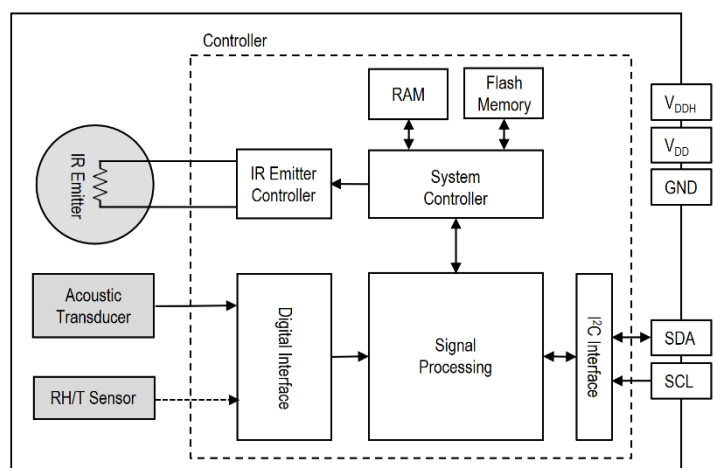

## Table of Contents

<b>1</b>	<b>Sensor Performance</b>	3
1.1	CO <sub>2</sub> Sensing Performance	3
1.2	Humidity Sensing Performance	3
1.3	Temperature Sensing Performance <sup>5</sup>	3
<b>2</b>	<b>Specifications</b>	4
2.1	Electrical Specifications	4
2.2	Absolute Maximum Ratings	4
2.3	Interface Specifications	5
2.4	Timing Specifications	6
2.5	Material Contents	6
<b>3</b>	<b>Digital Interface Description</b>	7
3.1	Power-Up and Communication Start	7
3.2	Data type & length	7
3.3	Command Sequence Types	7
3.4	SCD4x Command Overview	8
3.5	Basic Commands	9
3.6	On-Chip Output Signal Compensation	10
3.7	Field Calibration	12
3.8	Low Power operation	14
3.9	Advanced Features	15
3.10	Low power single shot (SCD41)	17
3.11	Checksum Calculation	18
<b>4</b>	<b>Mechanical specifications</b>	19
4.1	Package Outline	19
4.2	Land Pattern	19
4.3	Tape & Reel Package	20
4.4	Moisture Sensitivity Level	20
4.5	Soldering Instructions	21
4.6	Traceability	21
<b>5</b>	<b>Ordering Information</b>	21
<b>6</b>	<b>Revision History</b>	21

# 1 Sensor Performance

## 1.1 CO<sub>2</sub> Sensing Performance

Default conditions of 25 °C, 50 % RH, 1013 mbar, periodic measurement (i.e. *high performance mode*) and 3.3 V supply voltage apply to values in the table below, unless otherwise stated.

Parameter	Conditions	Value
CO <sub>2</sub> output range <sup>1</sup>	-	0 – 40'000 ppm
SCD40 CO <sub>2</sub> measurement accuracy <sup>2</sup>	400 ppm – 2'000 ppm	± (50 ppm + 5% of reading)
SCD41 CO <sub>2</sub> measurement accuracy <sup>2</sup>	400 ppm – 5'000 ppm	± (40 ppm + 5% of reading)
Repeatability	Typical	± 10 ppm
Response time <sup>3</sup>	τ <sub>63%</sub> , typical	60 s
Accuracy drift per year with automatic self-calibration algorithm enabled <sup>4</sup>	Typical	± (5 ppm + 0.5 % of reading)

**Table 1:** SCD40 and SCD41 CO<sub>2</sub> sensor specifications

## 1.2 Humidity Sensing Performance<sup>5</sup>

Parameter	Conditions	Value
Humidity measurement range	-	0 %RH – 100 %RH
Accuracy (typ.)	15 °C – 35 °C, 20 %RH – 65 %RH	6 % RH
	-10 °C – 60 °C, 0 %RH – 100 %RH	9 % RH
Repeatability	Typical	± 0.4 %RH
Response time <sup>3</sup>	τ <sub>63%</sub> , typical	90 s
Accuracy drift	-	< 0.25 %RH / year

**Table 2:** SCD4x humidity sensor specifications

## 1.3 Temperature Sensing Performance<sup>5</sup>

Parameter	Conditions	Value
Temperature measurement range	-	- 10°C – 60°C
Accuracy (typ.)	15 °C – 35 °C	0.8 °C
	-10 °C – 60 °C	1.5 °C
Repeatability	-	± 0.1°C
Response time <sup>3</sup>	τ <sub>63%</sub> , typical	120 s
Accuracy drift	-	< 0.03 °C / year

**Table 3:** SCD4x temperature sensor specifications

<sup>1</sup> Exposure to CO<sub>2</sub> concentrations smaller than 400 ppm can affect the accuracy of the sensor if the automatic self-calibration (ASC) is on.

<sup>2</sup> Deviation to a high-precision reference. Accuracy is fulfilled by > 90% of the sensors after calibration. Rough handling, shipping and soldering reduces the accuracy of the sensor. Accuracy is restored with FRC or ASC recalibration features. Accuracy is based on tests with gas mixtures having a tolerance of ± 1.5%.

<sup>3</sup> Time for achieving 63% of a respective step function when operating the SCD41 Evaluation Kit with default measurement mode. Response time depends on design-in, signal update rate and environment of the sensor in the final application.

<sup>4</sup> For proper function of ASC field-calibration algorithm SCD4x has to be exposed to air with CO<sub>2</sub> concentration 400 ppm regularly. Maximum accuracy drift per year estimated from stress tests is ± (5 ppm + 2 % of reading). Higher drift values may occur if the sensor is not handled according to its handling instructions.

<sup>5</sup> Design-in of the SCD4x in final application, self-heating of the sensor and the environment impacts the accuracy of the RH/T sensor. To realize indicated specifications, the temperature-offset of the SCD4x inside the customer device must be set correctly (see chapter 3.6). Best RH/T accuracy is realized when operating the SCD4x in low power continuous measurement mode.

## 2 Specifications

### 2.1 Electrical Specifications

Parameter	Symbol	Conditions	Min.	Typical	Max.	Units
Supply voltage DC	$V_{DD}$		2.4		5.5	V
Voltage ripple peak to peak	$V_{RPP}$				30	mV
Peak supply current <sup>6</sup>		$V_{DD} = 3.3\text{ V}$		175	205	mA
		$V_{DD} = 5\text{ V}$		115	137	mA
Average supply current periodic measurement (default mode)	$I_{DD}$	$V_{DD} = 3.3\text{ V}$		15	18	mA
		$V_{DD} = 5\text{ V}$		11	13	mA
Average supply current low power mode	$I_{DD}$	$V_{DD} = 3.3\text{ V}$		3.2	3.5	mA
		$V_{DD} = 5\text{ V}$		2.8	3	mA
Average supply current single shot, 1 measurement / 5 minutes (SCD41 only) <sup>7</sup>	$I_{DD}$	$V_{DD} = 3.3\text{ V}$		0.45	0.5	mA
		$V_{DD} = 5\text{ V}$		0.36	0.4	mA
Input high level voltage	$V_{IH}$		$0.7 \times V_{DD}$		$1 \times V_{DD}$	-
Input low level voltage	$V_{IL}$				$0.3 \times V_{DD}$	-
Output low level voltage	$V_{OL}$	3 mA sink current			0.66	V

**Table 4** SCD4x electrical specifications

### 2.2 Absolute Maximum Ratings

Stress levels beyond those listed in **Table 5** may cause permanent damage to the device. Exposure to minimum/maximum rating conditions for extended periods may affect sensor performance and reliability of the device.

Parameter	Conditions	Value
Temperature operating conditions		-10 – 60°C
Humidity operating conditions <sup>8</sup>	Non-condensing.	0 – 95 %RH
MSL Level		3
DC supply voltage		- 0.3 V – 6.0 V
Max voltage on pins SDA, SCL, GND		- 0.3 V to $V_{DD}+0.3\text{ V}$
Input current on pins SDA, SCL, GND		+/- 100 mA
Short term storage temperature <sup>9</sup>		- 40°C – 70°C
Recommended storage temperature		10 °C – 50 °C
ESD HBM		2 kV
ESD CDM		500 V
Maintenance Interval	Maintenance free when ASC field-calibration algorithm <sup>10</sup> is used.	None
Sensor lifetime <sup>11</sup>	Typical operating conditions	> 10 years

**Table 5:** SCD4x operation conditions, lifetime and maximum ratings

<sup>6</sup> Power supply should be designed with respect to peak current.

<sup>7</sup> On-demand measurement with freely adjustable interval. See chapter 3.10

<sup>8</sup> Accuracy can be reduced at relative humidity levels lower than 10 %.

<sup>9</sup> Short term storage refers to temporary conditions during e.g. transport.

<sup>10</sup> For proper function of ASC field-calibration algorithm the SCD4x has to be exposed to outdoor air with 400 ppm concentration regularly.

<sup>11</sup> Sensor tested over simulated lifetime of > 10 years for indoor environment mission profile

### 2.3 Interface Specifications

The SCD4x comes in an LGA package (**Table 6**). The package outline is schematically displayed in chapter 4.1. The landing pattern of the SCD4x can be found in chapter 4.2.

Name	Comments
VDD	Supply voltage
VDDH	Supply voltage IR source, must be connected to VDD on customer PCB
GND	Ground contact
SDA	I2C Serial data, bidirectional
SCL	I2C Serial clock
DNC	Do not connect, pads must be soldered to a floating pad on the customer PCB

**Table 6** Pin assignment (top view). The notched corner of the protection membrane serves as a polarity mark to indicate pin 1 location.

VDD and VDDH are used to supply the sensor and must always be kept at the same voltage, i.e. should both be connected to the same power supply. The combined maximum current drawn on VDD and VDDH is indicated in **Table 4**. Care should be taken to choose a low noise power supply (preferably a low-dropout regulator, LDO with output ripple of less than 30 mV p-p), which is adequately dimensioned for the relatively large peak currents. Power supply configurations with large transient voltage drops are to be avoided to ensure proper sensor operation.

SCL is used to synchronize the I2C communication between the master (microcontroller) and the slave (sensor). The SDA pin is used to transfer data to and from the sensor. For safe communication, the timing specifications defined in the I<sup>2</sup>C manual<sup>12</sup> must be met. Both SCL and SDA lines should be connected to external pull-up resistors (e.g.  $R_p = 10\text{ k}\Omega$ , see **Figure 1**). To avoid signal contention, the microcontroller must only drive SDA and SCL low. For dimensioning resistor sizes please take bus capacity and communication frequency into account (see example in Section 7.1 of NXP's I<sup>2</sup>C Manual for more details<sup>10</sup>). It should be noted that pull-up resistors may be included in I/O circuits of microcontrollers.

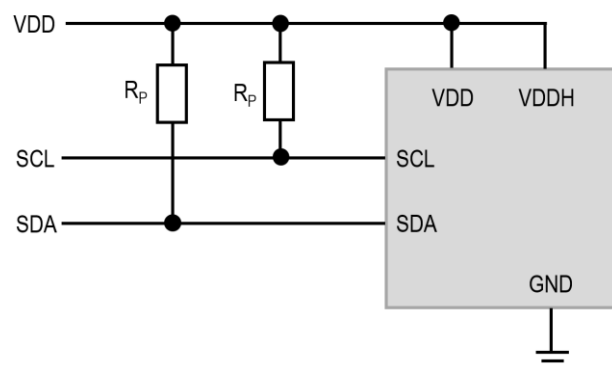

**Figure 1:** Typical application circuit (for better clarity in the image, the positioning of the pins does not reflect the positions on the real sensor). VDD and VDDH must be connected to each other close to the sensor on the customer PCB.

<sup>12</sup> [http://www.nxp.com/documents/user\\_manual/UM10204.pdf](http://www.nxp.com/documents/user_manual/UM10204.pdf)

## 2.4 Timing Specifications

Table 7 list the timings of the ASIC part and does not reflect the availability or usefulness of the sensor readings. The SCD4x supports the I<sup>2</sup>C “standard-mode” as is described elsewhere (see footnote <sup>12</sup>).

Parameter	Condition	Min.	Max.	Unit
Power-up time	After hard reset, $V_{DD} \geq 2.25$ V	-	1000	ms
Soft reset time	After re-initialization (i.e. reinit)	-	1000	ms
SCL clock frequency	-	0	100	kHz

Table 7 System timing specifications.

## 2.5 Material Contents

The device is fully RoHS compliant.

### 3 Digital Interface Description

All SCD4x commands and data are mapped to a 16-bit address space.

SCD4x	Hex. Code
I <sup>2</sup> C address	0x62

**Table 8** I<sup>2</sup>C device address.

#### 3.1 Power-Up and Communication Start

The sensor starts powering-up after reaching the power-up threshold voltage  $V_{DD,Min} = 2.25$  V. After reaching this threshold voltage, the sensor needs 1000 ms to enter the idle state. Once the idle state is entered it is ready to receive commands from the master.

Each transmission sequence begins with a START condition (S) and ends with a STOP condition (P) as described in the I<sup>2</sup>C-bus specification.

#### 3.2 Data type & length

Data sent to and received from the sensor consists of a sequence of 16-bit words (each to be interpreted as unsigned integer, most significant byte transmitted first). Each word is immediately succeeded by an 8-bit CRC. In write direction it is mandatory to transmit the checksum. In read direction it is up to the master to decide if it wants to process the checksum (see chapter 3.11).

#### 3.3 Command Sequence Types

The SCD4x features three different I<sup>2</sup>C command sequence types: *read I<sup>2</sup>C sequences*, *write I<sup>2</sup>C sequences* and *send I<sup>2</sup>C command sequences*. **Figure 2** illustrates how the I<sup>2</sup>C communication for the different sequence types is built-up.

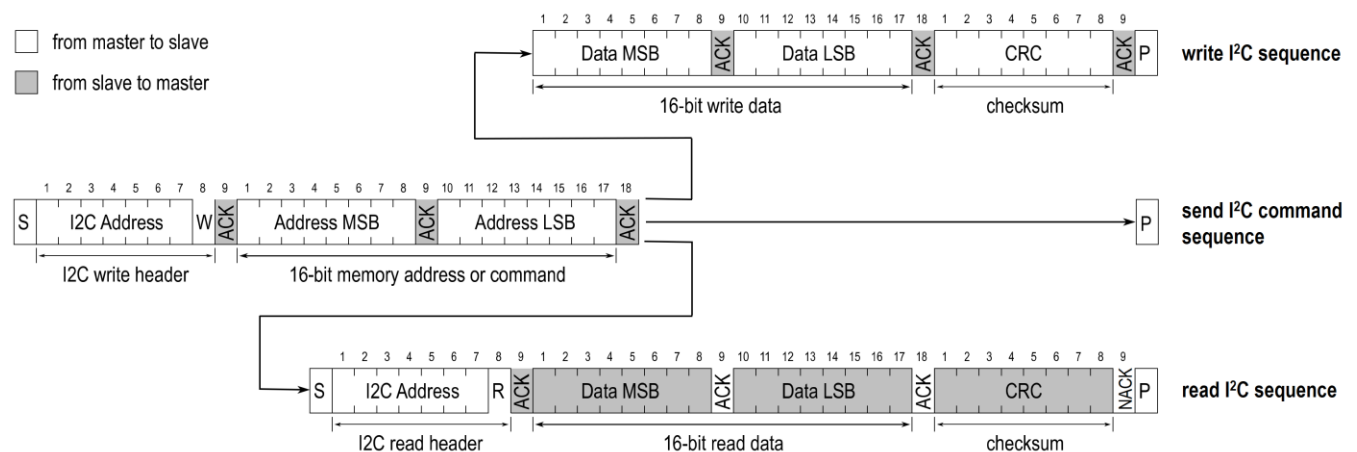

**Figure 2:** Command Sequence types: write sequence, send command sequence and read sequence.

After issuing read sequence commands and sending the ACK Bit the sensor needs the *execution time* (see **Table 9**) to respond to the I<sup>2</sup>C read header with an ACK bit. Hence, it is required to wait the command *execution time* before issuing the read header. Commands must not be sent while a previous command is being processed.

### 3.4 SCD4x Command Overview

**Table 9:** List of SCD4x sensor commands. Detailed description of SCD4x commands can be found further down.

Domain	Command	Hex. Code	I <sup>2</sup> C sequence type (see chapter 3.3)	Execution time [ms]
Basic Commands Chapter 3.5	start_periodic_measurement	0x21b1	send command	-
	read_measurement	0xec05	read	1
	stop_periodic_measurement	0x3f86	send command	500
On-chip output signal compensation Chapter 3.6	set_temperature_offset	0x241d	write	1
	get_temperature_offset	0x2318	read	1
	set_sensor_alititude	0x2427	write	1
	get_sensor_alititude	0x2322	read	1
	set_ambient_pressure	0xe000	write	1
Field calibration Chapter 3.7	perform_forced_recalibration	0x362f	write and read	400
	set_automatic_self_calibration_enabled	0x2416	write	1
	get_automatic_self_calibration_enabled	0x2313	read	1
Low power Chapter 3.8	start_low_power_periodic_measurement	0x21ac	send command	-
	get_data_ready_status	0xe4b8	read	1
Advanced features Chapter 3.9	persist_settings	0x3615	send command	800
	get_serial_number	0x3682	read	1
	perform_self_test	0x3639	read	5500
	perform_factory_reset	0x3632	send command	1200
	reinit	0x3646	send command	20
Low power single shot (SCD41 only) Chapter 3.10	measure_single_shot	0x219d	send command	1350
	measure_single_shot_rht_only	0x2196	send command	50



### 3.5 Basic Commands

This section lists the basic SCD4x commands that are necessary to start a periodic measurement and subsequently read out the sensor outputs.

The typical communication sequence between the I<sup>2</sup>C master (e.g., a microcontroller) and the SCD4x sensor is as follows:

1. The sensor is powered up
2. The I<sup>2</sup>C master sends a *start periodic measurement* command. Signal update interval is 5 seconds.
3. The I<sup>2</sup>C master periodically reads out data with the *read measurement* sequence.
4. To put the sensor back to idle mode, the I<sup>2</sup>C master sends a *stop periodic measurement* command.

While a periodic measurement is running, no other commands must be issued with the exception of *read measurement*, *get data ready status*, *stop periodic measurement* and *set ambient pressure*.

#### 3.5.1 start\_periodic\_measurement

**Description:** start periodic measurement, signal update interval is 5 seconds. The default periodic measurement mode is also referred to as 'high performance mode'.

**Table 10:** start\_periodic\_measurement I<sup>2</sup>C sequence description

Write (hexadecimal)	Input parameter: -		Response parameter: -		Max. command duration [ms]
	length [bytes]	signal conversion	length [bytes]	signal conversion	
0x21b1	-	-	-	-	not applicable
<b>Example:</b> start periodic measurement					
Write (hexadecimal)	0x21b1 Command				

#### 3.5.2 read\_measurement

**Description:** read sensor output. The measurement data can only be read out once per signal update interval as the buffer is emptied upon read-out. If no data is available in the buffer, the sensor returns a NACK. To avoid a NACK response the *get\_data\_ready\_status* can be issued to check data status (see chapter 3.8.2 for further details). The I<sup>2</sup>C master can abort the read transfer with a NACK followed by a STOP condition after any data byte if the user is not interested in subsequent data.

**Table 11:** read\_measurement I<sup>2</sup>C sequence description

Write (hexadecimal)	Input parameter: -			Response parameter: CO <sub>2</sub> , Temperature, Relative Humidity		Max. command duration [ms]
	length [bytes]	signal conversion	length [bytes]	signal conversion		
0xec05	-	-	3	CO <sub>2</sub> [ppm] = word[0]	1	
			3	$T = -45 + 175 * \text{word}[1] / 2^{16}$		
			3	$RH = 100 * \text{word}[2] / 2^{16}$		
<b>Example:</b> read sensor output (500 ppm, 25 °C, 37 % RH)						
Write (hexadecimal)	0xec05 Command					
Wait	1 ms <i>command execution time</i>					
Response (hexadecimal)	0x01f4 CO <sub>2</sub> = 500 ppm	0x7b CRC of 0x01f4	0x6667 Temp. = 25 °C	0xa2 CRC of 0x6667	0x5eb9 RH = 37 %	0x3c CRC of 0x5eb9

### 3.5.3 stop\_periodic\_measurement

**Description:** stop periodic measurement for sensor configuration or to save power.

**Table 12:** stop\_periodic\_measurement I2C sequence description

Write (hexadecimal)	Input parameter: -		Response parameter: -		Max. command duration [ms]
	length [bytes]	signal conversion	length [bytes]	signal conversion	
0x3f86	-	-	-	-	500
<b>Example:</b> stop periodic measurement					
Write (hexadecimal)	0x3f86 Command				

### 3.6 On-Chip Output Signal Compensation

The SCD4x features on-chip signal compensation to counteract pressure and temperature effects. Feeding the SCD4x with the pressure or altitude enables highest accuracy of the CO<sub>2</sub> output signal across a large pressure range. Setting the temperature offset improves the accuracy of the relative humidity and temperature output signal. Note that the temperature offset does not impact the accuracy of the CO<sub>2</sub> output.

To change or read sensor settings, the SCD4x must be in idle mode. A typical sequence between the I<sup>2</sup>C master and the SCD4x is described as follows:

1. If the sensor is operated in a periodic measurement mode, the I<sup>2</sup>C master sends a *stop\_periodic\_measurement* command
2. The I<sup>2</sup>C master sends one or several commands to get or set the sensor settings
3. If configurations shall be preserved after power-cycle events, the *persist\_settings* command is sent (see chapter 3.9.1)
4. The I<sup>2</sup>C master sends a start measurement command to set the sensor in the operating mode again

#### 3.6.1 set\_temperature\_offset

**Description:** The temperature offset has no influence on the SCD4x CO<sub>2</sub> accuracy. Setting the temperature offset of the SCD4x inside the customer device correctly allows the user to leverage the RH and T output signal. Note that the temperature offset can depend on various factors such as the SCD4x measurement mode, self-heating of close components, the ambient temperature and air flow. Thus, the SCD4x temperature offset should be determined inside the customer device under its typical operation and in thermal equilibrium. Per default, the temperature offset is set to 4° C. To save the setting to the EEPROM, the *persist\_setting* (see chapter 3.9.1) command must be issued. Equation (1) shows how the characteristic temperature offset can be obtained.

$$T_{offset\_actual} = T_{SCD40} - T_{Reference} + T_{offset\_previous} \quad (1)$$

**Table 13:** set\_temperature\_offset I2C sequence description

Write (hexadecimal)	Input parameter: Offset temperature			Response parameter: -		Max. command duration [ms]
	length [bytes]	signal conversion		length [bytes]	signal conversion	
0x241d	3	$T_{offset} [^{\circ}C] = 175 * word[0] / 2^{16}$		-	-	1
<b>Example:</b> set temperature offset to 5.4 °C						
Write (hexadecimal)	0x241d Command	0x07e6 $T_{offset} = 5.4^{\circ}C$	0x48 CRC of 0x7e6			

### 3.6.2 get\_temperature\_offset

Table 14: get\_temperature\_offset I2C sequence description

Write (hexadecimal)	Input parameter: -		Response parameter: Offset temperature		Max. command duration [ms]
	length [bytes]	signal conversion	length [bytes]	signal conversion	
0x2318	-	-	3	$T_{\text{offset}} [^{\circ}\text{C}] = 175 * \text{word}[0] / 2^{16}$	1
<b>Example:</b> temperature offset is 6.2 °C					
Write (hexadecimal)	0x2318 Command				
Wait	1 ms	command execution time			
Response (hexadecimal)	0x0912 $T_{\text{offset}} = 6.2 \text{ } ^{\circ}\text{C}$	0x63 CRC of 0x0912			

### 3.6.3 set\_sensor\_altitude

**Description:** Reading and writing of the sensor altitude must be done while the SCD4x is in idle mode. Typically, the sensor altitude is set once after device installation. To save the setting to the EEPROM, the *persist setting* (see chapter 3.9.1) command must be issued. Per default, the sensor altitude is set to 0 meter above sea-level.

Table 15: set\_sensor\_altitude I2C sequence description

Write (hexadecimal)	Input parameter: Sensor altitude		Response parameter: -		Max. command duration [ms]
	length [bytes]	signal conversion	length [bytes]	signal conversion	
0x2427	3	Sensor altitude [m] = word[0]	-	-	1
<b>Example:</b> set sensor altitude to 1'950 m.a.s.l.					
Write (hexadecimal)	0x2427 Command	0x079e Sensor altitude = 1'950 m	0x09 CRC of 0x79e		

### 3.6.4 get\_sensor\_altitude

Table 16: get\_sensor\_altitude I2C sequence description

Write (hexadecimal)	Input parameter: -		Response parameter: Sensor altitude		Max. command duration [ms]
	length [bytes]	signal conversion	length [bytes]	signal conversion	
0x2322	-	-	3	Sensor altitude [m] = word[0]	1
<b>Example:</b> sensor altitude is 1'100 m.a.s.l.					
Write (hexadecimal)	0x2322 Command				
Wait	1 ms	command execution time			
Response (hexadecimal)	0x044c Sensor altitude = 1'100 m	0x42 CRC of 0x044c			

### 3.6.5 set\_ambient\_pressure

**Description:** The *set\_ambient\_pressure* command can be sent during periodic measurements to enable continuous pressure compensation. Note that setting an ambient pressure to the sensor using *set\_ambient\_pressure* overrides any pressure compensation based on a previously set sensor altitude.

**Table 17:** set\_ambient\_pressure I2C sequence description

Write (hexadecimal)	Input parameter: Ambient pressure		Response parameter: -		Max. command duration [ms]
	length [bytes]	signal conversion	length [bytes]	signal conversion	
0xe000	3	Ambient P [Pa] = 100* word[0]	-	-	1
<b>Example:</b> set ambient pressure to 98'700 Pa					
Write (hexadecimal)	0xe000 Command	0x03db Ambient P = 98'700 Pa	0x42 CRC of 0x03db		

## 3.7 Field Calibration

To realize high initial and long-term accuracy, the SCD4x includes two field calibration features. Forced recalibration (FRC) enables restoring highest accuracy with the assistance of a CO<sub>2</sub> reference value immediately. Typically, FRC is applied to compensate for drifts originating from the sensor assembly process or other extensive stresses. Automatic self-calibration (ASC) ensures highest long-term stability of the SCD4x without the need of manual action steps from the user. The automatic self-calibration algorithm is based on the assumption that the sensor is exposed to the atmospheric CO<sub>2</sub> concentration of 400 ppm at least once per week.

### 3.7.1 perform\_forced\_recalibration

**Description:** To successfully conduct an accurate forced recalibration, the following steps need to be carried out:

1. Operate the SCD4x in a periodic measurement mode for > 3 minutes in an environment with homogenous and constant CO<sub>2</sub> concentration.
2. Stop periodic measurement. Wait 500 ms.
3. Subsequently issue the *perform\_forced\_recalibration* command and optionally read out the FRC correction (i.e. the magnitude of the correction).
  - A return value of 0xffff indicates that the forced recalibration failed

Note that the sensor will fail to perform a forced recalibration if it was not operated before sending the command. Please make sure that the sensor is operated at the voltage desired for the application when applying the forced recalibration sequence.

**Table 18:** perform\_forced\_recalibration I2C sequence description

Write (hexadecimal)	Input parameter: Target CO <sub>2</sub> concentration		Response parameter: FRC-correction		Max. command duration [ms]
	length [bytes]	signal conversion	length [bytes]	signal conversion	
0x362f	3	Target concentration [ppm CO <sub>2</sub> ] = word[0]	3	FRC correction [ppm CO <sub>2</sub> ] = word[0] – 0x8000 word[0] = 0xff in case of failed FRC	400
<b>Example:</b> perform forced recalibration, reference CO <sub>2</sub> concentration is 490 ppm					
Write (hexadecimal)	0x362f Command	0x01e0 Input: 490 ppm	0xb4 CRC of 0x01e0		
Wait	400 ms	command execution time			
Response (hexadecimal)	0x7fce Response: - 50 ppm	0x7b CRC of 0x7fce			

### 3.7.2 set\_automatic\_self\_calibration\_enabled

**Description:** Set the current state (enabled / disabled) of the automatic self-calibration. By default, ASC is enabled. To save the setting to the EEPROM, the *persist setting* (see chapter 3.9.1) command must be issued.

**Table 19:** set\_automatic\_self\_calibration\_enabled I2C sequence description.

Write (hexadecimal)	Input parameter: ASC enabled		Response parameter: -		Max. command duration [ms]
	length [bytes]	signal conversion	length [bytes]	signal conversion	
0x2416	3	word[0] = 1 → ASC enabled word[0] = 0 → ASC not enabled	-	-	1
<b>Example:</b> set automatic self-calibration status: enabled					
Write (hexadecimal)	0x2416 Command	0x0001 ASC enabled	0xB0 CRC of 0x0001		

### 3.7.3 get\_automatic\_self\_calibration\_enabled

**Table 20:** get\_automatic\_self\_calibration\_enabled I2C sequence description

Write (hexadecimal)	Input parameter: -		Response parameter: ASC enabled		Max. command duration [ms]
	length [bytes]	signal conversion	length [bytes]	signal conversion	
0x2313	-	-	3	word[0] = 1 → ASC enabled word[0] = 0 → ASC disabled	1
<b>Example:</b> read automatic self-calibration status: disabled					
Write (hexadecimal)	0x2313 Command				
Wait	1 ms	command execution time			
Response (hexadecimal)	0x0000 ASC disabled	0x81 CRC of 0x0000			

### 3.8 Low Power operation

To enable use-cases with a constrained power-budget, the SCD4x features a low power continuous measurement mode with signal update interval of 30 seconds. While the low power mode saves power and reduces self-heating of the sensor, the low power continuous measurement mode has a longer response time.

The low power continuous measurement mode is initiated and read-out in a similar manner as the default periodic measurement. Please consult chapter 3.5.2 for further instructions. To avoid NACK when reading the SCD4x output signals, the `get_data_ready_status` command can be used to check whether new measurement data is available for read-out.

#### 3.8.1 start\_low\_power\_periodic\_measurement

**Description:** start low power periodic measurement, signal update interval is 30 seconds.

**Table 21:** start\_low\_power\_periodic\_measurement I2C sequence description

Write (hexadecimal)	Input parameter: -		Response parameter: -		Max. command duration [ms]
	length [bytes]	signal conversion	length [bytes]	signal conversion	
0x21ac	-	-	-	-	not applicable
<b>Example:</b> start low power periodic measurement					
Write (hexadecimal)	0x21ac Command				

#### 3.8.2 get\_data\_ready\_status

**Table 22:** get\_data\_ready\_status I2C sequence description

Write (hexadecimal)	Input parameter: -		Response parameter: data ready status		Max. command duration [ms]
	length [bytes]	signal conversion	length [bytes]	signal conversion	
0xe4b8	-	-	3	If 'last 11 bits are 0' → data not ready else → data ready for read-out	1
<b>Example:</b> read data ready status: data not ready					
Write (hexadecimal)	0xe4b8 Command				
Wait	1 ms <i>command execution time</i>				
Response (hexadecimal)	0x8000 Last 11 bits are 0 → data not ready		0xa2 CRC of 0x8000		

### 3.9 Advanced Features

#### 3.9.1 persist\_settings

**Description:** Configuration settings such as the temperature offset, sensor altitude and the ASC enabled/disabled parameter are by default stored in the volatile memory (RAM) only and will be lost after a power-cycle or when using the power\_down command. The persist\_settings command stores the current configuration in the EEPROM of the SCD4x, making them persistent across power-cycling. To avoid unnecessary wear of the EEPROM, the persist\_settings command should only be sent when persistence is required and if actual changes to the configuration have been made (the EEPROM is guaranteed to endure at least 2000 write cycles before failure). Note that field calibration history (i.e. FRC and ASC, see chapter 3.7) is automatically stored in a separate EEPROM dimensioned for the specified sensor lifetime.

**Table 23:** persist\_settings I2C sequence description

Write (hexadecimal)	Input parameter: -		Response parameter: -		Max. command duration [ms]
	length [bytes]	signal conversion	length [bytes]	signal conversion	
0x3615	-	-	-	-	800
<b>Example:</b> persist settings					
Write (hexadecimal)	0x3615 Command				

#### 3.9.2 get\_serial\_number

**Description:** Reading out the serial number can be used to identify the chip and to verify the presence of the sensor. The get serial number command returns 3 words, and every word is followed by an 8-bit CRC checksum. Together, the 3 words constitute a unique serial number with a length of 48 bits (big endian format).

**Table 24:** get\_serial\_number I2C sequence description

Write (hexadecimal)	Input parameter: -			Response parameter: serial number		Max. command duration [ms]
	length [bytes]	signal conversion	length [bytes]	signal conversion		
0x3682	-	-	9	Serial number = word[0] << 32   word[1] << 16   word[2]	1	
<b>Example:</b> serial number is 273'325'796'834'238						
Write (hexadecimal)	0x3682 Command					
Wait	1 ms <i>command execution time</i>					
Response (hexadecimal)	0xf896 word[0]	0x31 CRC of 0xf896	0x9f07 word[1]	0xc2 CRC of 0x9f07	0x3bbe word[2]	0x89 CRC of 0x3bbe

### 3.9.3 perform\_self\_test

**Description:** The perform\_self\_test feature can be used as an end-of-line test to confirm sensor functionality and the customer power supply to the sensor.

**Table 25:** perform\_self\_test I2C sequence description

Write (hexadecimal)	Input parameter: -		Response parameter: sensor status		Max. command duration [ms]
	length [bytes]	signal conversion	length [bytes]	signal conversion	
0x3639	-	-	3	word[0] = 0 → no malfunction detected word[0] ≠ 0 → malfunction detected	5500
<b>Example:</b> perform self-test, no malfunction detected					
Write (hexadecimal)	0x3639 Command				
Wait	5500 ms <i>command execution time</i>				
Response (hexadecimal)	0x0000 <i>No malfunction detected</i>		0x81 <i>CRC of 0x0000</i>		

### 3.9.4 perform\_factory\_reset

**Description:** The perform\_factory\_reset command resets all configuration settings stored in the EEPROM and erases the FRC and ASC algorithm history.

**Table 26:** perform\_factory\_reset I2C sequence description

Write (hexadecimal)	Input parameter: -		Response parameter: -		Max. command duration [ms]
	length [bytes]	signal conversion	length [bytes]	signal conversion	
0x3632	-	-	-	-	1200
<b>Example:</b> perform factory reset					
Write (hexadecimal)	0x3632 Command				

### 3.9.5 reinit

**Description:** The reinit command reinitializes the sensor by reloading user settings from EEPROM. Before sending the reinit command, the stop measurement command must be issued. If reinit command does not trigger the desired re-initialization, a power-cycle should be applied to the SCD4x.

**Table 27:** reinit I2C sequence description

Write (hexadecimal)	Input parameter: -		Response parameter: -		Max. command duration [ms]
	length [bytes]	signal conversion	length [bytes]	signal conversion	
0x3646	-	-	-	-	20
<b>Example:</b> reinit					
Write (hexadecimal)	0x3646 Command re-initialization				



### 3.10 Low power single shot (SCD41)

In addition to continuous measurement modes, the SCD41 features single shot measurement (i.e. on-demand measurement). The typical communication sequence between the I<sup>2</sup>C master and the SCD41 sensor is as follows:

1. The sensor is powered up
2. The I<sup>2</sup>C master sends a single shot command and waits for the indicated *max. command duration* time
3. The I<sup>2</sup>C master reads out data with the *read measurement* sequence (chapter 3.5.2).

To reduce noise-levels, the I<sup>2</sup>C master can perform several single shot measurements and average of the CO<sub>2</sub> output values. Same as with the continuous measurement modes, the automatic self-calibration (ASC) is enabled per default. The automatic self-calibration is optimized for a measurement interval of 5 minutes. Longer measurement interval will result in less frequent self-calibration sequences. Please consult Chapter 3.7 for further description on the automatic-self calibration and the corresponding commands.

#### 3.10.1 measure\_single\_shot

**Description:** On-demand measurement of CO<sub>2</sub> concentration, relative humidity and temperature. The sensor output is read with the *read\_measurement* command (chapter 3.5.2).

**Table 28:** measure\_single\_shot I<sup>2</sup>C sequence description

Write (hexadecimal)	Input parameter: -		Response parameter: -		Max. command duration [ms]
	length [bytes]	signal conversion	length [bytes]	signal conversion	
0x219d	-	-	-	-	1350
<b>Example:</b> measure single shot					
Write (hexadecimal)	0x219d Command				

#### 3.10.2 measure\_single\_shot\_rht\_only

**Description:** On-demand measurement of relative humidity and temperature only. The sensor output is read with the *read\_measurement* command (chapter 3.5.2). CO<sub>2</sub> output is returned as 0 ppm.

**Table 29:** measure\_single\_shot\_rht\_only I<sup>2</sup>C sequence description

Write (hexadecimal)	Input parameter: -		Response parameter: -		Max. command duration [ms]
	length [bytes]	signal conversion	length [bytes]	signal conversion	
0x2196	-	-	-	-	50
<b>Example:</b> measure single shot, RH and T output only					
Write (hexadecimal)	0x2196 Command				

### 3.11 Checksum Calculation

The 8-bit CRC checksum transmitted after each data word is generated by a CRC algorithm. Its properties are displayed in **Table 30**. The CRC covers the contents of the two previously transmitted data bytes. To calculate the checksum only these two previously transmitted data bytes are used. Note that command words are not followed by CRC.

Property	Value	Example code (C/C++)
Name	CRC-8	<pre> #define CRC8_POLYNOMIAL 0x31 #define CRC8_INIT 0xFF  uint8_t sensirion_common_generate_crc(const uint8_t* data, uint16_t count) {     uint16_t current_byte;     uint8_t crc = CRC8_INIT;     uint8_t crc_bit;     /* calculates 8-Bit checksum with given polynomial */     for (current_byte = 0; current_byte &lt; count; ++current_byte) {         crc ^= (data[current_byte]);         for (crc_bit = 8; crc_bit &gt; 0; --crc_bit) {             if (crc &amp; 0x80)                 crc = (crc &lt;&lt; 1) ^ CRC8_POLYNOMIAL;             else                 crc = (crc &lt;&lt; 1);         }     }     return crc; } </pre>
Width	8 bit	
Protected Data	read and/or write data	
Polynomial	0x31 ( $x^8 + x^5 + x^4 + 1$ )	
Initialization	0xFF	
Reflect input	False	
Reflect output	False	
Final XOR	0x00	
Examples	CRC (0xBEEF) = 0x92	

**Table 30** I<sup>2</sup>C CRC properties.

## 4 Mechanical specifications

### 4.1 Package Outline

Figure 3 schematically displays the package outline. The notched corner of the protection membrane serves as a polarity mark to indicate pin 1 location. Nominal dimensions and tolerances are listed in Table 31.

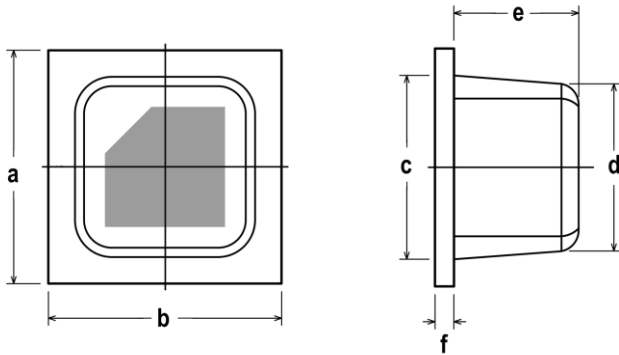

**Figure 3:** Packaging outline drawing of the SCD4x: (left) top view and (right) side view. Nominal dimensions and tolerances are listed in millimeters.

Dimension	a	b	c	d	e	f
Nominal [mm]	10.1	10.1	8.5	7.8	5.5	0.8
Tolerance [mm]	± 0.3	± 0.3	± 0.2	± 0.2	± 0.3	± 0.2

**Table 31:** Nominal dimensions and tolerances SCD4x (all in mm). The weight of the sensor is approx. 0.6 g.

Note that the white protection membrane on top of the sensor must not be removed or tampered with to ensure proper sensor operation.

### 4.2 Land Pattern

Recommended land pattern, solder paste and solder mask are shown in Figure 4.

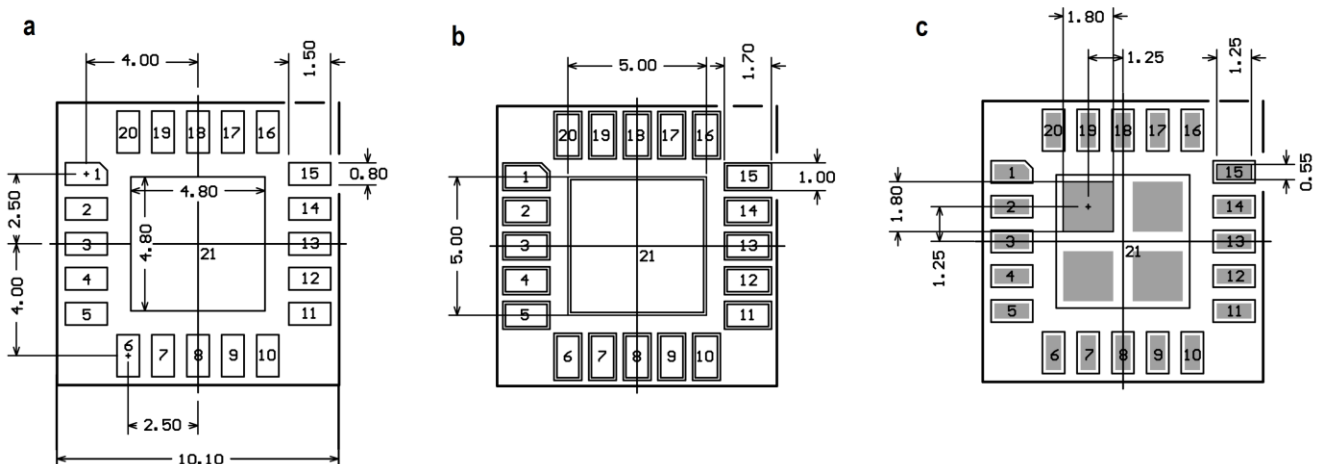

**Figure 4:** SCD4x Footprint (top view): landing pads (a), solder mask (b) and solder paste (c).

### 4.3 Tape & Reel Package

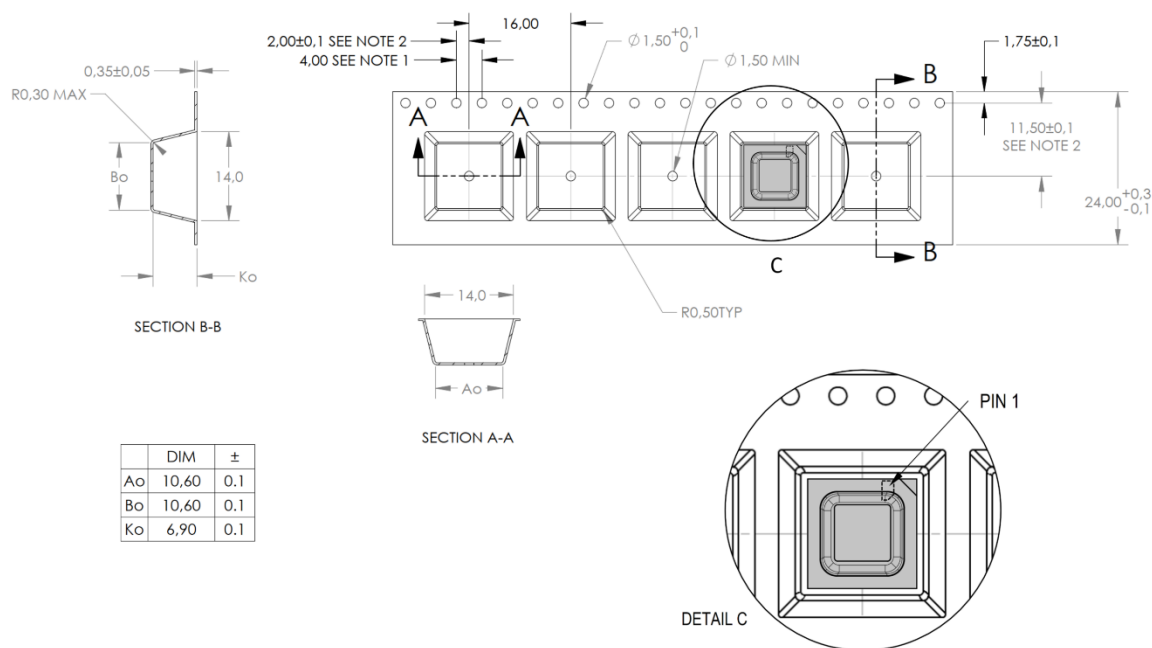

**Figure 5:** Technical drawing of the packaging tape with sensor orientation in tape. Header tape is to the right and trailer tape to the left on this drawing. Dimensions are given in millimeters.

### 4.4 Moisture Sensitivity Level

Sensirion SCD4x sensors shall be treated according to Moisture Sensitivity Level 3 (MSL3) as described in IPC/JEDEC J-STD-033B1. Exposure to moisture levels or solder reflow temperatures, which exceed the limits as stated in this document, can result in yield loss and reliability degradation.

The manufacturing floor time (out of bag) at the customer's end is 168 hours at normal factory conditions ( $\leq 30^\circ\text{C}$  and 60%RH). If sensors are not mounted within this time, or have been exposed to higher temperatures and humidity ( $> 30^\circ\text{C}$  and  $> 60\%RH$ ), or there is any doubt about the airtight integrity of the dry pack, the parts should be baked (baking parameters see **Table 32**). The maximum allowed baking temperature is  $40^\circ\text{C}$  if the sensors are inside the reel.

**Table 32:** Baking condition SCD4x if floor time (168 h) with open bag is exceeded.

SCD4x package type	Baking temperature	Min. baking time	Baking condition
Sensors removed from tape	90 °C	48 hours	RH < 5 %
Sensors in tape	40 °C	23 days	RH < 5 %

## 4.5 Soldering Instructions

For soldering, standard reflow soldering ovens may be used. The sensors are designed to withstand soldering profile according to IPC/JEDEC J-STD-020 with a maximum peak temperature of 235°C during up to 30 sec for Pb-free assembly in IR/Convection reflow ovens.

Note that due to the comparably large size of the SCD4x sensor significant temperature differences across the sensor element can occur during reflow soldering. Specifically, the temperature within the sensor cap can be higher than the temperature measured at the pad using usual temperature monitoring methods. Care must be taken that a temperature of 235° C is not exceeded at any time in any part of the sensor.

Do not apply any board wash process step subsequently to the reflow soldering. Note that the dust cover on top of the cap must not be removed or wetted with any liquid. Finally, the SCD4x is not compatible with vapor phase reflow soldering.

Average ramp-up rate	< 3 °C / second	
Liquid phase	<ul style="list-style-type: none"> <li>▪ <math>T_L</math> &lt; 220 °C</li> <li>▪ <math>t_L</math> &lt; 60 seconds</li> </ul>	
Peak temperature	<ul style="list-style-type: none"> <li>▪ <math>T_P</math> = 235 °C</li> <li>▪ <math>t_P</math> &lt; 30 seconds</li> </ul>	
Ramp-down rate	< 4 °C / seconds for temperature > $T_L$	

**Table 33** Soldering profile parameter

## 4.6 Traceability

All SCD4x sensors have a distinct electronic serial number for identification and traceability (see chapter 3.9.2). The serial number can be decoded by Sensirion only and allows for tracking through production, calibration, and testing.

## 5 Ordering Information

Use the part names and product numbers shown in the following table when ordering the SCD4x CO<sub>2</sub> sensor. For the latest product information and local distributors, visit <http://www.sensirion.com/>.

Part Name	Description	Ordering quantity (pcs)	Product Number
SCD40-D-R2	SCD40 CO2 sensor SMD component as reel, I2C	600 sensors per reel	3.000.521
SCD40-D-R1	SCD40 CO2 sensor SMD component as reel, I2C	60 sensors per reel	3.000.496
SCD41-D-R2	SCD41 CO2 sensor SMD component as reel, I2C	600 sensors per reel	3.000.498
SCD41-D-R1	SCD41 CO2 sensor SMD component as reel, I2C	60 sensors per reel	3.000.497
SEK-SCD41-Sensor	SEK-SCD41-Sensor set; SCD41 on development board with cables	1	3.000.455
SEK-SensorBridge	Sensor Bridge to connect SEK-SCD41-Sensor to computer	1	3.000.124

**Table 34** SCD4x ordering options

## 6 Revision History

Date	Version	Page(s)	Changes
January 2021	1	all	Initial release

## Important Notices

### Warning, Personal Injury

**Do not use this product as safety or emergency stop devices or in any other application where failure of the product could result in personal injury. Do not use this product for applications other than its intended and authorized use. Before installing, handling, using or servicing this product, please consult the data sheet and application notes. Failure to comply with these instructions could result in death or serious injury.**

If the Buyer shall purchase or use SENSIRION products for any unintended or unauthorized application, Buyer shall defend, indemnify and hold harmless SENSIRION and its officers, employees, subsidiaries, affiliates and distributors against all claims, costs, damages and expenses, and reasonable attorney fees arising out of, directly or indirectly, any claim of personal injury or death associated with such unintended or unauthorized use, even if SENSIRION shall be allegedly negligent with respect to the design or the manufacture of the product.

### ESD Precautions

The inherent design of this component causes it to be sensitive to electrostatic discharge (ESD). To prevent ESD-induced damage and/or degradation, take customary and statutory ESD precautions when handling this product.

See application note "ESD, Latchup and EMC" for more information.

### Warranty

SENSIRION warrants solely to the original purchaser of this product for a period of 12 months (one year) from the date of delivery that this product shall be of the quality, material and workmanship defined in SENSIRION's published specifications of the product. Within such period, if proven to be defective, SENSIRION shall repair and/or replace this product, in SENSIRION's discretion, free of charge to the Buyer, provided that:

- notice in writing describing the defects shall be given to SENSIRION within fourteen (14) days after their appearance;
- such defects shall be found, to SENSIRION's reasonable satisfaction, to have arisen from SENSIRION's faulty design, material, or workmanship;
- the defective product shall be returned to SENSIRION's factory at the Buyer's expense; and
- the warranty period for any repaired or replaced product shall be limited to the unexpired portion of the original period.

This warranty does not apply to any equipment which has not been installed and used within the specifications recommended by SENSIRION for the intended and proper use of the equipment. EXCEPT FOR THE WARRANTIES EXPRESSLY SET FORTH HEREIN, SENSIRION MAKES NO WARRANTIES, EITHER EXPRESS OR IMPLIED, WITH RESPECT TO THE PRODUCT. ANY AND ALL WARRANTIES, INCLUDING WITHOUT LIMITATION, WARRANTIES OF MERCHANTABILITY OR FITNESS FOR A PARTICULAR PURPOSE, ARE EXPRESSLY EXCLUDED AND DECLINED.

SENSIRION is only liable for defects of this product arising under the conditions of operation provided for in the data sheet and proper use of the goods. SENSIRION explicitly disclaims all warranties, express or implied, for any period during which the goods are operated or stored not in accordance with the technical specifications.

SENSIRION does not assume any liability arising out of any application or use of any product or circuit and specifically disclaims any and all liability, including without limitation consequential or incidental damages. All operating parameters, including without limitation recommended parameters, must be validated for each customer's applications by customer's technical experts. Recommended parameters can and do vary in different applications.

SENSIRION reserves the right, without further notice, (i) to change the product specifications and/or the information in this document and (ii) to improve reliability, functions and design of this product.

Copyright © 2021, by SENSIRION. CMOSens® is a trademark of Sensirion. All rights reserved

## Headquarters and Subsidiaries

### Sensirion AG

Laubisruetistr. 50  
CH-8712 Staefa ZH  
Switzerland

phone: +41 44 306 40 00  
fax: +41 44 306 40 30  
[info@sensirion.com](mailto:info@sensirion.com)  
[www.sensirion.com](http://www.sensirion.com)

### Sensirion Taiwan Co. Ltd

phone: +886 3 5506701  
[info@sensirion.com](mailto:info@sensirion.com)  
[www.sensirion.com](http://www.sensirion.com)

### Sensirion Inc., USA

phone: +1 312 690 5858  
[info-us@sensirion.com](mailto:info-us@sensirion.com)  
[www.sensirion.com](http://www.sensirion.com)

### Sensirion Japan Co. Ltd.

phone: +81 3 3444 4940  
[info-jp@sensirion.com](mailto:info-jp@sensirion.com)  
[www.sensirion.com/jp](http://www.sensirion.com/jp)

### Sensirion Korea Co. Ltd.

phone: +82 31 337 7700~3  
[info-kr@sensirion.com](mailto:info-kr@sensirion.com)  
[www.sensirion.com/kr](http://www.sensirion.com/kr)

### Sensirion China Co. Ltd.

phone: +86 755 8252 1501  
[info-cn@sensirion.com](mailto:info-cn@sensirion.com)  
[www.sensirion.com/cn](http://www.sensirion.com/cn)

To find your local representative, please visit [www.sensirion.com/distributors](http://www.sensirion.com/distributors)