



Chip type, Ultra High Temperature Series



- High temperature range, for 150°C use
- Complied to the RoHS directive

Item	Characteristics				
Operating temperature range	-55 ~ +150°C				
Leakage current max.	$I = 0.05CV$				
Capacitance tolerance	±20% at 120Hz, 20°C				
Dissipation factor max. (at 120Hz, 20°C)	WV	25	35	50	63
	tanδ	0.16	0.16	0.16	0.16
Low temperature characteristics (Impedance ratio at 100kHz)	$Z (-25°C) / Z (+20°C) \leq 1.5$ $Z (-55°C) / Z (+20°C) \leq 2.0$				
Load life	After an application of DC bias voltage plus the rated AC ripple current for 1000 hours at 150°C. The measurement shall meet the following limits. The DC voltage plus the peak AC voltage combined must not exceed the rated voltage.				
	Capacitance change	Within ±30% of initial value			
	tanδ	Less than 200% of the specified value			
	ESR	Less than 200% of the specified value			
	Leakage current	Less than specified value			
Shelf life(at 125°C)	After 1000 hours no load test, leakage current, capacitance and tanδ are same as load life value. The measurement shall be performed at 20°C by the KS C IEC 60384 - 4				
Resistance to soldering heat	The following specifications shall be satisfied when the capacitors are restored to 20°C after exposing them at 250°C for 10 seconds.				
	Leakage current	Less than specified value			
	Capacitance change	Within ±10% of initial value			
	tanδ	Less than specified value			

DRAWING

Unit : mm

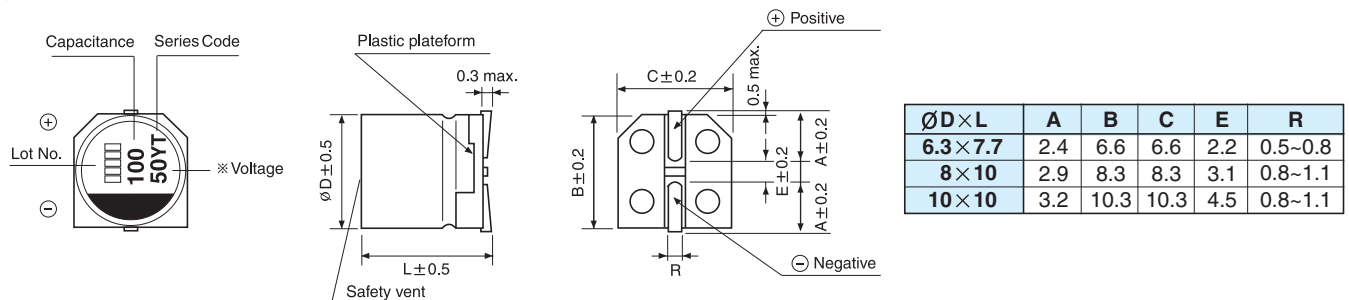

DIMENSIONS & MAXIMUM PERMISSIBLE RIPPLE CURRENT

μF	WV	25		35			50			63		
		15										
22							6.3×7.7	80	410	6.3×7.7	80	410
33										8×10	40	610
47				6.3×7.7	60	510						
56							8×10	35	660	10×10	30	710
68	6.3×7.7	45	540									
100				8×10	30	710	10×10	28	780			
150	8×10	27	740	10×10	23	830						
270	10×10	22	850									

Ripple current (mA rms) at 150°C, 100kHz
 ESR (Ω) at 20°C, 100kHz
 Case size ØD×L(mm)

FREQUENCY COEFFICIENT OF PERMISSIBLE RIPPLE CURRENT

Frequency	120Hz	1kHz	10kHz	100kHz
Coefficient	0.05	0.30	0.70	1.00