

GPS & GLONASS Receiver Module

1. Product Information

1.1 Product Name: YIC51612EBGG-33



1.2 Product Description

YIC51612EBGG-33 features high sensitivity, low power and ultra small form factor. The module is powered by MediaTek. It can provide you with superior sensitivity and performance even in urban canyon and dense foliage environment. The miniature size makes the module easy to integrate into portable device like mobile phone, PDAs, camera and vehicle locators.

This module supports hybrid ephemeris prediction to achieve faster cold start. One is self-generated ephemeris prediction that is no need of both network assistance and host CPU's intervention. This is valid for up to 3 days and updates automatically from time to time when GPS module is powered on and satellites are available. The other is server-generated ephemeris prediction that gets from an internet server. This is valid for up to 14 days. Both ephemeris predictions are stored in the on-board flash memory and perform a cold start time less than 15 seconds.

YIC51612EBGG-33 is suitable for the following applications:

- Automotive navigation
- Personal positioning
- Fleet management
- Mobile phone navigation
- Marine navigation

1.3 Product Features

- MediaTek high sensitivity solution
- Support 99-channel GPS (33 Tracking, 99 Acquisition)
- Ultra low power consumption
- Fast TTFF at low signal level
- Built-in 12 multi-tone active interference canceller
- Free hybrid ephemeris prediction to achieve faster cold start
- Built-in data logger
- Built-in DC/DC converter to save power
- Up to 10 Hz update rate
- ± 1 ns high accuracy time pulse (1PPS)
- Capable of SBAS (WAAS, EGNOS, MSAS, GAGAN)
- Support Japan QZSS
- Indoor and outdoor multi-path detection and compensation
- Small form factor 16.0 * 12.2 * 2.2 mm
- SMD type with stamp holes
- RoHS compliant

1.4 Product Specifications

GNSS Performance

| GNSS Receiver | | |
|-------------------------|---|---|
| Chip | MediaTek MT3333 | |
| Frequency | GPS, GALILEO, QZSS: L1 1575.42MHz, C/A code GLONASS: L1 1598.0625MHz ~ 1605.375MHz, C/A code | |
| Channels | Support 99 channels (33 Tracking, 99 Acquisition) | |
| Update rate | 1Hz default, up to 10Hz | |
| Sensitivity | Tracking | -161dBm, up to -165dBm (with external LNA) |
| | Cold start | -142.5dBm, up to -148dBm (with external LNA) |
| Acquisition Time | Hot start (Open Sky) | < 1s |
| | Cold Start (Open Sky) | < 33s |
| | | < 15s with AGPS |
| Position Accuracy | Autonomous | 3m (2D RMS). |
| | SBAS | 2.5m (depends on accuracy of correction data). |
| Max. Altitude | < 18,000 m, up to 50,000m by request | |
| Max. Velocity | Velocity < 515 m/s | |
| Protocol Support | NMEA 0183 | 9600 bps, 8 data bits, no parity, 1 stop bits (default) |
| | | 1Hz: GGA, GLL, GSA, GSV, RMC, VTG |
| Physical Characteristic | | |
| Dimensions | 16.0mm * 12.2 mm * 2.2mm ±0.2mm | |

1.5 DC Electrical Characteristics

| Parameter | Symbol | Conditions | Min. | Typ. | Max. | Units |
|------------------------------|------------------|---|------|--------------------------------|--------------------|----------------------|
| Input Voltage | VCC | | 3.0 | 3.3 | 4.3 | V |
| Input Backup Battery Voltage | V_BCKP | | 2.0 | | 4.3 | V |
| Supply Current | I _{ss} | VCC = 3.3V, w/o active antenna, Peak Acquisition Tracking Standby | | 31 24 ⁽²⁾ 600 | 150 ⁽¹⁾ | mA mA mA uA |
| Backup Battery Current | I _{bat} | VCC = 0V | | 7 | | uA |
| High Level Input Voltage | V _{IH} | | 2.0 | | 3.6 | V |
| Low Level Input Voltage | V _{IL} | | -0.3 | | 0.8 | V |
| High Level Input Current | I _{IH} | no pull-up or down | -1 | | 1 | uA |
| Low Level Input Current | I _{IL} | no pull-up or down | -1 | | 1 | uA |
| High Level Output Voltage | V _{OH} | | 2.4 | | 3.3 | V |
| Low Level Output Voltage | V _{OL} | | | | 0.4 | V |
| High Level Output Current | I _{OH} | | | 2 | | mA |
| Low Level Output Current | I _{OL} | | | 2 | | mA |

Note 1: This happens when downloading AGPS data to XBDM-1612.

Note 2: Measured when position fix (1Hz) is available, input voltage is 3.3V and the function of self-generated ephemeris prediction is inactive.

Temperature characteristics

| Parameter | Symbol | Min. | Typ. | Max. | Units |
|-----------------------|------------------|------|------|------|-------|
| Operating Temperature | T _{opr} | -40 | 25 | 85 | °C |
| Storage Temperature | T _{stg} | -40 | 25 | 85 | °C |

2. Block Diagram

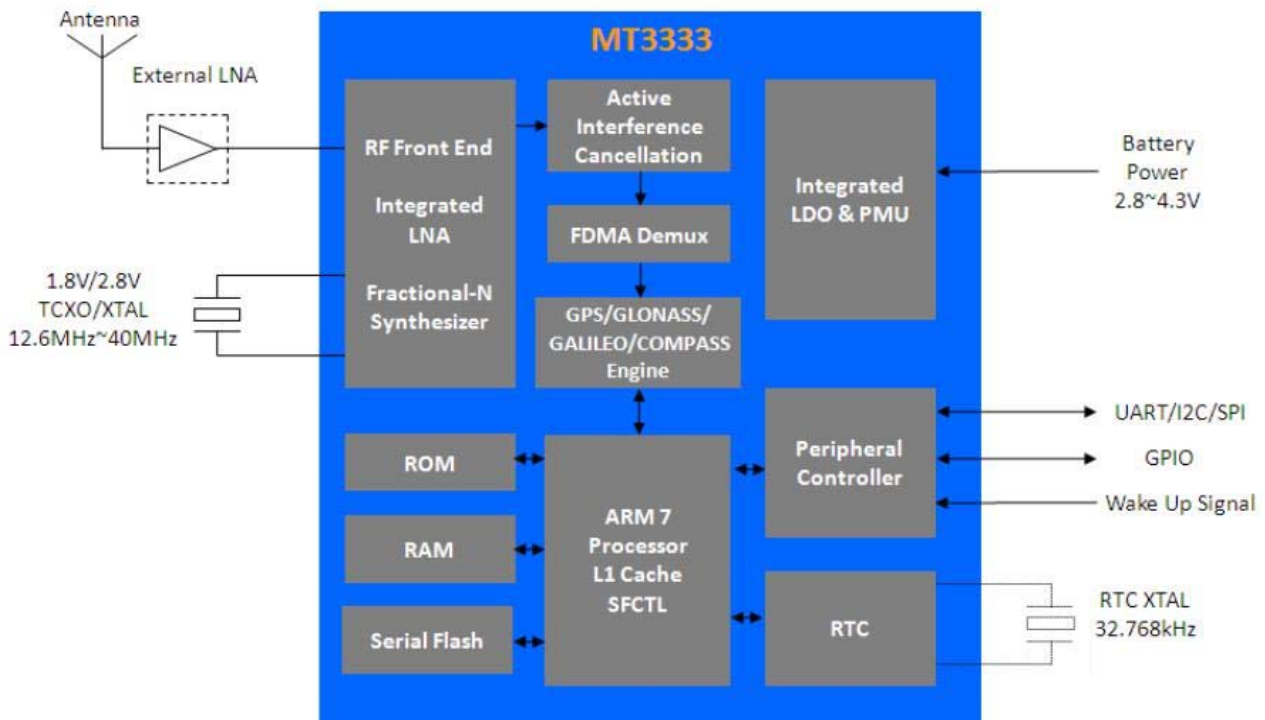

3. Module Pin Assignment

| | | | |
|----|-------|-----------|----|
| 13 | GND | GND | 12 |
| 14 | NC | RF_IN | 11 |
| 15 | NC | GND | 10 |
| 16 | NC | RF_VCC | 9 |
| 17 | NC | NC | 8 |
| 18 | NC | NC | 7 |
| 19 | NC | NC | 6 |
| 20 | TXD | NC | 5 |
| 21 | RXD | NC | 4 |
| 22 | V_BAT | TIMEPULSE | 3 |
| 23 | VCC | NC | 2 |
| 24 | GND | NC | 1 |

| Pin NO. | Pin Name | I/O | Remark |
|---------|-----------|-----|--|
| 1. | NC | N | Not Connect |
| 2. | NC | N | Not Connect |
| 3. | TIMEPULSE | I/O | One pulse per second. |
| 4. | NC | N | Not Connect |
| 5. | NC | N | Not Connect |
| 6. | NC | N | Not Connect |
| 7. | NC | N | Not Connect |
| 8. | NC | N | Not Connect |
| 9. | RF_VCC | O | Output voltage for active antenna |
| 10. | GND | G | Ground. |
| 11. | RF_IN | I | GNSS Signal Input |
| 12. | GND | G | Ground. |
| 13. | GND | G | Ground. |
| 14. | NC | N | Not Connect |
| 15. | NC | N | Not Connect |
| 16. | NC | N | Not Connect |
| 17. | NC | N | Not Connect |
| 18. | NC | N | Not Connect |
| 19. | NC | N | Not Connect |
| 20. | TXD | O | Serial output (Default NMEA) |
| 21. | RXD | I | Serial input (Default NMEA) |
| 22. | V_BAT | P | Backup battery supply voltage This pin must be powered to enable the module. |
| 23. | VCC | P | DC supply voltage |
| 24. | GND | G | Ground. |

4. Dimensions

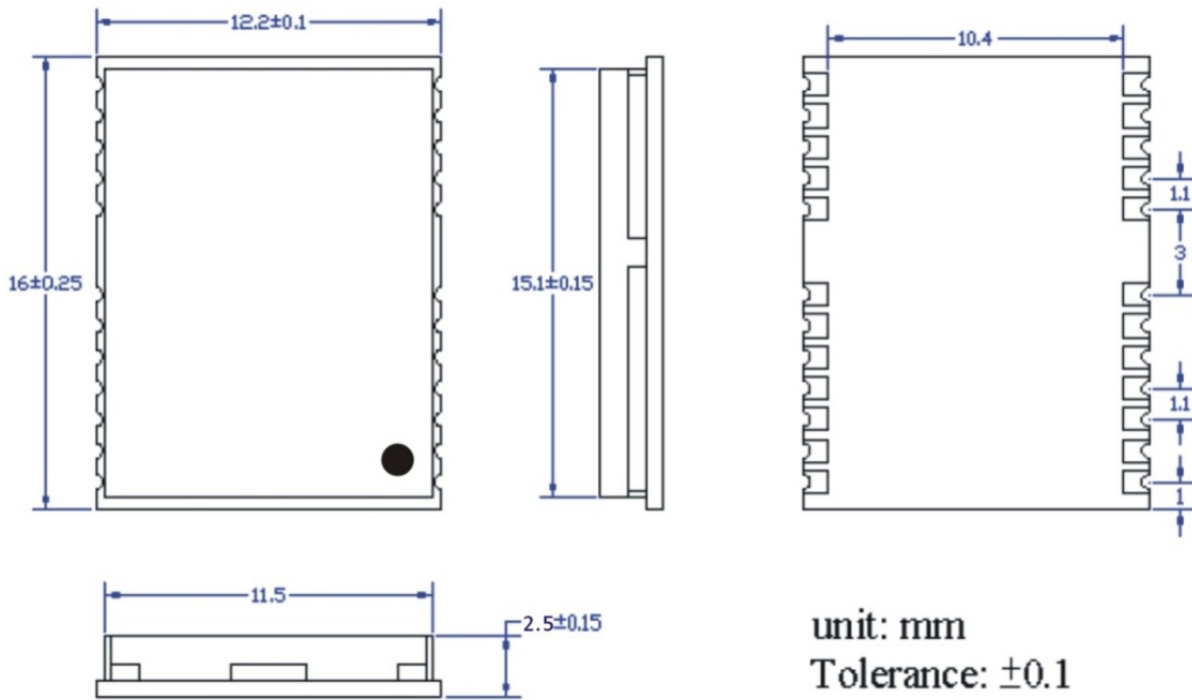

5. Recommended Footprint

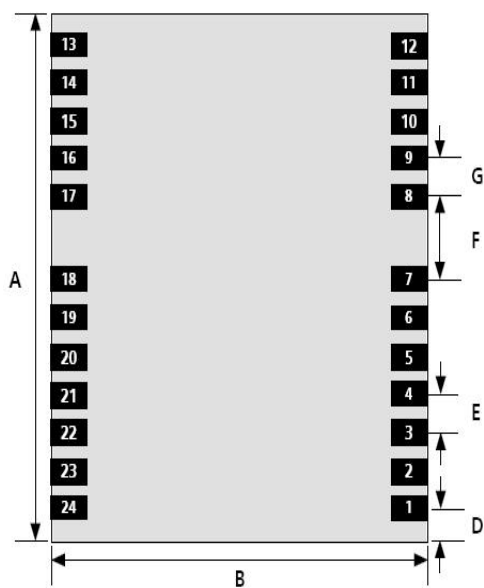

| Parameter | Specification | |
|-----------|---------------------|--------------------|
| A | $16.0 +0.6/-0.1$ mm | [628.8 +24/-4mil] |
| B | 12.2 ± 0.1 mm | [479.5 \pm 4mil] |
| C | 2.4 ± 0.2 mm | [94.3 \pm 8mil] |
| D | $1.0 +0.3/-0.1$ mm | [39.3 +18/-4mil] |
| E | 1.1 ± 0.1 mm | [43.2 \pm 4mil] |
| F | 3.0 ± 0.1 mm | [117.9 \pm 4mil] |
| G | 1.1 ± 0.1 mm | [43.2 \pm 4mil] |
| Weight | 1.6 g | |

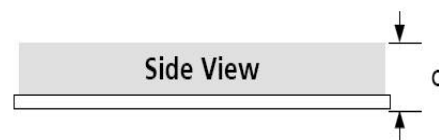

6. Application Circuit

6.1 With Active Antenna

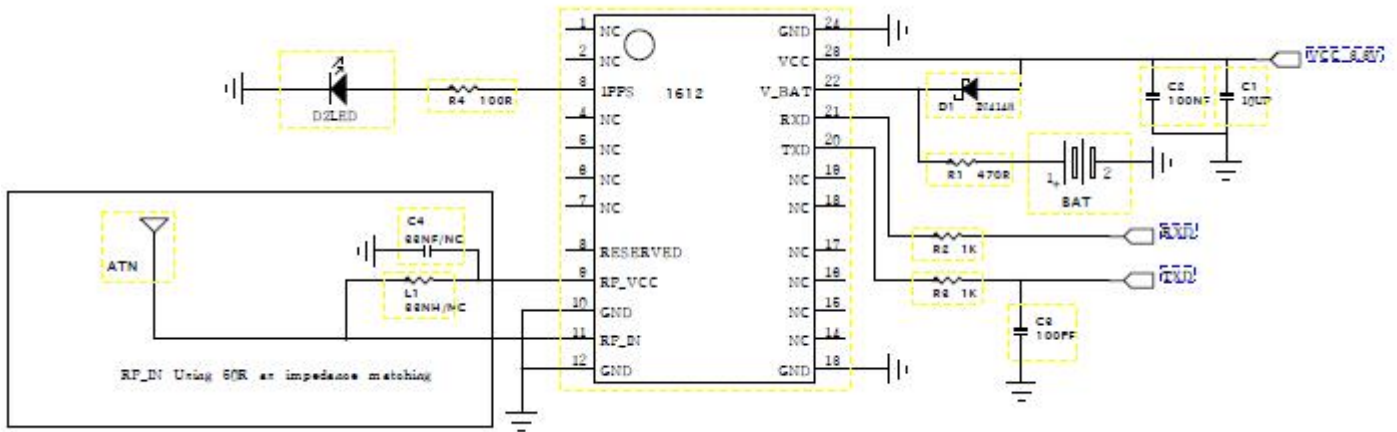

6.2 With Passive Antenna ,LNA & SAW Filter

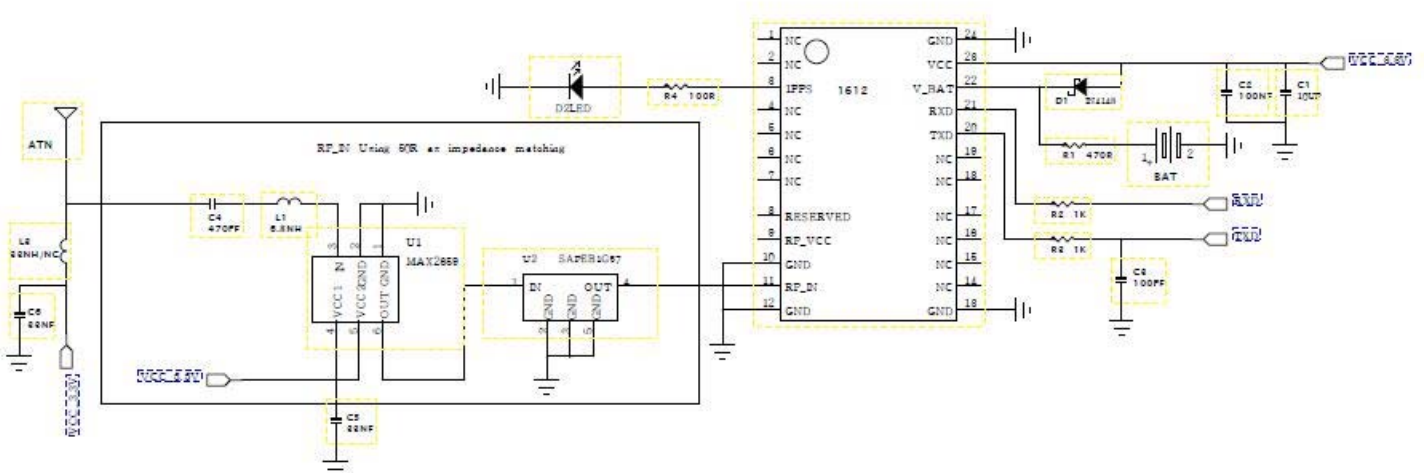

7. Reflow Profile

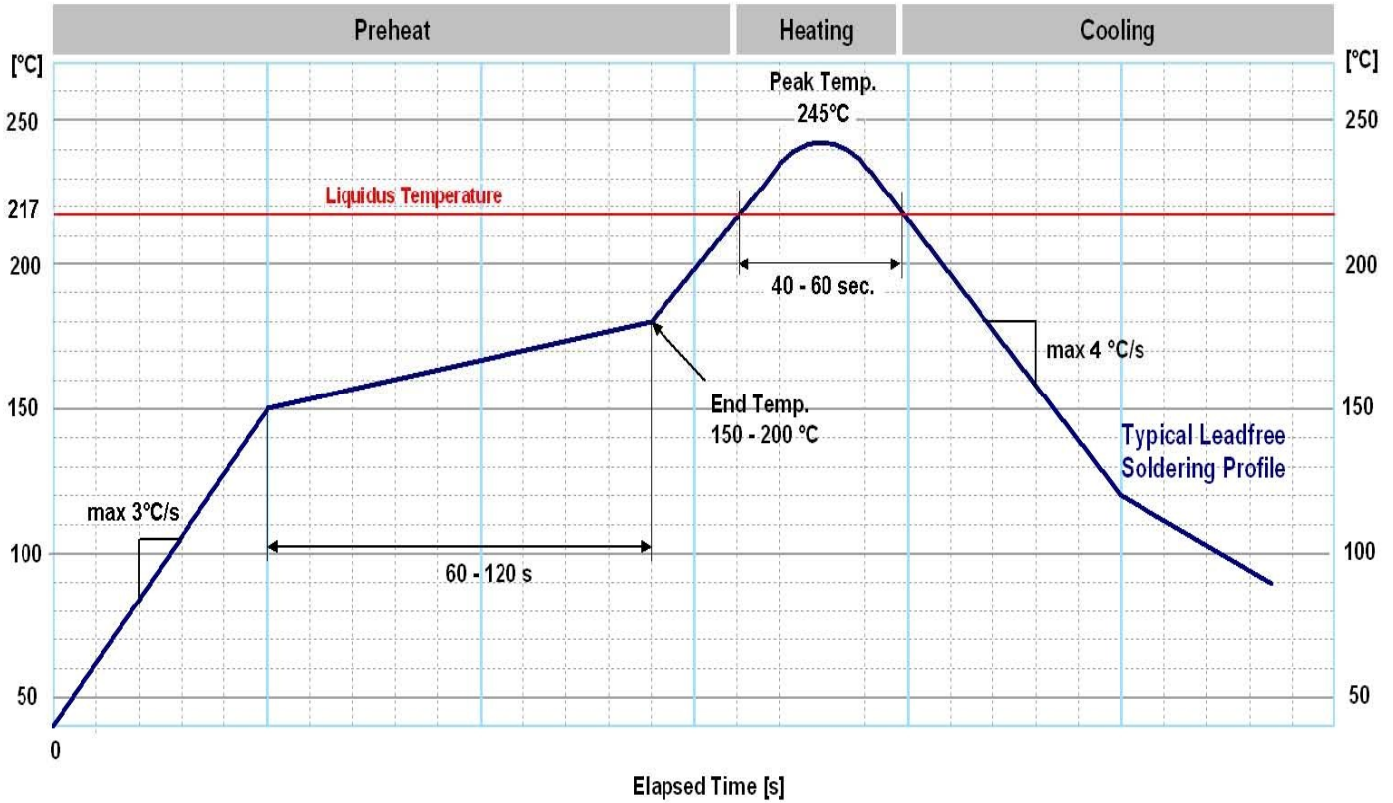

8. Tape & Reel (unit : mm)

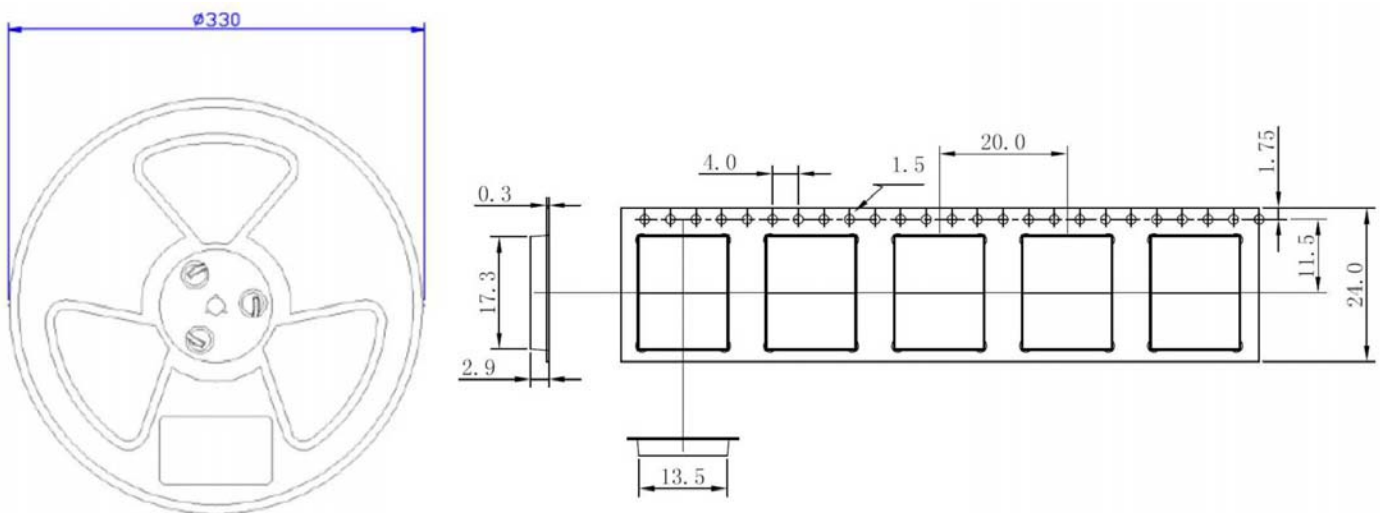

9. Software Interface

NMEA output message

Table 9.1 NMEA output message

| NMEA | Description |
|------|--|
| GGA | Global positioning system fixed data |
| GLL | Geographic position - latitude/longitude |
| GSA | GNSS DOP and active satellites |
| GSV | GNSS satellites in view |
| RMC | Recommended minimum specific GNSS data |
| VTG | Course over ground and ground speed |

GGA--- Global Positioning System Fixed Data

Table 9.2 contains the values for the following example:

\$GPGGA,060406.000,2503.7148,N,12138.7451,E,2,17,0.71,116.7,M,15.3,M,0000,0000*6D

Table 9.2 GGA Data Format

| Name | Example | Units | Description |
|------------------------|------------|--------|-----------------------------------|
| Message ID | \$GPGGA | | GGA protocol header |
| UTC Time | 060406.000 | | hhmmss.sss |
| Latitude | 2503.7148 | | ddmm.mmmm |
| N/S indicator | N | | N=north or S=south |
| Longitude | 12138.7451 | | dddmm.mmmm |
| E/W Indicator | E | | E=east or W=west |
| Position Fix Indicator | 2 | | See Table 9.3 |
| Satellites Used | 17 | | Range 0 to 33 |
| HDOP | 0.71 | | Horizontal Dilution of Precision |
| MSL Altitude | 116.7 | mters | |
| Units | M | mters | |
| Geoid Separation | 15.3 | mters | |
| Units | M | mters | |
| Age of Diff. Corr. | 0000 | second | Null fields when DGPS is not used |
| Diff. Ref. Station ID | 0000 | | |
| Checksum | *6D | | |
| <CR> <LF> | | | End of message termination |

Table 9.3 Position Fix Indicators

| Value | Description |
|-------|---------------------------------------|
| 0 | Fix not available or invalid |
| 1 | GPS SPS Mode, fix valid |
| 2 | Differential GPS, SPS Mode, fix valid |
| 3-5 | Not supported |
| 6 | Dead Reckoning Mode, fix valid |

GLL--- Geographic Position – Latitude/Longitude

Table 9.4 contains the values for the following example:

\$GNGLL,2503.7148,N,12138.7451,E,060406.000,A,D*46

Table 9.4 GLL Data Format

| Name | Example | Units | Description |
|---------------|------------|-------|--|
| Message ID | \$GNGLL | | GLL protocol header (GPGLL or GNGLL; GP indicates the device receives GPS satellites signal only and GN indicates the position is calculated with BEIDOU satellite signal) |
| Latitude | 2503.7148 | | ddmm.mmmm |
| N/S indicator | N | | N=north or S=south |
| Longitude | 12138.7451 | | dddmm.mmmm |
| E/W indicator | E | | E=east or W=west |
| UTC Time | 060406.000 | | hhmmss.sss |
| Status | A | | A=data valid or V=data not valid |
| Mode | D | | A=autonomous, D=DGPS, E=DR, N=Data not valid, R=Coarse Position, S=Simulator |
| Checksum | *46 | | |
| <CR> <LF> | | | End of message termination |

GSA---GNSS DOP and Active Satellites

Table 9.5 contains the values for the following example:

\$GNGSA,A,3,22,21,18,12,24,25,14,15,193,,,,,1.18,0.71,0.95*2C

\$GNGSA,A,3,205,207,210,202,201,203,209,208,,,,,1.18,0.71,0.95*1C

Table 9.5 GSA Data Format

| Name | Example | Units | Description |
|----------------------|---------|-------|---|
| Message ID | \$GNGSA | | GSA protocol header (GNGSA or GPGSA; GP indicates the device receives GPS satellites signal only and GN indicates the position is calculated with BEIDOU satellite signal). First row of GSA message contains GPS & QZSS satellites and second row of GSA message contains BEIDOU satellites. |
| Mode 1 | A | | See Table 9.6 |
| Mode 2 | 3 | | See Table 9.7 |
| ID of satellite used | 22 | | Sv on Channel 1 |
| ID of satellite used | 21 | | Sv on Channel 2 |
| | | | |
| ID of satellite used | | | Sv on Channel 12 |
| PDOP | 1.18 | | Position Dilution of Precision |
| HDOP | 0.71 | | Horizontal Dilution of Precision |
| VDOP | 0.95 | | Vertical Dilution of Precision |
| Checksum | *2C | | |
| <CR> <LF> | | | End of message termination |

Table 9.6 Mode 1

| Value | Description |
|-------|---|
| M | Manual- forced to operate in 2D or 3D mode |
| A | Automatic-allowed to automatically switch 2D/3D |

Table 9.7 Mode 2

| Value | Description |
|-------|-------------------|
| 1 | Fix not available |
| 2 | 2D |
| 3 | 3D |

GSV---GNSS Satellites in View

Table 9.8 contains the values for the following example:

\$GPGSV,6,1,21,18,78,169,36,209,72,273,36,22,63,309,38,207,63,328,38*7B

\$GPGSV,6,2,21,203,58,205,39,25,56,138,39,201,55,141,34,206,50,168,*45

\$GPGSV,6,3,21,210,49,282,34,12,48,076,39,204,39,118,,14,38,322,37*77

\$GPGSV,6,4,21,193,37,180,34,202,36,246,29,24,23,041,34,31,21,244,*71

\$GPGSV,6,5,21,21,17,198,33,205,16,258,28,15,12,092,33,208,09,169,30*7B

\$GPGSV,6,6,21,51,,,*7E

Table 9.8 GSV Data Format

| Name | Example | Units | Description |
|---------------------------|---------|---------|---|
| Message ID | \$GPGSV | | GSV protocol header |
| Total number of messages1 | 6 | | Range 1 to 6 |
| Message number1 | 1 | | Range 1 to 6 |
| Satellites in view | 21 | | |
| Satellite ID | 18 | | Channel 1 (Range 01 to 237), GPS Satellites ID : 01~32,SBAS Satellites ID : 33~64, QZSS Satellites ID:193~196, &BEIDOU Satellites ID : 201~214 |
| Elevation | 78 | degrees | Channel 1 (Range 00 to 90) |
| Azimuth | 169 | degrees | Channel 1 (Range 000 to 359) |
| SNR (C/No) | 36 | dB-Hz | Channel 1 (Range 00 to 99, null when not tracking) |
| | | | |
| Satellite ID | 207 | | Channel 4 (Range 01 to 237) , GPS Satellites ID : 01~32,SBAS Satellites ID : 33~64, QZSS Satellites ID:193~196, &BEIDOU Satellites ID : 201~214 |
| Elevation | 63 | degrees | Channel 4 (Range 00 to 90) |
| Azimuth | 328 | degrees | Channel 4 (Range 000 to 359) |
| SNR (C/No) | 38 | dB-Hz | Channel 4 (Range 00 to 99, null when not tracking) |
| Checksum | *7B | | |
| <CR> <LF> | | | End of message termination |

Depending on the number of satellites tracked multiple messages of GSV data may be required.

RMC---Recommended Minimum Specific GNSS Data

Table 9.9 contains the values for the following example:

\$GNRMC,060406.000,A,2503.7148,N,12138.7451,E,0.01,0.00,180313,,D*78

Table 9.9 RMC Data Format

| Name | Example | Units | Description |
|--------------------|------------|---------|--|
| Message ID | \$GNRMC | | RMC protocol header (GNRMC or GPRMC; GP indicates the device receives GPS satellites signal only and GN indicates the position is calculated with BEIDOU satellite signal) |
| UTC Time | 060406.000 | | hhmmss.sss |
| Status | A | | A=data valid or V=data not valid |
| Latitude | 2503.7148 | | ddmm.mmmm |
| N/S Indicator | N | | N=north or S=south |
| Longitude | 12138.7451 | | dddmm.mmmm |
| E/W Indicator | E | | E=east or W=west |
| Speed over ground | 0.01 | knots | True |
| Course over ground | 0.00 | degrees | |
| Date | 180313 | | ddmmyy |
| Magnetic variation | | degrees | |
| Variation sense | | | E=east or W=west (Not shown) |
| Mode | D | | A=autonomous, D=DGPS, E=DR, N=Data not valid, R=Coarse Position, S=Simulator |
| Checksum | *78 | | |
| <CR> <LF> | | | End of message termination |

VTG---Course Over Ground and Ground Speed

Table 9.10 contains the values for the following example:

\$GPVTG,0.00,T,,M,0.01,N,0.02,K,D*3B

Table 9.10 VTG Data Format

| Name | Example | Units | Description |
|--------------------|---------|---------|--|
| Message ID | \$GPVTG | | VTG protocol header |
| Course over ground | 0.00 | degrees | Measured heading |
| Reference | T | | True |
| Course over ground | | degrees | Measured heading |
| Reference | M | | Magnetic |
| Speed over ground | 0.01 | knots | Measured speed |
| Units | N | | Knots |
| Speed over ground | 0.02 | km/hr | Measured speed |
| Units | K | | Kilometer per hour |
| Mode | D | | A=autonomous, D=DGPS, E=DR, N=Data not valid, R=Coarse Position, S=Simulator |
| Checksum | *3B | | |
| <CR> <LF> | | | End of message termination |