



RAYSTAR

RAYSTAR Optronics, Inc.
曜凌光電股份有限公司



曜凌光電股份有限公司 Raystar Optronics, Inc.

42881台中市大雅區科雅路25號5樓
5F, No. 25, Keya Road, Daya Dist., Taichung City 42881, Taiwan
T : +886-4-2565-0761 | F : +886-4-2565-0760
sales@raystar-optronics.com | www.raystar-optronics.com

RFJ240H-ALW-DNN

SPECIFICATION

CUSTOMER:

APPROVED BY	
PCB VERSION	
DATE	

FOR CUSTOMER USE ONLY

SALES BY	APPROVED BY	CHECKED BY	PREPARED BY

Release DATE:

TFT Display Inspection Specification: <https://www.raystar-optronics.com/download/products.htm>
Precaution in use of TFT module: <https://www.raystar-optronics.com/download/declaration.htm>

Revision History

VERSION	DATE	REVISED PAGE NO.	Note
0	2017/04/27		First issue
A	2017/05/19		Modify LED Life Time
B	2017/06/07		Modify LED Life Time
C	2017/08/22		Modify Life Time
D	2019/10/31		Add Uniformity Modify Contour Drawing.
E	2020/04/13		Correct Interface (IM0)
F	2020/09/28		Add IC and Interface Modify Backlight.

Contents

1. Module Classification Information
2. Summary
3. General Specification
4. Interface
5. Contour Drawing
6. Block Diagram
7. Absolute Maximum Ratings
8. Electrical Characteristics
9. DC Characteristics
10. AC Characteristics
11. Optical Characteristics
12. Reliability
13. Other

RAYSTAR OPTRONICS

2.Summary

TFT 2.4" is a TN transmissive type color active matrix TFT liquid crystal display that uses amorphous silicon TFT as switching devices. This module is composed of a TFT_LCD module, it is usually designed for industrial application and this module follows RoHS,

RAYSTAR OPTRONICS

3. General Specifications

- Size: 2.4"
- Dot Matrix: 240 x RGB x 320(TFT) dots
- Module dimension: 42.72(W) x 60.26(H) x 2.25(D) mm
- Active area: 36.72 x 48.96 mm
- Dot pitch: 0.051 x 0.153 mm
- LCD type: TFT, Normally White, Transmissive
- View Direction: 6 o'clock
- Gray Scale Inversion Direction: 12 o'clock
- Aspect Ratio: Portrait
- Control IC: ILI9341V or Equivalent
- Interface: 8-bit/16-bit CPU (build in controller)
- Backlight Type: LED, Normally White
- With /Without TP: Without TP
- Surface: Glare

*Color tone slight changed by temperature and driving voltage.

4.Interface

4.1. LCM PIN Definition

NO	Symbol	Function	I/O
1	GND	Ground	P
2-5	NC	No connect	-
6	LCD_ID	No connect	-
7	VCC	power supply(TYP:2.8V).	P
8	IOVCC	power supply(TYP:1.8V/2.8V).	P
9	FMARK	Synchronies MCU to frame rate	O
10	CS	Chip select signal.	I
11	RS	register select	I
12	WR	Write data when WRX is Low.	I
13	RD	Read strobe signal. Read out data when RDX is Low.	I
14-29	DB0- DB15	Data bus	I/O
30	RESET	System reset pin.	I
31	IM0	Data interface select IM0= IOVCC 16Bit DB0-DB15 IM0= GND 8Bit DB0-DB7	I
32	NC	No connect	-
33	GND	Ground	P
34-37	LEDK1-K4	Cathode of LED backlight.	P
38	LEDA	Anode of LED backlight.	P
39	GND	Ground	P

6. Block Diagram

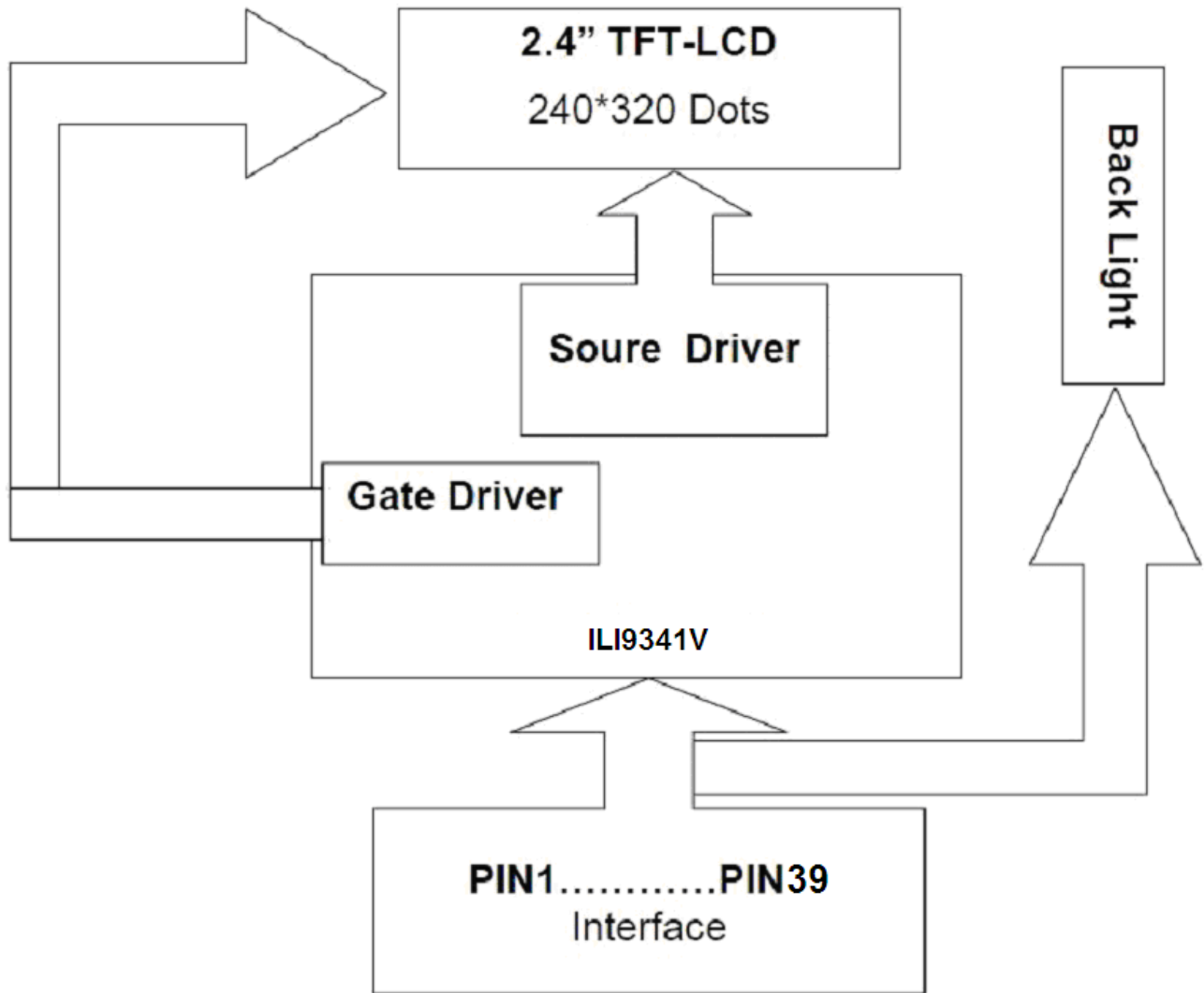

RAYSTAR

7. Absolute Maximum Ratings

Item	Symbol	Min	Typ	Max	Unit
Operating Temperature	TOP	-20	—	+70	°C
Storage Temperature	TST	-30	—	+80	°C

Note: Device is subject to be damaged permanently if stresses beyond those absolute maximum ratings listed above

Temp. $\leq 60^{\circ}\text{C}$, 90% RH MAX. Temp. $> 60^{\circ}\text{C}$, Absolute humidity shall be less than 90% RH at 60°C

RAYSTAR OPTRONICS

8. Electrical Characteristics

8.1. Operating conditions:

Item	Symbol	Condition	Min	Typ	Max	Unit
Supply Voltage For Analog	VCC	—	2.4		3.3	V
Supply Voltage For Logic	VCCIO		1.65		3.3	V
Supply Current For LCM	ICC	—	—	5	7.5	mA

8.2. LED driving conditions

Parameter	Symbol	Min.	Typ.	Max.	Unit	Remark
LED current		-	80	-	mA	
Power Consumption		-	256	-	mW	
LED voltage	VBL+	2.8	3.1	3.3	V	Note 1
LED Life Time		-	50,000	-	Hr	Note 2,3,4

Note 1 : There are 1 Groups LED

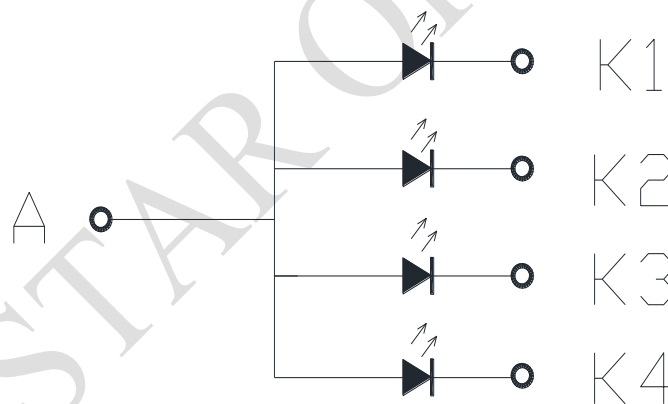

Note 2 : $T_a = 25\text{ }^\circ\text{C}$

Note 3 : Brightness to be decreased to 50% of the initial value

Note 4 : The single LED lamp case

9.DC Characteristics

Parameter	Symbol	Rating			Unit	Condition
		Min	Typ	Max		
Low level input voltage	V_{IL}	0	-	0.3VCC	V	
High level input voltage	V_{IH}	0.7VCC	-	VCC	V	

RAYSTAR OPTRONICS

10.AC Characteristics

10.1. 8080 Series MCU Parallel Interface Characteristics: 18/16/9/8-bit Bus

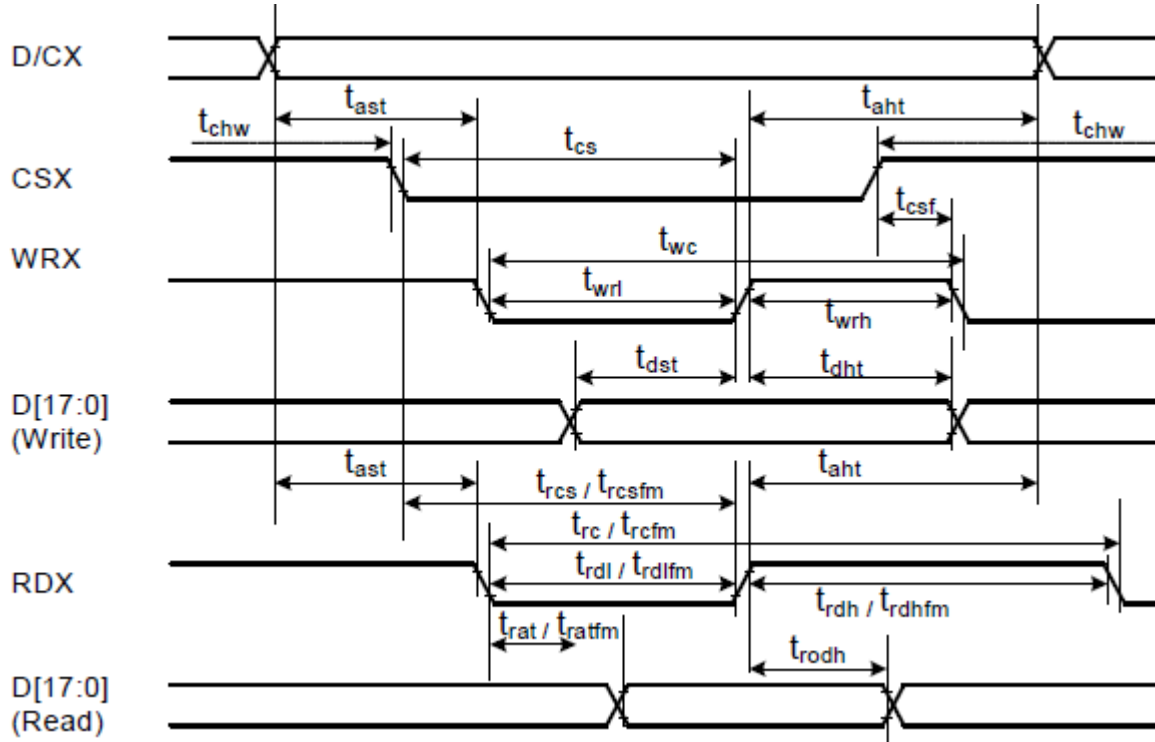

Signal	Symbol	Parameter	min	max	Unit	Description
DCX	tast	Address setup time	0	-	ns	
	taht	Address hold time (Write/Read)	0	-	ns	
CSX	tchw	CSX "H" pulse width	0	-	ns	
	tcs	Chip Select setup time (Write)	15	-	ns	
	trcs	Chip Select setup time (Read ID)	45	-	ns	
	trcsfm	Chip Select setup time (Read FM)	355	-	ns	
WRX	tcsf	Chip Select Wait time (Write/Read)	10	-	ns	
	twc	Write cycle	66	-	ns	
	twrh	Write Control pulse H duration	15	-	ns	
RDX (FM)	twrl	Write Control pulse L duration	15	-	ns	
	trcfm	Read Cycle (FM)	450	-	ns	
	trdhfm	Read Control H duration (FM)	90	-	ns	
RDX (ID)	trdlfm	Read Control L duration (FM)	355	-	ns	
	trc	Read cycle (ID)	160	-	ns	
	trdh	Read Control pulse H duration	90	-	ns	
D[17:0], D[15:0], D[8:0], D[7:0]	trdl	Read Control pulse L duration	45	-	ns	
	tdst	Write data setup time	10	-	ns	
	tdht	Write data hold time	10	-	ns	
	trat	Read access time	-	40	ns	For maximum CL=30pF For minimum CL=8pF
tratfm	Read access time	-	340	ns		
	trodh	Read output disable time	20	80	ns	

Note: $T_a = -30$ to 70 °C, $V_{DDI}=1.65V$ to $3.3V$, $V_{CI}=2.5V$ to $3.3V$, $V_{SS}=0V$

CSX timings :

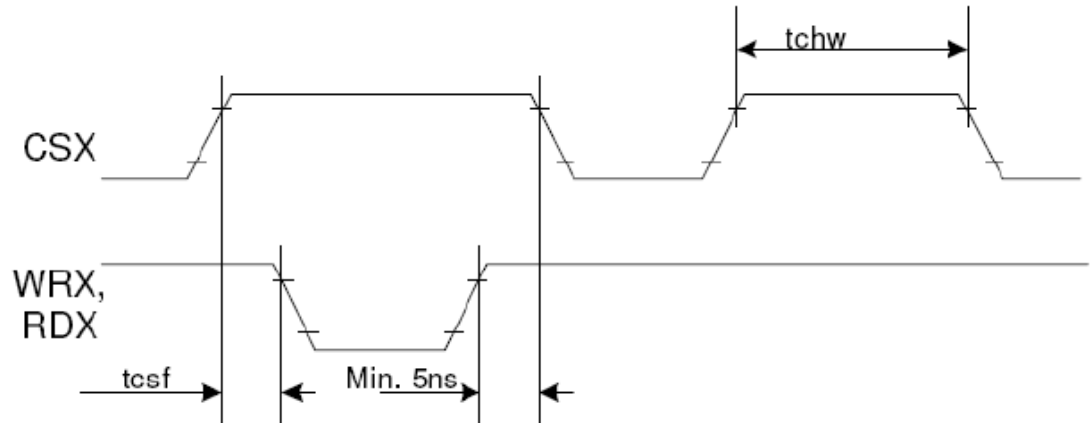

Note: Logic high and low levels are specified as 30% and 70% of VDDI for Input signals.

Write to read or read to write timings:

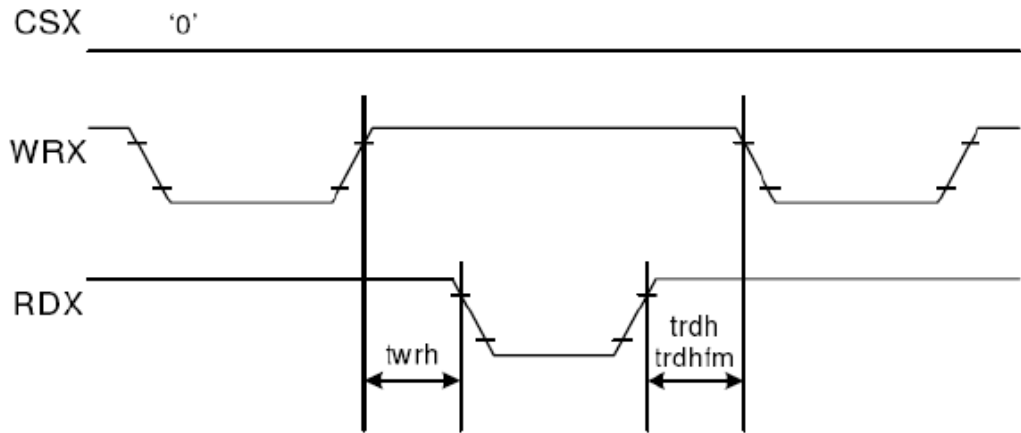

Note: Logic high and low levels are specified as 30% and 70% of VDDI for Input signals.

RAYSTAR

10.2. Interface Pixel Format

3Ah	PIXSET (Pixel Format Set)																																																																																				
	D/CX	RDX	WRX	D17-8	D7	D6	D5	D4	D3	D2	D1	D0	HEX																																																																								
Command	0	1	↑	XX	0	0	1	1	1	0	1	0	3Ah																																																																								
Parameter	1	1	↑	XX	0	DPI [2:0]			0	DBI [2:0]			66																																																																								
Description	<p>This command sets the pixel format for the RGB image data used by the interface. DPI [2:0] is the pixel format select of RGB interface and DBI [2:0] is the pixel format of MCU interface. If a particular interface, either RGB interface or MCU interface, is not used then the corresponding bits in the parameter are ignored. The pixel format is shown in the table below.</p> <table border="1" style="margin-left: auto; margin-right: auto;"> <thead> <tr> <th colspan="3">DPI [2:0]</th> <th>RGB Interface Format</th> <th colspan="3">DBI [2:0]</th> <th>MCU Interface Format</th> </tr> </thead> <tbody> <tr><td>0</td><td>0</td><td>0</td><td>Reserved</td><td>0</td><td>0</td><td>0</td><td>Reserved</td></tr> <tr><td>0</td><td>0</td><td>1</td><td>Reserved</td><td>0</td><td>0</td><td>1</td><td>Reserved</td></tr> <tr><td>0</td><td>1</td><td>0</td><td>Reserved</td><td>0</td><td>1</td><td>0</td><td>Reserved</td></tr> <tr><td>0</td><td>1</td><td>1</td><td>Reserved</td><td>0</td><td>1</td><td>1</td><td>Reserved</td></tr> <tr><td>1</td><td>0</td><td>0</td><td>Reserved</td><td>1</td><td>0</td><td>0</td><td>Reserved</td></tr> <tr><td>1</td><td>0</td><td>1</td><td>16 bits / pixel</td><td>1</td><td>0</td><td>1</td><td>16 bits / pixel</td></tr> <tr><td>1</td><td>1</td><td>0</td><td>18 bits / pixel</td><td>1</td><td>1</td><td>0</td><td>18 bits / pixel</td></tr> <tr><td>1</td><td>1</td><td>1</td><td>Reserved</td><td>1</td><td>1</td><td>1</td><td>Reserved</td></tr> </tbody> </table> <p>If using RGB Interface must selection serial interface. X = Don't care</p>													DPI [2:0]			RGB Interface Format	DBI [2:0]			MCU Interface Format	0	0	0	Reserved	0	0	0	Reserved	0	0	1	Reserved	0	0	1	Reserved	0	1	0	Reserved	0	1	0	Reserved	0	1	1	Reserved	0	1	1	Reserved	1	0	0	Reserved	1	0	0	Reserved	1	0	1	16 bits / pixel	1	0	1	16 bits / pixel	1	1	0	18 bits / pixel	1	1	0	18 bits / pixel	1	1	1	Reserved	1	1	1	Reserved
	DPI [2:0]			RGB Interface Format	DBI [2:0]			MCU Interface Format																																																																													
	0	0	0	Reserved	0	0	0	Reserved																																																																													
	0	0	1	Reserved	0	0	1	Reserved																																																																													
	0	1	0	Reserved	0	1	0	Reserved																																																																													
	0	1	1	Reserved	0	1	1	Reserved																																																																													
	1	0	0	Reserved	1	0	0	Reserved																																																																													
	1	0	1	16 bits / pixel	1	0	1	16 bits / pixel																																																																													
	1	1	0	18 bits / pixel	1	1	0	18 bits / pixel																																																																													
	1	1	1	Reserved	1	1	1	Reserved																																																																													

10.3. 8-bit Parallel MCU Interface

The 8080- I system 8-bit parallel bus interface of ILI9341V can be used by setting external pin as IM [3:0] to "0000". The following shown figure is the example of interface with 8080- I MCU system interface.

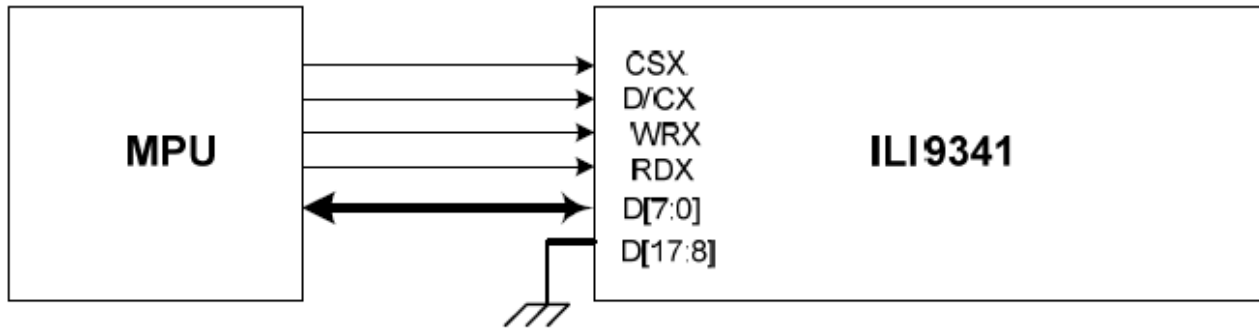

- Different display data formats are available for two color depths supported by listed below.
- 65K-Colors, RGB 5, 6, 5 -bits input data.
 - 262K-Colors, RGB 6, 6, 6 -bits input data.

65K color: 16-bit/pixel (RGB 5-6-5 bits input)

One pixel (3 sub-pixels) display data is sent by 2 byte transfers when DBI [2:0] bits of 3Ah register are set to "101".

Count	0	1	2	3	4	...	477	478	479	480
D/CX	0	1	1	1	1	...	1	1	1	1
D7	C7	0R4	0G2	1R4	1G2	...	238R4	238G2	239R4	239G2
D6	C6	0R3	0G1	1R3	1G1	...	238R3	238G1	239R3	239G1
D5	C5	0R2	0G0	1R2	1G0	...	238R2	238G0	239R2	239G0
D4	C4	0R1	0B4	1R1	1B4	...	238R1	238B4	239R1	239B4
D3	C3	0R0	0B3	1R0	1B3	...	238R0	238B3	239R0	239B3
D2	C2	0G5	0B2	1G5	1B2	...	238G5	238B2	239G5	239B2
D1	C1	0G4	0B1	1G4	1B1	...	238G4	238B1	239G4	239B1
D0	C0	0G3	0B0	1G3	1B0	...	238G3	238B0	239G3	239B0

262K color: 18-bit/pixel (RGB 6-6-6 bits input)

One pixel (3 sub-pixels) display data is sent by 3 bytes transfer when DBI [2:0] bits of 3Ah register are set to "110".

Count	0	1	2	3	...	718	719	720
D/CX	0	1	1	1	...	1	1	1
D7	C7	0R5	0G5	0B5	...	239R5	239G5	239B5
D6	C6	0R4	0G4	0B4	...	239R4	239G4	239B4
D5	C5	0R3	0G3	0B3	...	239R3	239G3	239B3
D4	C4	0R2	0G2	0B2	...	239R2	239G2	239B2
D3	C3	0R1	0G1	0B1	...	239R1	239G1	239B1
D2	C2	0R0	0G0	0B0	...	239R0	239G0	239B0
D1	C1				...			
D0	C0				...			

16-bit Parallel MCU Interface

The 8080- I system 16-bit parallel bus interface of ILI9341V can be selected by setting hardware pin IM[3:0] to "0001". The following shown figure is the example of interface with 8080- I MCU system interface.

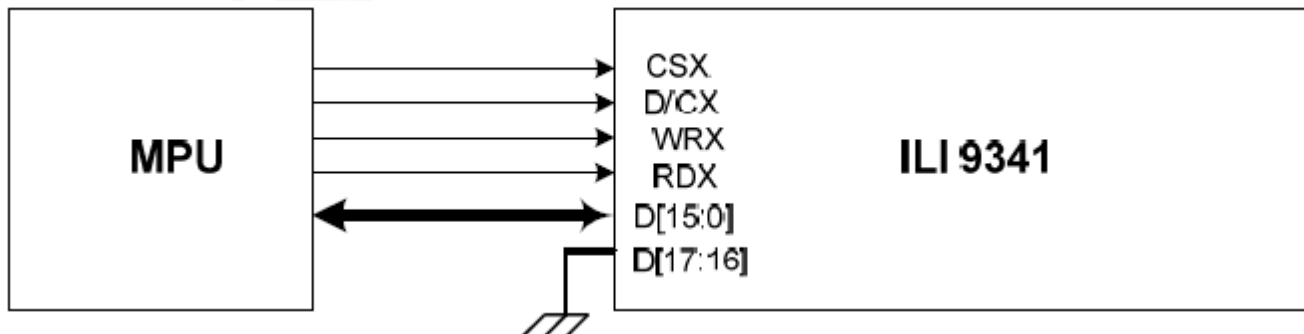

Different display data format is available for two colors depth supported by listed below.

- 65K-Colors, RGB 5, 6, 5 -bits input data.
- 262K-Colors, RGB 6, 6, 6 -bits input data.

65K color: 16-bit/pixel (RGB 5-6-5 bits input)

One pixel (3 sub-pixels) display data is sent by 1 transfer when DBI [2:0] bits of 3Ah register are set to "101".

Count	0	1	2	3	...	238	239	240
D/CX	0	1	1	1	...	1	1	1
D15		0R4	1R4	2R4	...	237R4	238R4	239R4
D14		0R3	1R3	2R3	...	237R3	238R3	239R3
D13		0R2	1R2	2R2	...	237R2	238R2	239R2
D12		0R1	1R1	2R1	...	237R1	238R1	239R1
D11		0R0	1R0	2R0	...	237R0	238R0	239R0
D10		0G5	1G5	2G5	...	237G5	238G5	239G5
D9		0G4	1G4	2G4	...	237G4	238G4	239G4
D8		0G3	1G3	2G3	...	237G3	238G3	239G3
D7	C7	0G2	1G2	2G2	...	237G2	238G2	239G2
D6	C6	0G1	1G1	2G1	...	237G1	238G1	239G1
D5	C5	0G0	1G0	2G0	...	237G0	238G0	239G0
D4	C4	0B4	1B4	2B4	...	237B4	238B4	239B4
D3	C3	0B3	1B3	2B3	...	237B3	238B3	239B3
D2	C2	0B2	1B2	2B2	...	237B2	238B2	239B2
D1	C1	0B1	1B1	2B1	...	237B1	238B1	239B1
D0	C0	0B0	1B0	2B0	...	237B0	238B0	239B0

262K color: 18-bit/pixel (RGB 6-6-6 bits input)

One pixel (3 sub-pixels) display data is sent by 2 transfers when DBI [2:0] bits of 3Ah register are set to "110".

MDT[1:0]="00"

Count	0	1	2	3	...	358	359	360
D/CX	0	1	1	1	...	1	1	1
D15		0R5	0B5	1G5	...	238R5	238B5	239G5
D14		0R4	0B4	1G4	...	238R4	238B4	239G4
D13		0R3	0B3	1G3	...	238R3	238B3	239G3
D12		0R2	0B2	1G2	...	238R2	238B2	239G2
D11		0R1	0B1	1G1	...	238R1	238B1	239G1
D10		0R0	0B0	1G0	...	238R0	238B0	239G0
D9					...			
D8					...			
D7	C7	0G5	1R5	1B5	...	238G5	239R5	239B5
D6	C6	0G4	1R4	1B4	...	238G4	239R4	239B4
D5	C5	0G3	1R3	1B3	...	238G3	239R3	239B3
D4	C4	0G2	1R2	1B2	...	238G2	239R2	239B2
D3	C3	0G1	1R1	1B1	...	238G1	239R1	239B1
D2	C2	0G0	1R0	1B0	...	238G0	239R0	239B0
D1	C1				...			
D0	C0				...			

MDT[1:0]="01"

Count	0	1	2	3	...	357	358	479	480	
D/CX	0	1	1	1	...		1	1	1	
D15		0R5	0B5	1R5	1B5	...	238R5	238B5	239R5	239B5
D14		0R4	0B4	1R4	1B4	...	238R4	238B4	239R4	239B4
D13		0R3	0B3	1R3	1B3	...	238R3	238B3	239R3	239B3
D12		0R2	0B2	1R2	1B2	...	238R2	238B2	239R2	239B2
D11		0R1	0B1	1R1	1B1	...	238R1	238B1	239R1	239B1
D10		0R0	0B0	1R0	1B0	...	238R0	238B0	239R0	239B0
D9					...					
D8					...					
D7	C7	0G5		1G5	...	238G5		239G5		
D6	C6	0G4		1G4	...	238G4		239G4		
D5	C5	0G3		1G3	...	238G3		239G3		
D4	C4	0G2		1G2	...	238G2		239G2		
D3	C3	0G1		1G1	...	238G1		239G1		
D2	C2	0G0		1G0	...	238G0		239G0		
D1	C1				...					
D0	C0				...					

MDT[1:0]="10"

Count	0	1	2	3	...	357	358	479	480	
D/CX	0	1	1	1	...		1	1	1	
D15		0R5	0B1	1R5	1B1	...	238R5	238B1	239R5	239B1
D14		0R4	0B0	1R4	1B0	...	238R4	238B0	239R4	239B0
D13		0R3		1R3		...	238R3		239R3	
D12		0R2		1R2		...	238R2		239R2	
D11		0R1		1R1		...	238R1		239R1	
D10		0R0		1R0		...	238R0		239R0	
D9		0G5		1G5		...	238G5		239G5	
D8		0G4		1G4		...	238G4		239G4	
D7	C7	0G3		1G3		...	238G3		239G3	
D6	C6	0G2		1G2		...	238G2		239G2	
D5	C5	0G1		1G1		...	238G1		239G1	
D4	C4	0G0		1G0		...	238G0		239G0	
D3	C3	0B5		1B5		...	238B5		239B5	
D2	C2	0B4		1B4		...	238B4		239B4	
D1	C1	0B3		1B3		...	238B3		239B3	
D0	C0	0B2		1B2		...	238B2		239B2	

MDT[1:0]="11"

Count	0	1	2	3	...	357	358	479	480
D/CX	0	1	1	1	...		1	1	1
D15			0R3		1R3	...	238R3		239R3
D14			0R2		1R2	...	238R2		239R2
D13			0R1		1R1	...	238R1		239R1
D12			0R0		1R0	...	238R0		239R0
D11			0G5		1G5	...	238G5		239G5
D10			0G4		1G4	...	238G4		239G4
D9			0G3		1G3	...	238G3		239G3
D8			0G2		1G2	...	238G2		239G2
D7	C7		0G1		1G1	...	238G1		239G1
D6	C6		0G0		1G0	...	238G0		239G0
D5	C5		0B5		1B5	...	238B5		239B5
D4	C4		0B4		1B4	...	238B4		239B4
D3	C3		0B3		1B3	...	238B3		239B3
D2	C2		0B2		1B2	...	238B2		239B2
D1	C1	0R5	0B1	1R5	1B1	...	238R5	238B1	239R5
D0	C0	0R4	0B0	1R4	1B0	...	238R4	238B0	239R4

10.4. Reset Timing

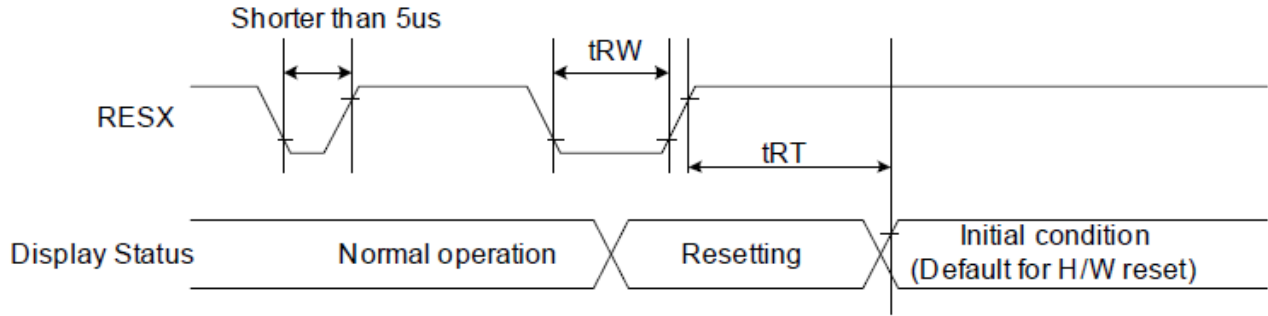

Signal	Symbol	Parameter	Min	Max	Unit
RESX	tRW	Reset pulse duration	10		us
	tRT	Reset cancel		5 (Note 1, 5) 120 (Note 1, 6, 7)	ms

VDDI=1.65 to 3.3V, VDD=2.4 to 3.3V, AGND=DGND=0V, Ta=-30 ~ 70 °C

Notes:

1. The reset cancel includes also required time for loading ID bytes, VCOM setting and other settings from NVM (or similar device) to registers. This loading is done every time when there is HW reset cancel time (tRT) within 5 ms after a rising edge of RESX.

2. Spike due to an electrostatic discharge on RESX line does not cause irregular system reset according to the table below:

RESX Pulse	Action
Shorter than 5us	Reset Rejected
Longer than 10us	Reset
Between 5us and 10us	Reset starts

3. During the Resetting period, the display will be blanked (The display is entering blanking sequence, which maximum time is 120 ms, when Reset Starts in Sleep Out –mode. The display remains the blank state in Sleep In –mode.) and then return to Default condition for Hardware Reset.

4. Spike Rejection also applies during a valid reset pulse as shown below:

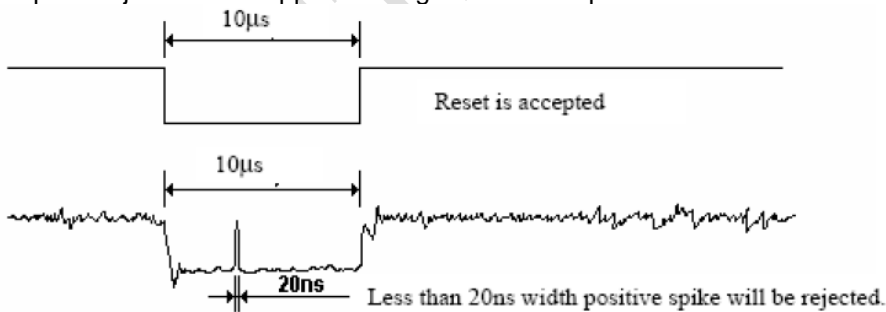

5. When Reset applied during Sleep In Mode.

6. When Reset applied during Sleep Out Mode.

7. It is necessary to wait 5msec after releasing RESX before sending commands. Also Sleep Out command cannot be sent for 120msec.

11. Optical Characteristics

Item	Symbol	Condition.	Min	Typ.	Max.	Unit	Remark	
Response time	Tr	$\theta=0^\circ$ 、 $\phi=0^\circ$	-	4	8	ms	Note 3,	
	Tf		-	12	24	ms		
Contrast ratio	CR	At optimized viewing angle	400	500	-	-	Note 4,	
Color Chromaticity	White	$\theta=0^\circ$ 、 $\phi=0^\circ$	Wx	0.26	0.31	0.36	Note 2,6,7	
	Wy		0.28	0.33	0.38			
Viewing angle (Gray Scale Inversion Direction)	Hor.	$CR \geq 10$	θ_R	35	45	-	Deg.	Note 1
			θ_L	35	45	-		
	Ver.		ϕ_T	35	45	-		
			ϕ_B	10	20	-		
Brightness	-	-	400	500	-	cd/m ²	Center of display	
Uniformity	(U)	-	75	-	-	%	Note 5	

Ta=25±2°C

Note 1: Definition of viewing angle range

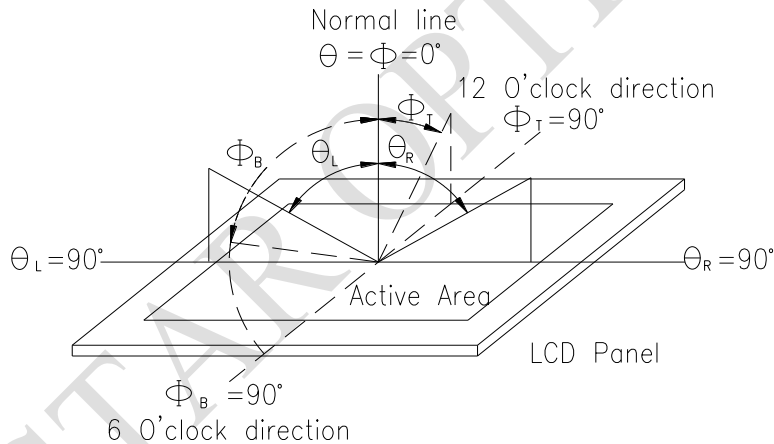

Fig. 11.1. Definition of viewing angle

Note 2: Test equipment setup:

After stabilizing and leaving the panel alone at a driven temperature for 10 minutes, the measurement should be executed. Measurement should be executed in a stable, windless, and dark room. Optical specifications are measured by Topcon BM-7 or BM-5 luminance meter 1.0° field of view at a distance of 50cm and normal direction.

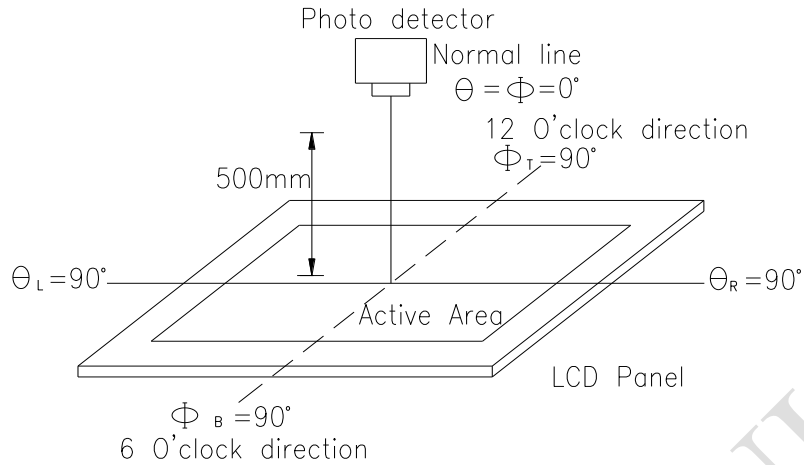
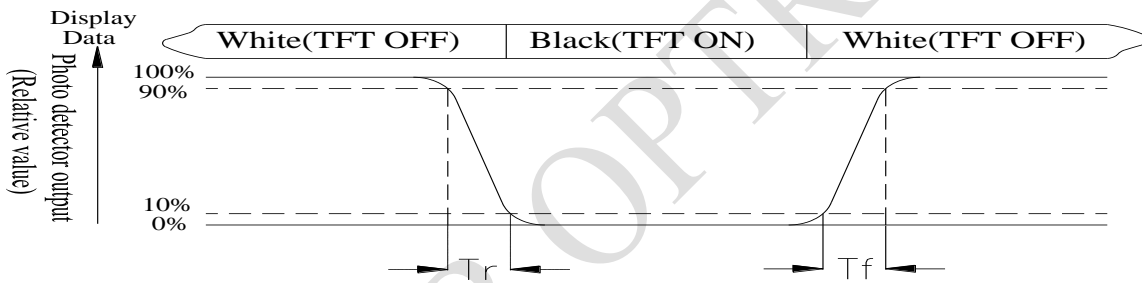

Fig. 11.2. Optical measurement system setup

Note 3: Definition of Response time:

The response time is defined as the LCD optical switching time interval between "White" state and "Black" state. Rise time, T_r , is the time between photo detector output intensity changed from 90% to 10%. And fall time, T_f , is the time between photo detector output intensity changed from 10% to 90%



Note 4: Definition of contrast ratio:

The contrast ratio is defined as the following expression.

$$\text{Contrast ratio (CR)} = \frac{\text{Luminance measured when LCD on the "White" state}}{\text{Luminance measured when LCD on the "Black" state}}$$

Note 5: Definition of Luminance Uniformity

Active area is divided into 9 measuring areas (reference the picture in below). Every measuring point is placed at the center of each measuring area.

Luminance Uniformity (U) = $L_{min}/L_{max} \times 100\%$

L = Active area length

W = Active area width

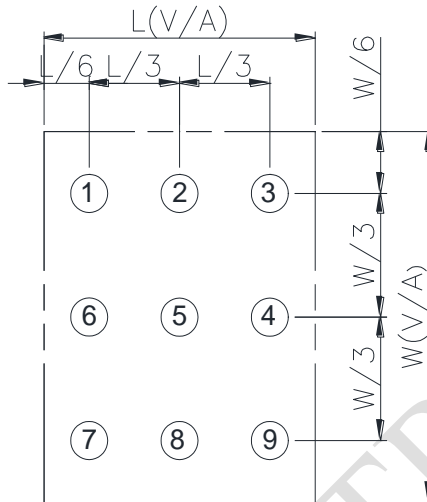

Fig Definition of uniformity

Note 6: Definition of color chromaticity (CIE 1931)

Color coordinates measured at the center point of LCD

Note 7: Measured at the center area of the panel when all the input terminals of LCD panel are electrically opened.

12. Reliability

Content of Reliability Test (Wide temperature, -20°C~70°C)

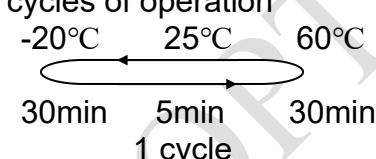
Environmental Test			
Test Item	Content of Test	Test Condition	Note
High Temperature storage	Endurance test applying the high storage temperature for a long time.	80°C 96hrs	2
Low Temperature storage	Endurance test applying the low storage temperature for a long time.	-30°C 96hrs	1,2
High Temperature Operation	Endurance test applying the electric stress (Voltage & Current) and the thermal stress to the element for a long time.	70°C 96hrs	—
Low Temperature Operation	Endurance test applying the electric stress under low temperature for a long time.	-20°C 96hrs	1
High Temperature/ Humidity Operation	The module should be allowed to stand at 60°C,85%RH max	60°C,85%RH 96hrs	1,2
Thermal shock resistance	The sample should be allowed stand the following 10 cycles of operation 	-20°C/60°C 10 cycles	—
Vibration test	Endurance test applying the vibration during transportation and using.	Total fixed amplitude : 1.5mm Vibration Frequency : 10~55Hz One cycle 60 seconds to 3 directions of X,Y,Z for Each 15 minutes	3
Static electricity test	Endurance test applying the electric stress to the terminal.	VS=±600V(contact) , ±800v(air), RS=330Ω CS=150pF 10 times	—

Note1: No dew condensation to be observed.

Note2: The function test shall be conducted after 4 hours storage at the normal Temperature and humidity after remove from the test chamber.

Note3: The packing have to including into the vibration testing.

LCM Sample Estimate Feedback Sheet

Module Number : _____

1 、 Panel Specification :

1. Panel Type :	<input type="checkbox"/> Pass	<input type="checkbox"/> NG , _____
2. View Direction :	<input type="checkbox"/> Pass	<input type="checkbox"/> NG , _____
3. Numbers of Dots :	<input type="checkbox"/> Pass	<input type="checkbox"/> NG , _____
4. View Area :	<input type="checkbox"/> Pass	<input type="checkbox"/> NG , _____
5. Active Area :	<input type="checkbox"/> Pass	<input type="checkbox"/> NG , _____
6. Operating Temperature :	<input type="checkbox"/> Pass	<input type="checkbox"/> NG , _____
7. Storage Temperature :	<input type="checkbox"/> Pass	<input type="checkbox"/> NG , _____
8. Others :	_____	

2 、 Mechanical Specification :

1. PCB Size :	<input type="checkbox"/> Pass	<input type="checkbox"/> NG , _____
2. Frame Size :	<input type="checkbox"/> Pass	<input type="checkbox"/> NG , _____
3. Material of Frame :	<input type="checkbox"/> Pass	<input type="checkbox"/> NG , _____
4. Connector Position :	<input type="checkbox"/> Pass	<input type="checkbox"/> NG , _____
5. Fix Hole Position :	<input type="checkbox"/> Pass	<input type="checkbox"/> NG , _____
6. Backlight Position :	<input type="checkbox"/> Pass	<input type="checkbox"/> NG , _____
7. Thickness of PCB :	<input type="checkbox"/> Pass	<input type="checkbox"/> NG , _____
8. Height of Frame to PCB :	<input type="checkbox"/> Pass	<input type="checkbox"/> NG , _____
9. Height of Module :	<input type="checkbox"/> Pass	<input type="checkbox"/> NG , _____
10. Others :	<input type="checkbox"/> Pass	<input type="checkbox"/> NG , _____

3 、 Relative Hole Size :

1. Pitch of Connector :	<input type="checkbox"/> Pass	<input type="checkbox"/> NG , _____
2. Hole size of Connector :	<input type="checkbox"/> Pass	<input type="checkbox"/> NG , _____
3. Mounting Hole size :	<input type="checkbox"/> Pass	<input type="checkbox"/> NG , _____
4. Mounting Hole Type :	<input type="checkbox"/> Pass	<input type="checkbox"/> NG , _____
5. Others :	<input type="checkbox"/> Pass	<input type="checkbox"/> NG , _____

4 、 Backlight Specification :

1. B/L Type :	<input type="checkbox"/> Pass	<input type="checkbox"/> NG , _____
2. B/L Color :	<input type="checkbox"/> Pass	<input type="checkbox"/> NG , _____
3. B/L Driving Voltage (Reference for LED Type) :	<input type="checkbox"/> Pass	<input type="checkbox"/> NG , _____
4. B/L Driving Current :	<input type="checkbox"/> Pass	<input type="checkbox"/> NG , _____
5. Brightness of B/L :	<input type="checkbox"/> Pass	<input type="checkbox"/> NG , _____
6. B/L Solder Method :	<input type="checkbox"/> Pass	<input type="checkbox"/> NG , _____
7. Others :	<input type="checkbox"/> Pass	<input type="checkbox"/> NG , _____

>> Go to page 2 <<

Module Number : _____

5、Electronic Characteristics of Module :

1.Input Voltage :	<input type="checkbox"/> Pass	<input type="checkbox"/> NG , _____
2.Supply Current :	<input type="checkbox"/> Pass	<input type="checkbox"/> NG , _____
3.Driving Voltage for LCD :	<input type="checkbox"/> Pass	<input type="checkbox"/> NG , _____
4.Contrast for LCD :	<input type="checkbox"/> Pass	<input type="checkbox"/> NG , _____
5.B/L Driving Method :	<input type="checkbox"/> Pass	<input type="checkbox"/> NG , _____
6.Negative Voltage Output :	<input type="checkbox"/> Pass	<input type="checkbox"/> NG , _____
7.Interface Function :	<input type="checkbox"/> Pass	<input type="checkbox"/> NG , _____
8.LCD Uniformity :	<input type="checkbox"/> Pass	<input type="checkbox"/> NG , _____
9.ESD test :	<input type="checkbox"/> Pass	<input type="checkbox"/> NG , _____
10.Others :	<input type="checkbox"/> Pass	<input type="checkbox"/> NG , _____

6、Summary :

Sales signature : _____

Customer Signature : _____

Date : / /