



Technical Data Sheet
RFID reader
MW-D7B
MW-D7G



MW-D7G and MW-D7B

Documentation version: MW-D7x-MAN-V1.6
Date: 28.02.2018
Valid from firmware version: MW-D7x-v1.5.A1.2

2. INTRODUCTION.....	4
3. TECHNICAL DATA.....	5
4. TERMINALS.....	6
5. INPUTS / OUTPUTS.....	7
5.1. Inputs.....	7
5.2. Outputs.....	7
4.4. Signal sources controlling outputs.....	8
4.4.1. Source „0” and source „1”.....	8
4.4.2. Source button.....	8
4.4.3. Source any card.....	9
4.4.4. Source RS_x.....	9
4.4.5. Source PinINx.....	9
4.4.6. Source SIG_Ax.....	9
4.4.7. Source SIG_Bx.....	10
6. DIMENSIONS.....	11
7. INTERFACE.....	12
7.2 COMMUNICATION COMMANDS FOR TRANSPONDERS.....	16
7.2.1 Selecting the transponder type.....	16
7.2.2 Transponder type readout.....	16
7.2.3. On/off switching of reader field.....	17
7.2.4. Reading the ID card unique number.....	17
7.3. COMMANDS FOR COMMUNICATION WITH Q5 TRANSPONDERS.....	18
7.3.1. Writing the ID-Unique number to Q5 transponder.....	18
7.3.2. Sector readout of Q5 transponder.....	18
7.3.3. Writing the sector of Q5 transponder.....	18
7.4 Commands for communication with HITAG transponders.....	19
7.4.1. Reading the page of HITAG transponder.....	19
7.4.2. Page writing to HITAG transponder.....	19
7.4.3. Sleep mode of HITAG transponder.....	19
7.5. Sources, electrical inputs and outputs.....	20
7.5.2. Source status readout.....	20
7.5.3. Writing port configuration.....	21
7.5.4. Port configuration readout.....	21
7.5.5. SIG_A blocks configuration.....	22
7.5.6. SIG_B blocks configuration.....	22
7.5.7. SIG_C blocks configuration.....	24
7.5.8. Colour configuration.....	24
7.6. Access password.....	25
7.6.1. Login to reader.....	25
7.6.2. Password change.....	25
7.6.3. Logout from reader.....	25
7.7. <i>AutoReader</i> mechanism.....	26
7.7.1 Saving machine configuration.....	26
7.7.2. Configuration readout from the machine.....	28
7.8. Other Commands.....	28
7.8.1. Remote reader reset.....	28
7.8.2. Readout of a reader firmware version.....	28
7.9. Meaning of operation codes in response frames.....	29
8. RETURN TO FACTORY SETTINGS.....	30
9. BOOTLOADER – UPDATE DEVICE FIRMWARE.....	32

2. Introduction

MW-D7x is a wall-mounted reader of RFID cards which works on 125kHz rated frequency

Main features:

- Support of Unique, Q5, Hitag or HID transponders,
- Interfaces:
 - RS232
 - RS485
 - 1-WIRE
 - WIEGAND
- Built-in buzzer,
- Built-in LED RGB of common purpose
- Button
- Available in colors:
 - black (MW-D7B)
 - grey (MW-D7G)

3. Technical Data

Supported functionality depending on transponder / card type:			
Transponder type	ID number readout	Full writing and readout of memory blocks	Writing and readout using encryption
Unique	YES	-	-
Q5	YES	YES	-
HID	YES	-	-
HITAG	YES	YES	NO

MW-D7x reader parameters:	
Supply voltage	7-15V
Max. supply current	120 mA
Rated operation radio frequency of module	125 kHz
Read-out distance of transponders	Up to 8 cm
Dimensions(wid.*len.*heig)	44x83x14 mm
Front button	
Interfaces	RS-232 RS-485 Wiegand 1-WIRE
Input/Output	Anticollision (In/Out) PinOUT (Out) PinIN0 (In) PinIN1 (In)
Operating temperature	0-60°C

4. Terminals

Wire	Name	Function
Red	VCC	VCC (+)
Blue	GND	GND (-)
White	Anticollision	Output for connecting readers with each other, that are operating closely together
Brown	PinOUT	Output for any purpose
Green	PinINTERFACE1	Serial interface line (RS232_TX, RS485_B, WIEGAND0, 1WIRE)
Yellow	PinINTERFACE2	Serial interface line (RS232_RX, RS485_A, WIEGAND1)
Grey	PinIN0	Input for any purpose
Pink	PinIN1	Input for any purpose

5. Inputs / Outputs

5.1. Inputs

Reader MW-D7x has three inputs:

1. PinIN0
2. PinIN1
3. Button

5.2. Outputs

Reader MW-D7x has six outputs:

1. Kolor0 (LED RGB)
2. Kolor1 (LED RGB)
3. Kolor2 (LED RGB)
4. Kolor3 (LED RGB)
5. Buzzer
6. PinOUT

WARNING:

The active state of the output buzzer locks transponders readings'.

4.3. RGB LED

Reader MW-D7x using LEDs can display 4 colors: white, green, red and blue. Colour codes are shown in the table below:

Table 4.1 Colour codes table

Colour code	Colour
0	Red
1	Green
2	Blue
3	White

Assigning a specific colour to the KolorX output can be done with the *SIG_C block configuration* command.

Command frame:

C_ConfigSIG_C	No, [Source, Time]
---------------	--------------------

Parameters: Source, Time are optional and if they occur, then a new configuration will be written.

Family code	Address	
C_ConfigSIG_C	Read/write SIG_C configuration block	0x62
No	SIG_C block number	0x00..0x03
Source	Control signal source	See ID number from Table 4.2 Signal sources
Time	Filtering time (x100ms)	0-255

Response frame:

C_ConfigSIG_C+1	No, Source, Time
-----------------	------------------

Where:

Meaning of response parameters is identical to those described earlier.

Colour configuration. When determining which colour is to be displayed, Kolor0 input has highest priority and Kolor3 has the lowest priority.

4.4. Signal sources controlling outputs

MW-D7x reader has 18 sources of logical signals. These signals can be used to control outputs. The table below contains a list of all sources and values of signals generated by them.

Table 4.2 Signal sources

ID	Nazwa	Opis
0	„0”	Signal source with value of 0
1	„1”	Signal source with value of 1
2	Button	Source reflecting the status of the front button. It has value of 1 when the button is pressed and value of 0 otherwise
3	Every card	Source reflecting information about the presence of the card in the field. It has value of 1 when the card is the field and value of 0 otherwise
4	RS_0	Sources controlled via RS232 serial interface. See <i>C_WriteOutput command</i> .
5	RS_1	
6	RS_2	
7	RS_3	
8	PinIN0	Sources controlled by a physical input pin using the INPUT block
9	PinIN1	
10	SigA0	Sources controlled by SIG_Ax block outputs
11	SigA1	
12	SigA2	
13	SigA3	
14	SigB0	Sources controlled by SIG_Bx block outputs
15	SigB1	
16	SigB2	
17	SigB3	
18	SigC0	Sources controlled by SIG_Cx block outputs
19	SigC1	
20	SigC2	
21	SigC3	

4.4.1. Source „0” and source „1”

Signal source „0” has always value of 0, while the signal source “1” has the value of 1.

4.4.2. Source button

Source reflecting the status of the front button. It has the value 1 when the button is

pressed and the value 0 otherwise.

ATTENTION:

If a button is pressed for more than 3 minutes, it will be recalibrated and source value reset to zero

4.4.3. Source any card

Source reflecting information about the presence of card in the field of the reader. It has the value 1 when the card is in the field and the value 0 in the opposite case.

4.4.4. Source RS_x

Sources controlled via RS232 serial interface. The source enables

- Setting the value 0
- Setting the value 1
- Setting the value 1 to a specified time, after which the source will automatically change the state to 0.

See Rsx source state writing command

4.4.5. Source PinINx

PinINx sources are controlled through physical inputs. Depending on the configuration, the source value has the value:

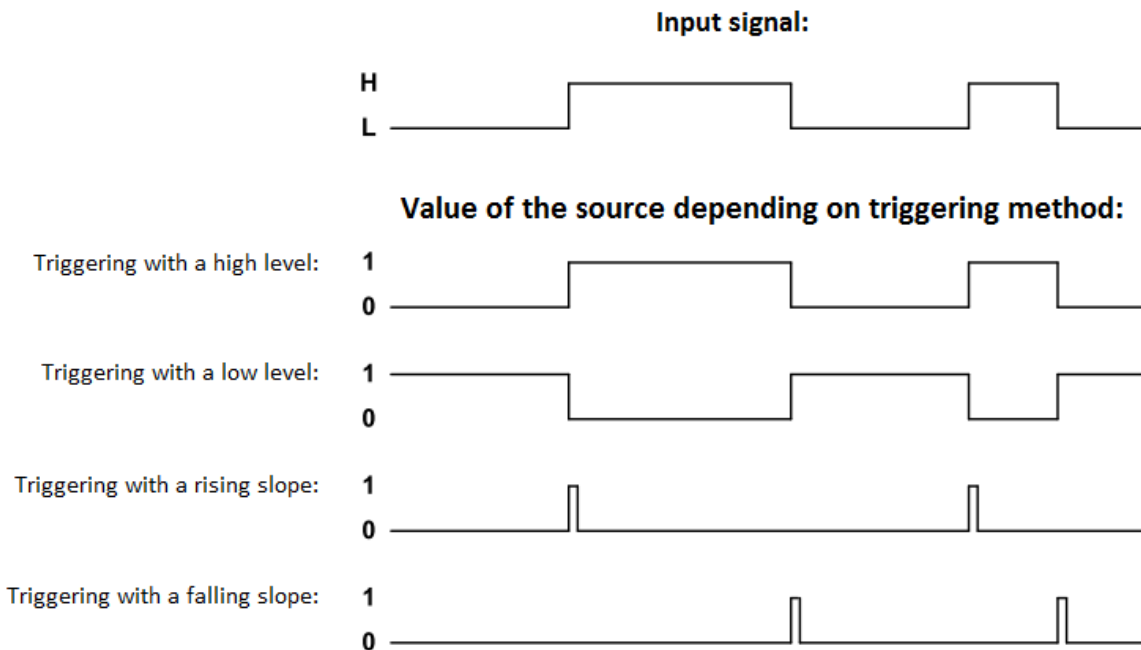

Configuration of the trigger method is done using Port configuration writing command.

4.4.6. Source SIG_Ax

MW-D7X reader has 4 virtual SIG_A blocks that allow you to perform logical operations on signals. Each block has 3 signal outputs, one function selection input and one output. Any signal source can be connected to the signal inputs of blocks. At the block output, depending on the *Fun* function selected, there will be a logical sum or logical product of input signals. The SIG blocks are configured using the *SIG_A block configuration* command.

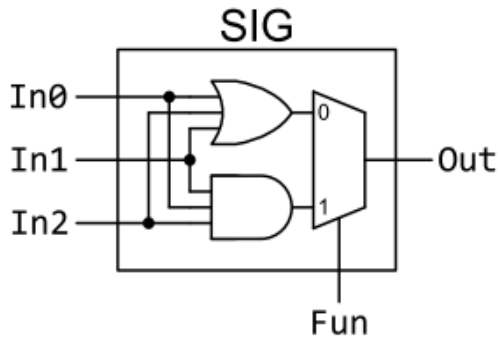

4.4.7. Source SIG_Bx

MW-D7X reader has 4 virtual SIG_B blocks that allow you to perform logical operations on signals. SIG_B block configuration is done using *SIG_B block configuration* command.

4.4.8. Source SIG_Cx

MW-D7X reader has 4 virtual SIG_C blocks that allow you to perform filtering of logical signals. State at the SIG_C output will change to the same as at input if the input state remains constant for the time defined by Time parameter. Configuration of SIG_C blocks is performed using SIG_B block configuration command.

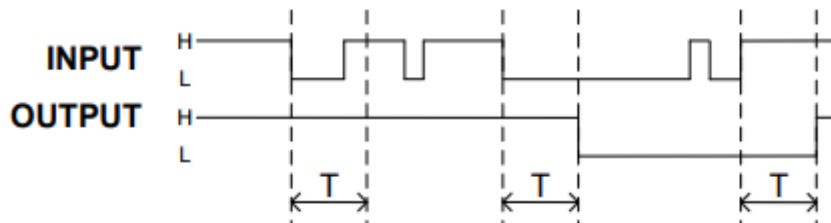

4.1 Example of input and output course for SIG_C block

6. Dimensions

Dimensions of the reader are shown in the figure below:

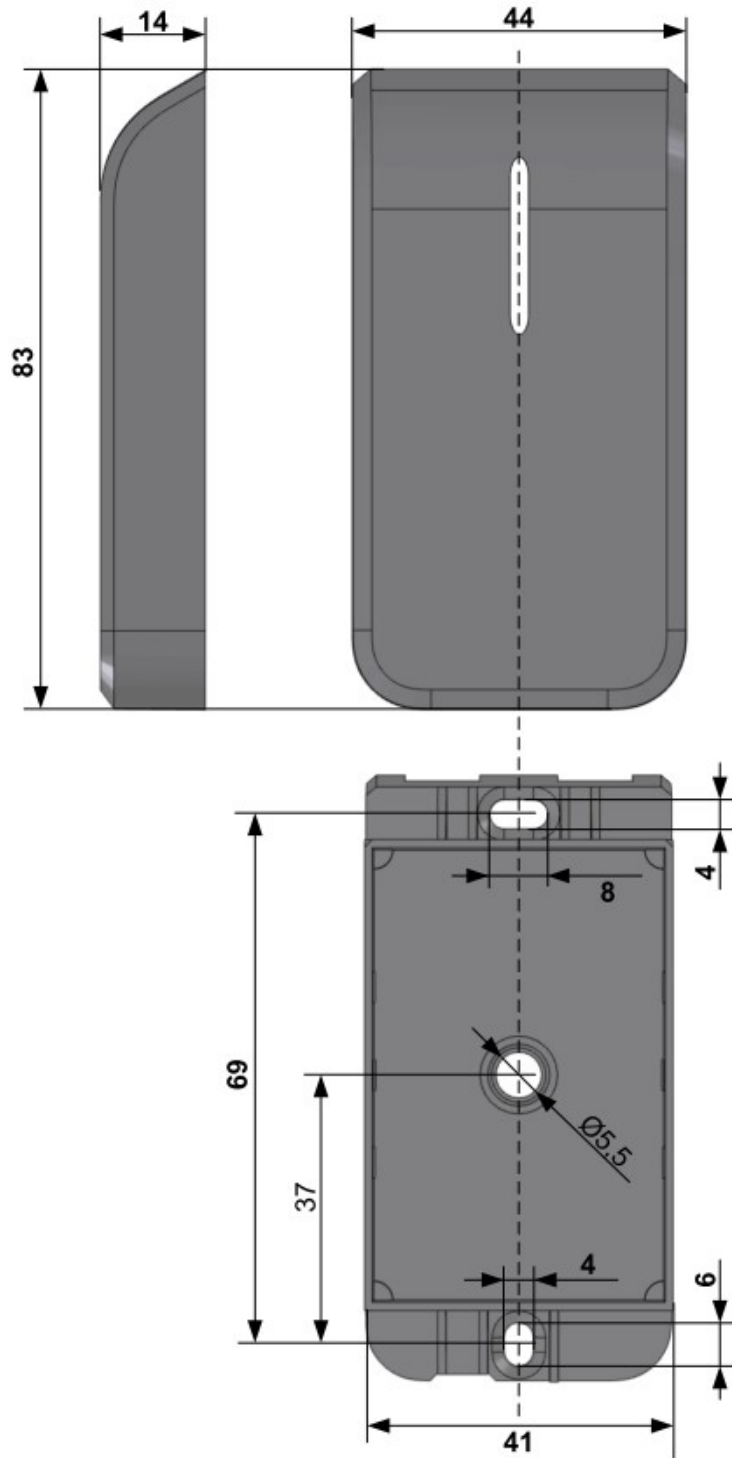

Cable length: 30cm

7. Interface

MW-D7x reader supports 4 serial interfaces:

- RS232
- RS485
- 1-WIRE
- Wiegand

RS-232 and RS-485 interfaces are constantly listening in anticipation of the command. AutoReader sends the read ID via the interface selected in the AutoReader configuration.

6.1. Interface 1-WIRE

After configuring the device to work in 1-WIRE mode, the reader emulates Dallas DS1990 series of “pills”. As long as the card is in the field, reader will issue a unique number on the 1-WIRE bus. The format of the sent ID has the form:

Family code	Transponder ID					Address	CRC
ConfFC	ID0	ID1	ID2	ID3	ID4	ConfAdr	xx

To change a parameter *Address* or *Family code*, please send a *C_SetInterfaceConfig* command to the reader.

6.2. Interface WIEGAND

Reader, after being configured to operate in WIEGAND mode, sends a unique ID number of the read card in accordance with the Wiegand protocol with the following parameters:

Pulse duration (L level) 100us
 Interval between impulses (H level) 1ms

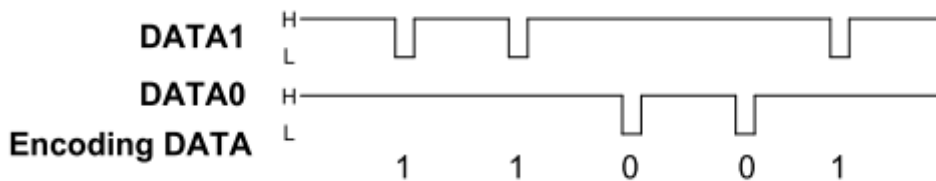

MW-D7x reader allows you to change the WIEGAND frame length and to select the part of the ID card to be sent on the main line (bus).

Example:

Card ID = 0x123456789A = 0b0001001000110100010101100111100010011010

WIEGAND parameters	Card ID / corresponding WIEGAND frame	
P1=26, P2=0	0b0001001000110100010101100111100010011010 P000100100011010001010110N	Card ID WIEGAND frame
P1=37, P2=0	0b0001001000110100010101100111100010011010 P00010010001101000101011001111000100N	Card ID WIEGAND frame
P1=26, P2=1	0b0001001000110100010101100111100010011010 P010101100111100010011010N	Card ID WIEGAND frame

P,N – parity bits

Another format e.g. WIEGAND, can be obtained by changing the configuration (Writing configuration of serial interface).

6.3. Interface RS232 / RS485

MW-D7X reader, regardless of the configured interface, always listens to commands sent via RS232 or RS485 interface.

In this document, the description of the protocol has been limited to the description of orders, responses and their parameters. The headline and CRC checksum are always present and are consistent with the full “Netronix Protocol” documentation.

Command frame:

Header	C_CommandName	Command_parameters 0...n	CRC
--------	---------------	--------------------------	-----

Response frame:

Header	C_CommandName +1	Response_parameters 0...m	OperationCode	CRC
--------	------------------	---------------------------	---------------	-----

Serial protocol operation can be tested by means of development tools including free of charge “FRAMER” software”.

For device configuration, you can use free NEFIG software.

7. Commands available for RS232/RS485 interface

7.1. Serial interface configuration

7.1.1. Configuration record of serial interface

Command frame:

C_SetInterfaceConfig	Typ, P1, P2
----------------------	-------------

Where:

Parameter name	Description	Value range
C_SetInterfaceConfig	Command for changing the serial interface settings	0x54
Typ	Interface type	0 – RS232 1 – RS485 2 – 1-WIRE 3 – WIEGAND
P1, P2	Parameters depending on value Type: For Typ=0 P1 - logical address (RS232) P2 - transmission speed (RS232) For Typ=1 P1 - logical address (RS485) P2 - transmission speed (RS485) For Typ=2 P1 - ConfAdr (7 th byte of Dallas frame) P2 - ConfFC (1 st byte of Dallas frame) For Typ=3 P1 - number of bits P2 – L/M. Switch determines which part of card ID will be sent in the WIEGAND frame.	P1: 0x01 - 0xFE P2: - See Table 7.1 P1: 0x01 - 0xFE P2: - See Table 7.1 P1: 0x00 - 0xFF P2: 0x00 - 0xFF P1: 26 - 37 P2: 0-1

Table 7.1 RS232 interface speed

ID	Speed
0	1200 bps
1	2400 bps
2	4800 bps
3	9600 bps
4	19200 bps
5	38400 bps
6	57600 bps
7	115200 bps

Response frame:

C_SetInterfaceConfig +1	Operation Code
-------------------------	----------------

7.1.2. Configuration reading of serial interface

Command frame:

C_GetInterfaceConfig	Typ
----------------------	-----

Where:

Parameter name	Description	Value range
C_GetInterfaceConfig	Command for changing the serial interface settings	0x56
Typ	Type of interface which configurations we want to read	0 – RS232 1 – RS485 2 – 1-WIRE 3 – WIEGAND

Response frame:

C_GetInterfaceConfig+1	Typ, P1, P2
------------------------	-------------

Where:

Parameter name	Description	Value range
C_GetInterfaceConfig+1	Command for changing the serial interface settings	0x57
Typ	Interface type	0 – RS232 1 – RS485 2 – 1-WIRE 3 – WIEGAND
P1, P2	Parameters depending on value Type: For Typ=0 or Typ=1 P1 - device logical address P2 - transmission speed For Typ=1 P1 - Address (7 th byte of Dallas frame) P2 - Family (1 st byte of Dallas frame) For Typ=2 P1 - number of bits P2 – L/M	P1: 0x01-0xFE P2: - See Table 7.1 P1: 0x00-0xFF P2: 0x00-0xFF P1: 26-37 P2: 0-1

7.2 Communication commands for transponders

7.2.1 Selecting the transponder type

Command frame:

C_SetTransponderType	TransponderType, GAIN
----------------------	-----------------------

Where:

Parameter name	Description	Value range
C_SetTransponderType	Command of transponder type changing	0x02
TransponderType	Transponder type we want to exchange data with	0x01 – Unique 0x02 – Q5 0x03 – HITAG 0x04 – HID

Response frame:

C_SetTransponderType +1		Operation Code
-------------------------	--	----------------

7.2.2 Transponder type readout

Command frame:

C_GetTransponderType	TransponderType, GAIN
----------------------	-----------------------

Where:

Parameter name	Description	Value range
C_GetTransponderType	Transponder type readout command	0x04

Response frame:

C_GetTransponderType +1	TransponderType	Operation Code
-------------------------	-----------------	----------------

Where:

Parameter name	Description	Value range
C_SetTransponderType+1	Transponder type readout command	0x05
TransponderType	Identifier of transponder type with which we intend to exchange data	0x01 – Unique 0x02 – Q5 0x03 – HITAG 0x04 – HID

7.2.3. On/off switching of reader field

Command frame:

C_TurnOnAntennaPower	State
----------------------	-------

Where:

Parameter name	Description	Value range
C_TurnOnAntennaPower	On/off switching of reader field	0x10
State	State	0x00 – switching the field off 0x01 – switching the field on

Response frame:

C_TurnOnAntennaPower +1		Operation Code
-------------------------	--	----------------

7.2.4. Reading the ID card unique number

Command frame:

C_Select	
----------	--

Where:

Parameter name	Description	Value range
C_Select	ID readout	0x12

Response frame:

C_Select +1	Coll, TType, ID1.....IDn	Operation Code
-------------	--------------------------	----------------

Where:

Parameter name	Description	Value range
Coll	Collision information (HITAG transponders only)	0 – no collision 1 – collision of two or more transponders
TType	Information about the type of transponder from which the read ID number comes from	1 - Unique,Q5 3 - HITAG 4 - HID
ID1...IDn	Unique transponder number	ID1 – LSB, IDn – MSB

7.3. Commands for communication with Q5 transponders

After selecting the Q5 type transponder, we have new commands at disposal, which will be used for two-way communication.

7.3.1. Writing the ID-Unique number to Q5 transponder

Command frame:

C_UniqueWrite	Unique1..5, lock
---------------	------------------

Where:

Parameter name	Description	Value range
C_UniqueWrite	Writing command of id-unique	0x08
Unique1..5	5 bytes of ID number	0x00-0xff
lock	ID programming with rewrite lock	0 – without lock 1 – with lock

Response frame:

C_UniqueWrite +1		Operation Code
------------------	--	----------------

NOTE: The Q5 type transponders do not have verification function of correct ID number writing. Getting proper code of operation does not guarantee correct assign of ID number. Make sure, that ID number has been assigned correctly reading the number with *C_Select* command.

7.3.2. Sector readout of Q5 transponder

Command frame:

C_ReadData	SectorNo,[Password1..4]
------------	-------------------------

Gdzie:

Parameter name	Description	Value range
C_ReadData	Sector read command	0x1E
SectorNo	Read sector number	0x00-0x07
Password	Option - if sector which is being read is 4-byte password protected	0x00-0xff

Response frame:

C_ReadData +1		Operation Code
---------------	--	----------------

7.3.3. Writing the sector of Q5 transponder

Command frame:

C_WriteData	SectorNo, Data1...4, Lock,[Password1..4]
-------------	--

Where:

Parameter name	Description	Value range
C_WriteData	Sector writing command	0x1C
SectorNo	Sector writing number	0x00-0xff

Data1..4	4 bytes of data	0x00-0x07
lock	Programming the sector with rewrite lock	0 – without lock 1 – with lock
Password1..4	Option – if we want to protect a sector with 4-byte password	0x00-0xff

Response frame:

C_WriteData+1		Operation Code
---------------	--	----------------

NOTE: The Q5 type transponders do not have verification function of correct data write into sectors. Getting proper code of operation does not guarantee correct write. Make sure, that data has been written correctly reading it with *C_ReadBlock* command.

7.4 Commands for communication with HITAG transponders

7.4.1. Reading the page of HITAG transponder

Command frame:

C_ReadData	PageNo
------------	--------

Where:

Parameter name	Description	Value range
C_ReadData	Page readout command	0x1E
PageNo	Page readout number	0x00-0x3f

Response frame:

C_ReadData +1		KodOperacji
---------------	--	-------------

7.4.2. Page writing to HITAG transponder

Command frame:

C_WriteData	PageNo, Data1...4
-------------	-------------------

Where:

Parameter name	Description	Value range
C_WriteData	Writing page command	0x1C
PageNo	Writing page number	0x00-0x3f
Data1..4	4 bytes of data	0x00-0xff

Response frame:

C_WriteData +1		OperationCode
----------------	--	---------------

7.4.3. Sleep mode of HITAG transponder

When operating with multiple HITAG transponders at the same time, it is necessary to enter unused transponders into sleep mode with *C_Halt* command.

Command frame:

headline	C_Halt		CRC
----------	--------	--	-----

Where:

Parameter name	Description	Value range
C_Halt	Transponder sleep mode command	0x40

Response frame:

headline	C_Halt+1	Operation Code	CRC

7.5. Sources, electrical inputs and outputs

7.5.1. Writing RSx source state

Command frame:

headline	C_WriteSourceRSx	IONo, State, [Time]	CRC

Gdzie:

Nazwa parametru	Opis parametru	Zakres wartości
C_WriteSourceRSx	Record of Rsx source state	0x70
Source	Number of RSx source	0x04-0x07
State	Desired output status	0x00 lub 0x01
[Time]	Optional parameter. Time after which Rsx source will return to state 0 (x10ms)	0x00-0xFF

Response frame:

headline	C_WriteSourceRSx+1	Operation Code	CRC

7.5.2. Source status readout

Command frame:

headline	C_ReadSource	Source	CRC

Where:

Parameter name	Opis parametru	Zakres wartości
C_ReadSource	Source status readout	0x72
Source	Source value	See ID number from <i>Table 4.2 Signal sources</i>

Response frame:

headline	C_ReadSource +1	State	Operation Code	CRC

Parameter name	Opis parametru	Zakres wartości
C_ReadSource+1	Source status readout	0x73
State	Source value	0x04-0x07

7.5.3. Writing port configuration

Command frame:

C_SetIOConfig	IONo, Dir, P0
---------------	---------------

Where:

When configuring port as an output:

Parameter name	Description	Value range
C_SetIOConfig	Writing any port configuration	0x50
IONo	IO port number to be configured	0x00..0x05
Dir	Port direction	0x00 – output
P0	Control signal source	See ID number from Table 4.2 Signal sources

When configuring port as an input:

Parameter name	Description	Value range
C_SetIOConfig	Writing any port configuration	0x50
IONo	IO port number to be configured	0x06 – 0x07
Dir	Port direction	1 – input
P0	Byte specifying triggering method. See chapter: 4.4.5 PinINx source	0 – not negated 1 – negated 2 – reaction to rising slope 3 – reaction to falling slope

Not all MW-D7x ports have any direction. For proper configuration, correct direction should be given for the port.

Table 7.2 List of existing ports that can be controlled in MW-D7x

Port number	Direction	Description
0	output	PinOUT Physical output
1	output	KOLOR0
2	output	KOLOR1
3	output	KOLOR2
4	output	KOLOR3
5	output	BUZZER
6	input	PinIN0 Physical input
7	input	PinIN1 Physical input

Response frame:

headline	C_SetIOConfig +1		Operation Code	CRC
----------	------------------	--	----------------	-----

7.5.4. Port configuration readout

Command frame:

headline	C_GetIOConfig	IONo	CRC
----------	---------------	------	-----

Where:

Parameter name	Description	Value range
C_GetIOConfig	Port configuration readout	0x52
IONo	IO port number whose configuration is to be read	0x00...0x07

Response frame:

headline	C_GetIOConfig +1	Dir, P0	Operation Code	CRC
----------	------------------	---------	----------------	-----

Where:

Parameter name	Description	Value range
Dir, P0	Parameters have the same form as when saving the configuration	

7.5.5. SIG_A blocks configuration

Command frame:

headline	C_ConfigSIG_A	SigNo, [Function, In0, In1, In2]	CRC
----------	---------------	----------------------------------	-----

Where:

Parameter name	Description	Value range
C_ConfigSIG_A	Read/write configuration of SIG_A block	0x5C
SigNo	SIG_A block number , whose configuration is to be read / written	0x00...0x03
Function	Optional parameter – if present, the command saves new configuration. It specifies the type of function executed by SIG_A block.	0 – OR function 1 – AND function
In1, In2, In3	Optional parameter – if present, the command saves new configuration. Sources of input signals.	See ID number from <i>Table 4.2 Signal sources</i>

Response frame:

headline	C_ConfigSIG_A +1	Function, In0, In1, In2	Operation Code	CRC
----------	------------------	-------------------------	----------------	-----

Where:

Meaning of response parameters is identical to those described earlier.

7.5.6. SIG_B blocks configuration

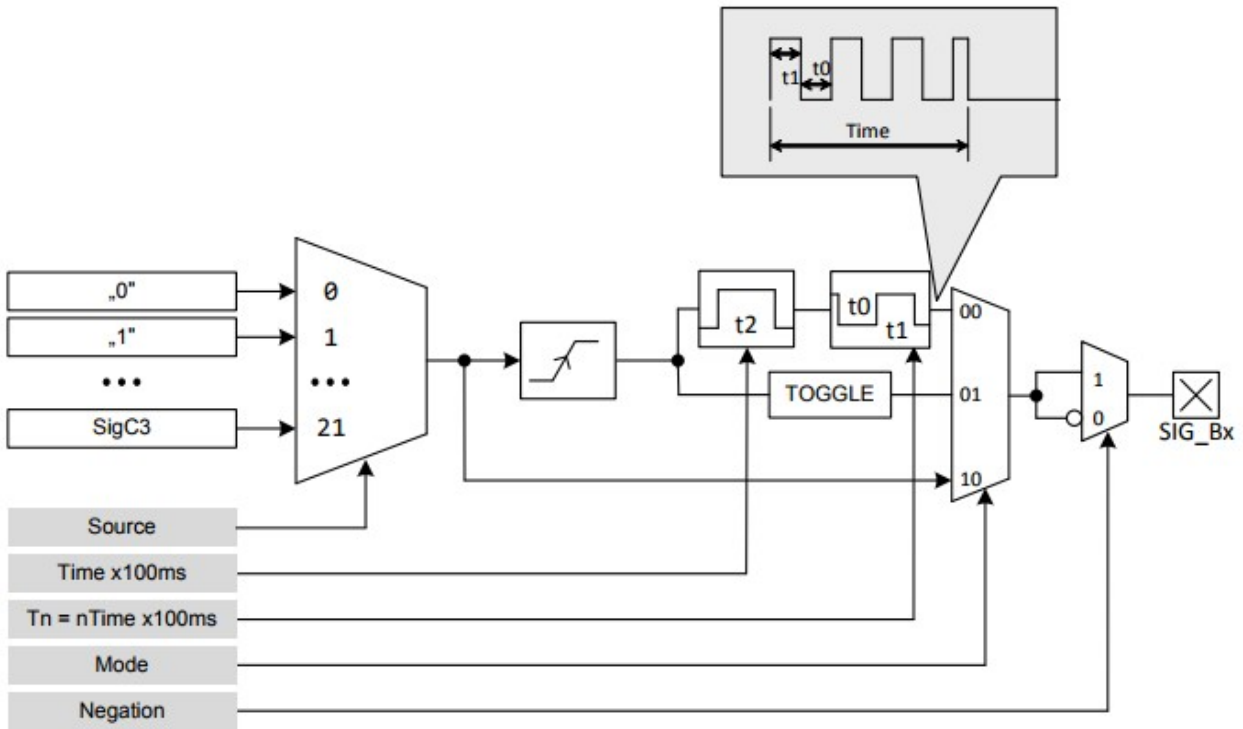

Command frame:

C_ConfigSIG_B	No, [Source, Mode, Negation, Time, 0Time, 1Time]
---------------	--

Parameters: Source, Mode, Negation, Time, 0Time, 1Time are optional and if present, new configuration will be saved.

Parameter name	DescriptionRead/write configuration of SIG_A block	Value range
C_ConfigSIG_C	Read/write configuration of SIG_B block	0x60
No	SIG_B block number	0x00..0x03
Source	Source of control signal	See ID number from <i>Table 4.2 Signal sources</i>
Mode	Determines output behaviour	00 – square wave generator 01 – change in output status to the opposite of previous state 10 – directly
Negation	Output negation	0 – negated output 1 – direct output
Time	Runtime of switching state after activation stops. This time is expressed as: Runtime x 100ms. During "Runtime", you can configure the output that can generate a square wave. Time of '1' and '0' is set by the following parameters: 0Time and 1Time	0 – 255

0Time	Logical '0' time	0 – 255
1Time	Logical '1' time	0 – 255

Response frame:

C_ConfigSIG_B+1	No, Source, Mode, Negation, Time, 0Time, 1Time
-----------------	--

Where:

Meaning of response parameters is identical to those described earlier.

7.5.7. SIG_C blocks configuration

Command frame:

C_ConfigSIG_C	No, [Source, Time]
---------------	--------------------

Parameters: *Source*, *Time* are optional and if present, new configuration will be saved.

Parameter name	Description	Value range
C_ConfigSIG_C	Read/write configuration of SIG_C block	0x62
No	SIG_B block number	0x00..0x03
Source	Source of control signal	See ID number from <i>Table 4.2 Signal sources</i>
Time	Filtering time (x100ms)	0-255

Response frame:

C_ConfigSIG_C+1	No, Source, Time
-----------------	------------------

Where:

Meaning of response parameters is identical to those described earlier.

7.5.8. Colour configuration

Command frame:

headline	C_ConfigLed	[C0, C1, C2, C3]	CRC
----------	-------------	------------------	-----

Where:

Parameter name	Description	Value range
C_ConfigLed	Read/Write displayed colour configuration	0x5E
[C0,C1, C2, C3]	Optional parameters – if present, the command writes new configuration. C0 – kolor0 code, priority 1 (highest) C1 – kolor1 code, priority 2 C2 – kolor2 code, priority 3 C3 – kolor3 code, priority 4 (lowest)	See: <i>Table 4.1 Colour codes table</i>

Response frame:

headline	C_ConfigLed +1	C0, C1, C2, C3	Operation Code	CR
----------	----------------	----------------	----------------	----

Where:

Meaning of response parameters is identical to those described earlier.

7.6. Access password

7.6.1. Login to reader

Command frame:

headline	C_LoginUser	Data1...n, 0x0		CRC
----------	-------------	----------------	--	-----

Where:

Parameter name	Description	Value range
C_LoginUser	Login to reader	0xb2
Data1...n	Any byte string	Any of ranges 0x01 ... 0xff. String length can be from 0 to 8 bytes
0x00	'0' ending the string	0x00

Response frame:

headline	C_LoginUser+1		Operation Code	CRC
----------	---------------	--	----------------	-----

7.6.2. Password change

Command frame:

headline	C_ChangeLoginUser	Data1...n, 0x0		CRC
----------	-------------------	----------------	--	-----

Where:

Parameter name	Description	Value range
C_ChangeLoginUser	Password change	0xb4
Data1...n	Any byte string, that will be valid access password	Any of ranges 0x01 ... 0xff. Chain length can be from 0 to 8 bytes
0x00	'0' ending the string	0x00

If Data1 = 0x00, then the reader will not be password protected. You can set a new password at any time so that the reader will be protected by a password.

Response frame:

headline	C_ChangeLoginUser+1		Operation Code	CRC
----------	---------------------	--	----------------	-----

7.6.3. Logout from reader

The order will void last password you provided.

Ramka rozkazu:

headline	C_LogoutUser		CRC
----------	--------------	--	-----

Where:

Parameter name	Description	Value range
C_LogoutUser	Logout from reader	0xd6

Response frame:

headline	C_LogoutUser +1		Operation Code	CRC
----------	-----------------	--	----------------	-----

7.7. *AutoReader* mechanism

7.7.1 Saving machine configuration

This command configures the operating mode of machine reading unique UID transponder number.

Described reader gives you opportunity to temporarily suspend machine operation in case of proper transmission on the RS link.

If reader works in mixed mode, i.e.

- UID reading machine is running, and:
- the master device (computer, controller) communicates with a reader or with use of a transponder reader,

it is necessary to properly configure a reader so that in the case of transmissions with a reader or with a transponder, the reading machine suspends its work.

Ramka rozkazu:

headline	C_SetAutoReaderConfig	ATrig, AOfflineTime, Aserial, AMode, Abuzz, Amulti, AInterface	CRC
----------	-----------------------	--	-----

Where:

Parameter name	Description	Value range
C_SetAutoReaderConfig	Saving machine configuration	0x58
ATrig	Defines when a UID reading machine should operate	0 - machine switched off permanently 1 - machine switched on permanently 2 - is activated automatically when there is no transmission on RS / USB for a longer period than AOfflineTime 3 - turns on automatically when there are no commands for communication with a transponder for longer period than AOfflineTime

<p>AOfflineTime</p>	<p>'No transmission' time on RS / USB $T = AofflineTime * [100\ ms]$ No transmission can refer to any commands (Atrig = 2), or commands to communicate with a transponder (Atrig = 3). Communication commands with a transponder are: C_TurnOnAntennaPower C_Select</p>	<p>0x00...0xff</p>												
<p>ASerial</p>	<p>Automatic sending of a UID transponder number after automatic reading from a transponder</p>	<p>0 - never 1 – only first time transponder application 2 – sends everything</p>												
<p>AMode</p>	<p>Configurational byte determining sent ID format</p> <p>Format:</p> <table border="1" data-bbox="513 1039 1002 1142"> <tr> <td colspan="3">MSB</td> <td colspan="3">LSB</td> </tr> <tr> <td>I</td> <td>E</td> <td>F<1,0></td> <td>C<1,0></td> <td>D</td> <td>ID</td> </tr> </table> <p>ATTENTION: 'E' bytes and F<1,0> only matters for Ainterface = 0 or Ainterface=1. C1, C0, D bytes only matters for ASCII format (F<1,0>=1)</p>	MSB			LSB			I	E	F<1,0>	C<1,0>	D	ID	<p>I=1 – number in reverse order E=1 - extended information about collision signaling and card type F<1,0>=0 – ID in Netronix frame format F<1,0>=1 – ID in ASCII format F<1,0>=2 – ID in binary format</p> <p>C<1,0>=0 – without the end of line mark C<1,0>=1 – CR end mark C<1,0>=2 – LF end mark C<1,0>=3 – CRLF end mark</p> <p>ID - extended information about the reader's address set for the RS485 bus</p>
MSB			LSB											
I	E	F<1,0>	C<1,0>	D	ID									
<p>ABuzz</p>	<p>Automatic readout signaling using buzzer after automatic UID readout from a transponder</p>	<p>0 - never 1 - only first time transponder application 2 – signals all</p>												
<p>AMulti</p>	<p>Readout mode of many transponder types</p>	<p>0 – reads only the selected transponder type with the CSetTransponderType command 0xff-reads all supported transponder types</p>												
<p>AInterface</p>	<p>Choosing the interface after which the autoreader machine sends the read ID</p>	<p>0 – RS232 1 – RS485 2 – 1-WIRE</p>												

Response frame:

headline	C_SetAutoReaderConfig +1		Operation Code	CRC
----------	--------------------------	--	----------------	-----

7.7.2. Configuration readout from the machine

Command frame:

headline	C_GetAutoReaderConfig			CRC
----------	-----------------------	--	--	-----

Gdzie:

Nazwa parametru	Opis parametru	Zakres wartości
C_GetAutoReaderConfig	Configuration readout from the machine	0x5a

Response frame:

headline	C_GetAutoReaderConfig +1	ATrig, AOfflineTime, ASerial, AMode, Abuzz, AMulti	Operation Code	CRC
----------	--------------------------	--	----------------	-----

Where:

Meaning of response parameters is identical to those described earlier.

7.8. Other Commands

7.8.1. Remote reader reset

Command frame:

headline	C_Reset			CRC
----------	---------	--	--	-----

Where:

Nazwa parametru	Opis parametru	Zakres wartości
C_Reset	Remote reset of reader	0xd0

Response frame:

headline	C_Reset +1		Operation Code	CRC
----------	------------	--	----------------	-----

7.8.2. Readout of a reader firmware version

Command frame:

headline	C_FirmwareVersion			CRC
----------	-------------------	--	--	-----

Where:

Nazwa parametru	Opis parametru	Zakres wartości
C_FirmwareVersion	Readout of reader firmware version	0xfe

Response frame:

headline	C_FirmwareVersion+1	Data1.....n	Operation Code	CRC
----------	---------------------	-------------	----------------	-----

Where:

Data1...n is a string of characters stored in the form of ASCII codes.

7.9. Meaning of operation codes in response frames

Table 7.3 Operation codes

Nazwa kodu operacji	Opis	Wartość
OC_Error	error	0x00
OC_ParityError	Parity error	0x01
OC_RangeError	Range error	0x02
OC_LengthError	Amount of data error	0x03
OC_ParameterError	Parameter error	0x04
OC_Busy	Temporary occupation of internal modules	0x05
OC_NoACKFromSlave	Lack of internal communication	0x22
OC_CommandUnknown	Unknown command	0x07
OC_WrongPassword	Wrong password or last password has expired, i.e. an automatic LogOut has taken place	0x09
OC_NoCard	No transponder	0x0a
OC_BadFormat	Bad data format	0x18
OC_FrameError	Transmission error. It can indicate existing faults	0x19
OC_NoAnswer	No response from transponder	0x1E
OC_TimeOut	Operation time exceeded. It can indicate a lack of transponder in the reader field	0x16
OC_Successful	Operation completed successfully	0xFF

8. Return to factory settings

To return to factory settings, within 3 to 10 seconds after starting a device, press the the front button for approx. 3 seconds. When returning to factory settings, the following reader parameters are permanently set:

Table 8.1 Factory settings

Parameter name or functionality	Value or setting	
Interface		
RS232 interface	Address: 0x01 Speed: 0x03	9600bps
RS485 interface	Address: 0x01 Speed: 0x03	9600bps
1-WIRE interface	Family: 0x01 Address: 0x00	
Wiegand interface	Byte quantity: 37	
Transponder readout		
Transponder type	0x01	UNIQUE
Autoreader	Trigger: 0x02	
	Timeout: 0x14	2s
	Mode: 0xFF	All supported types
	Aserial: 0x01	on first application
	Amode: 0x40	Netronix format, extended information about collision signals and card type
	Abuzzer: 0x01	On first application
	ALinterface: 0x00	RS232
Inputs/Outputs		
PinIN0 input	Trigger: low state	
PinIN1 input	Trigger: low state	
PinOUT output	Source control: Button	
Kolor0 output	Source control: PinIN1	
Kolor1 output	Source control: Button	
Kolor2 output	Source control: '0'	
Kolor3 output	Source control: '1'	
Buzzer output	Source control: PinIN0	
Colour setting		
LED configuration	C0: GREEN C1: BLUE C2: WHITE C3: RED	

SIGNAL blocks		
SigA0	In0: "0"; In1: "0"; In2: "0"; Function: OR	
SigA1	In0: "0"; In1: "0"; In2: "0"; Function: OR	
SigA2	In0: "0"; In1: "0"; In2: "0"; Function: OR	
SigA3	In0: "0"; In1: "0"; In2: "0"; Function: OR	
SigB0	Source: "0", Mode: 2, Negation: 1 Time:0, Time0: 0, Time1: 0	
SigB1	Source: "0", Mode: 2, Negation: 1 Time:0, Time0: 0, Time1: 0	
SigB2	Source: "0", Mode: 2, Negation: 1 Time:0, Time0: 0, Time1: 0	
SigB3	Source: "0", Mode: 2, Negation: 1 Time:0, Time0: 0, Time1: 0	
Password		
Password	"" , 0x3C	No password, 60s

9. Bootloader – update device firmware

In order to upload new firmware to the device, follow the procedure:

1. Connect the device to the RS232 serial port on your computer
2. Run the program *NEFIR.exe*
3. Set the correct COM port and baud rate to 9600bps
4. Press *Open HEX File* button and load the file with the new firmware
5. Press the **START** button, which triggers the reloading firmware
6. Wait for the end of the process

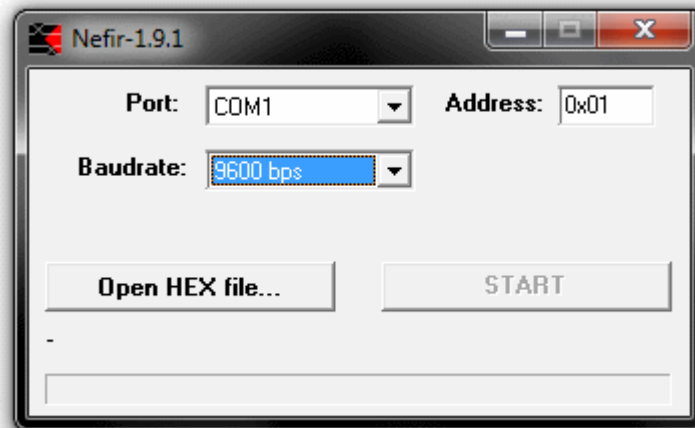

Drawing 9.1 Program window while reloading firmware