



*eLR100-UL-EB*

*Manual*

# eLR100-UL-EB

Powered by MS500

---

# CONTETNS

Contetns.....	2
1. Introduction.....	3
1.1. Features.....	3
1.2. Block Diagram .....	4
2. System Description.....	5
2.1. Part Description.....	5
2.2. Power .....	6
2.3. Reset.....	7
2.4. Boot.....	8
2.5. UART.....	9
2.6. Optional Part .....	11
3. Application Note.....	14
3.1. Firmware Update .....	14
Document Revision and Reference .....	16

# 1. INTRODUCTION

eLR100-UL-EB is Internet of Things (IoT) Products Development Kit well suited for the developers supporting LoRa Network.

eLR100-UL-00 or eLR100-US-00 LoRa Module designed by eWBM is embedded on this Kit.

## 1.1. FEATURES

- eLR100-US/HF Module include
  - eWBM ultra low power advanced security MCU MS500
    - ✓ Cortex M0
    - ✓ Hardware Security system.
  - Semtech SX1272 radio transceiver supporting LoRa
  - UART Communication Interface
    - ✓ AT-Command set support for LoRaWAN
- SMA connector

## 1.2. BLOCK DIAGRAM

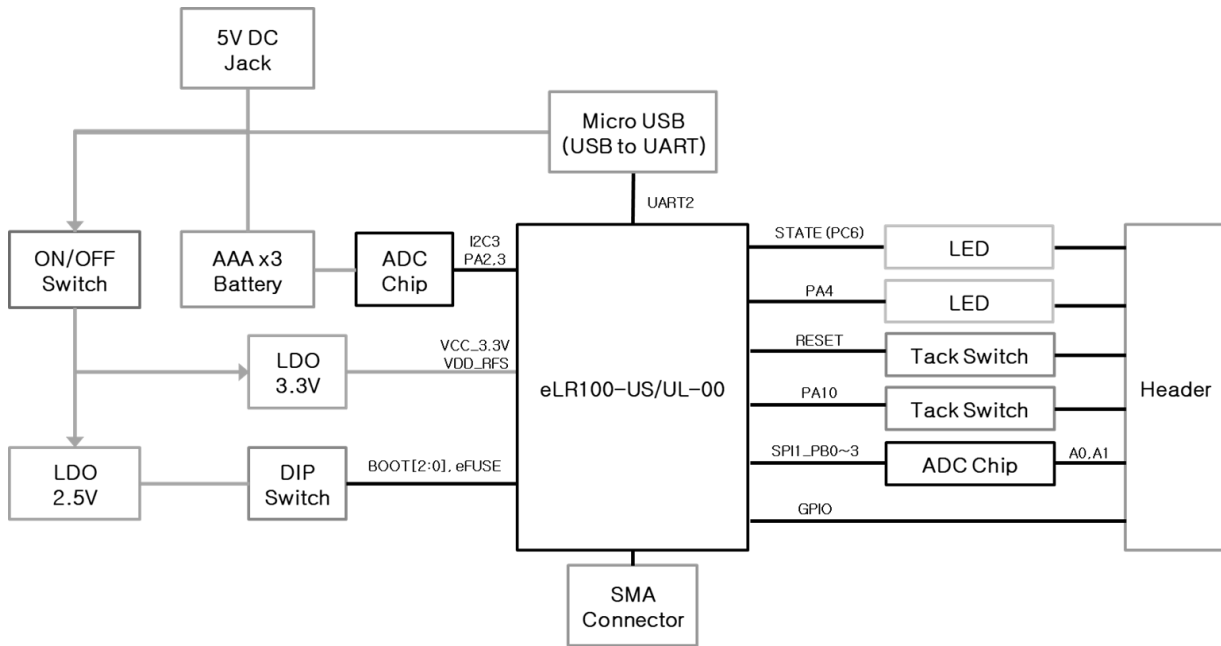

Figure 1 Hardware Block Diagram

## 2. SYSTEM DESCRIPTION

### 2.1. PART DESCRIPTION

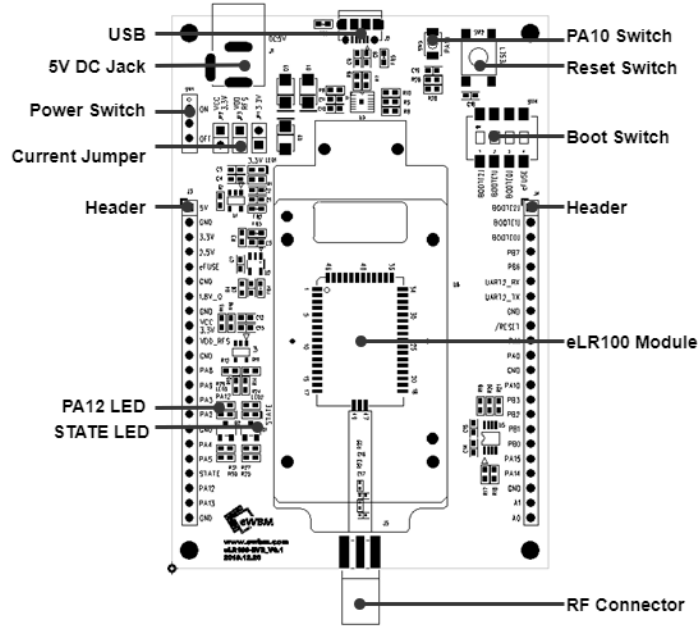

Figure 2 eLR100-UL-EB Parts

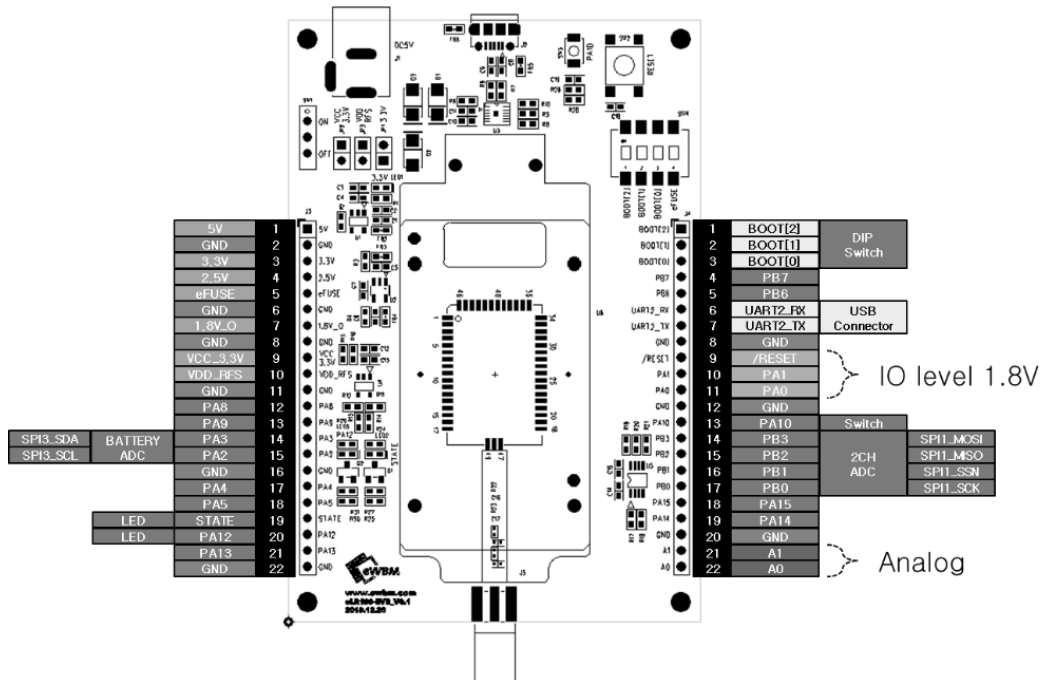

Figure 3 eLR100-EB Header J3,4 pinout diagram

## 2.2. POWER

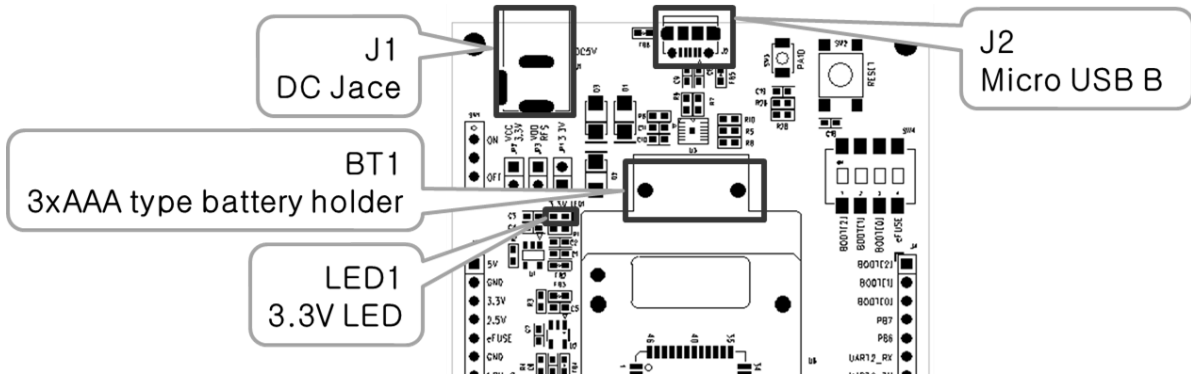

Figure 4 Input Power, Power LED

### 2.2.1. Input Power

There are three options for supplying the 5V DC to the board as following:

1. Battery (BT1)
2. DC Jack (J1)
3. USB Connector (J2)

Table 1. Input Power

Input	Battery	DC Jack	USB Connector
Reference	BT1	J1	J2
Connector	AAA 3EA Holder	DC 5V 2.0 pi	Micro USB B Type

### 2.2.2. Power LED (LED1)

Once the external 5V DC power supplied to the board is regulated down to 3.3V Power LED (LED2) turns on.

## 2.3.RESET

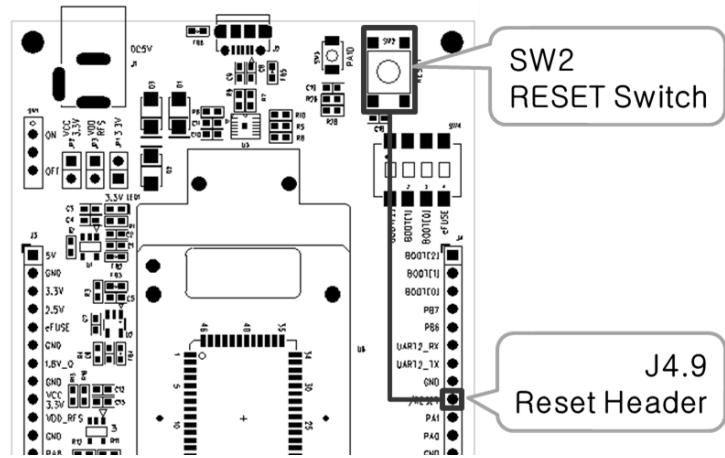

Figure 5 Reset Header, Switch

### 2.3.1. Reset Switch (SW2), Reset Header (J4.9)

- The voltage level of RESET is 1.8V.
- There is a 1.8V pull up circuitry inside the module.
- When a host board is controlled by the reset switch, the default attribute is set as INPUT. For resetting the device, the LOW value should be maintained for 1ms and then configure it as INPUT.

Example Code

```
pinMode(8 ,INPUT);
pinMode(8 ,OUTPUT);
digitalWrite(8, LOW);
delay(1);
pinMode(8 ,INPUT);
```

### 2.3.2. Software Reset (AT Command)

The device can be reset by using the AT+Command ‘AT+RESET’. Please refer to the AT+Command manual for more details.

## 2.4. BOOT

### 2.4.1. Boot Mode / eFuse

Boot Mode and eFuse setting can be done through Boot Mode/eFuse Setting Switch (SW4). Refer to Table 2 for BOOT mode setting.

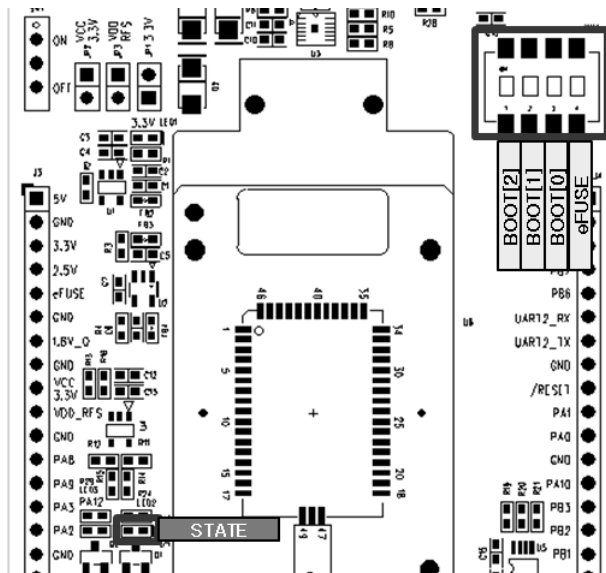

Figure 6 Boot Mode Setting

Table 2. Boot Mode Table

BOOT MODE	BOOT[2]	BOOT[1]	BOOT[0]	eFUSE
ROM BOOT (Default)	OFF 0	OFF 0	OFF 0	OFF 0
UART-Flash Update (Firmware Update)	OFF 0	ON 1	OFF 0	OFF 0
eFUSE Data Mode	OFF 0	OFF 0	ON 1	ON 1

### 2.4.2. STATE LED (LED 2)

When the LoRa Module is successfully booted, the LED2 turns on.



## 2.5. UART

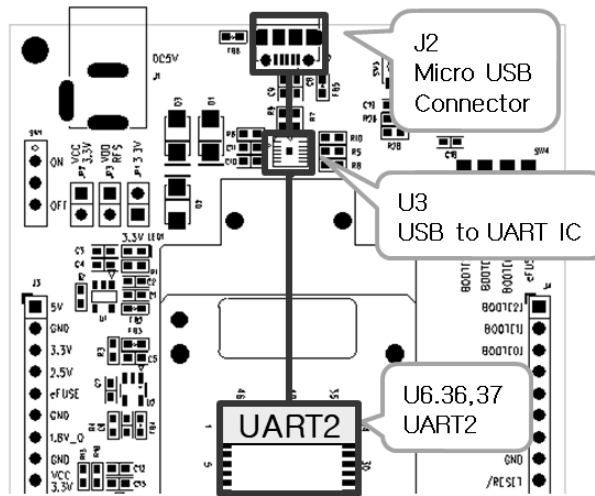

Figure 7 Arduino Type Header Description

### 2.5.1. UART 2

The UART2 port of eLR100-US/UL-00 module can be accessed via USB Connector(J2), through which firmware updates or AT+command control is supported.

#### AT Command Setting

- Boot Mode Setting
  - ROM Boot Mode (BOOT [2:0] = 3'b000)
- Serial Port Setup

Port Setup Information	
Baud Rate	115200
Data	8 bit
Parity	None
Stop	1 bit
Flow Control	None

### **Firmware Update Mode Setting**

- Boot Mode Setting
  - UART-Flash Update Mode (BOOT [2:0] = 3'b010)
- Serial Port Setup
  - Refer to Firmware Updater Setting

## 2.6. OPTIONAL PART

### 2.6.1. Battery Check

The battery level can be measured by using external AD Converter circuitry as shown in Figure 9.

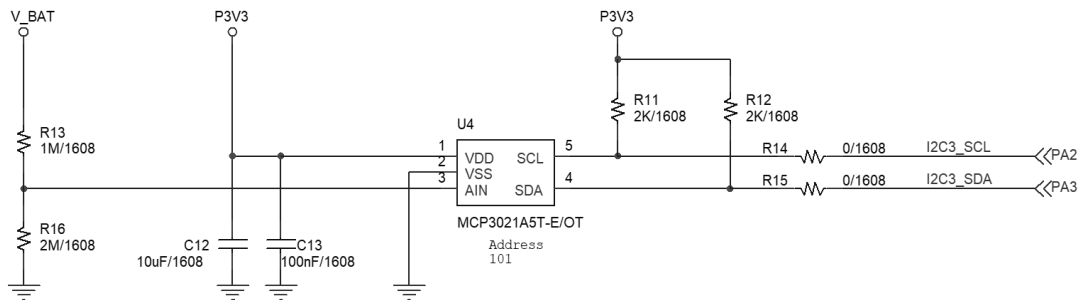

**Figure 8 Battery Supply Circuit**

- V\_BAT Max Voltage Input: 4.9V
- ADC Converter Chip: MCP3021A5T-E/OT
  - Interface: I2C3(PA2,3)
    - ✓ 400kHz Fast Mode
  - Resolution: 10-bit
  - Standby Current: 5 nA typical, 1  $\mu$ A maximum
  - Address: 101

### 2.6.2. ADC

Dual Channel (A0, A1) ADC can be utilized with SPI1 channel of the LoRa Module.

- Dual Channel ADC Converter Chip
  - Interface: SPI1(PB0,1,2,3)
  - ✓ 1MHz Less
  - Resolution: 10-bit
  - Standby Current:5 nA typical, 2  $\mu$ A maximum
- Analog Input Channel Locations
  - A0: J4.22
  - A1: J4.21

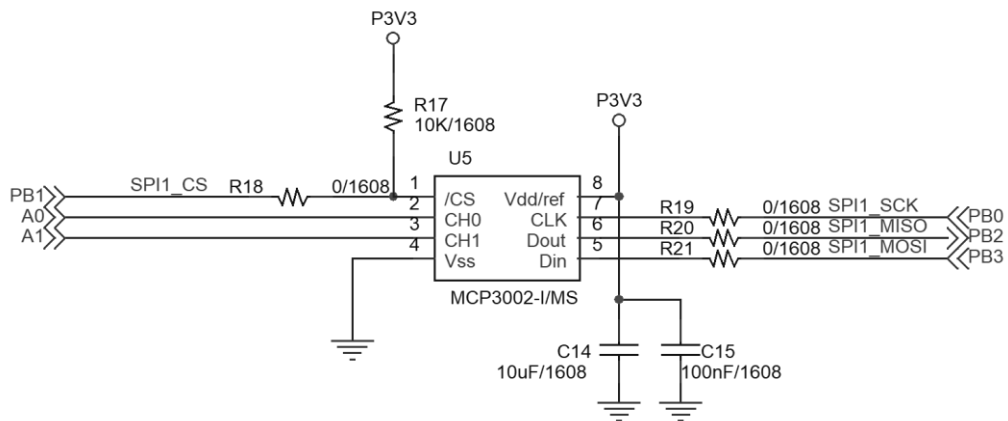

Figure 9 ADC Circuit

### 2.6.3. GPIO

Unused GPIO can be controlled by proper configuration on the LoRa Module. Use the “AT+GPIO” command to configure the GPIO to In/OUT, or readout the pin status. For more details, please refer to the AT+Command Manual.

#### **LED (LED3)**

The LED (LED3) can be controlled by using PA12 in the LoRa Module. The LED blinks when the PA12 is set to OUTPUT HIGH.

#### **Switch (SW3)**

The input status of PA10 can be controlled by SW3. The default value of PA10 is HIGH (3.3V). When the pin is pressed, the value becomes LOW (0V).

### 3. APPLICATION NOTE

#### 3.1. FIRMWARE UPDATE

##### 3.1.1. Board Setting

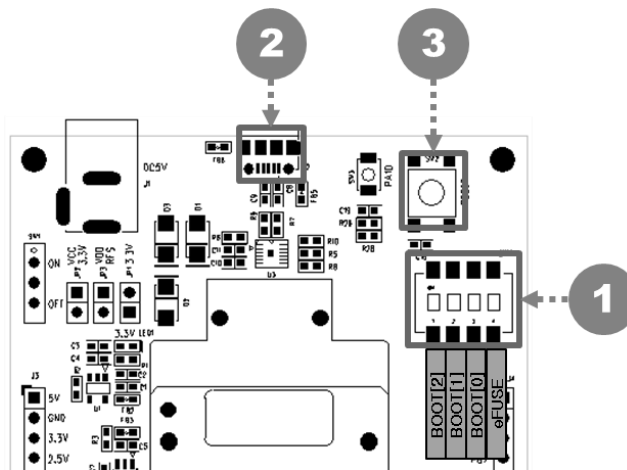

Figure 10 Firmware Update Board Setting

1. Set the Boot Mode to Firmware Upload Mode by using the Boot Mode Switch(SW4).

Table 3. Boot Mode Setting

Mode	Switch Setting	Description
Default Mode (ROM BOOT)	0000	The default Running Mode
Firmware Upload Mode (UART to Flash Boot)	0100	<ul style="list-style-type: none"> <li>- Firmware Upload Mode</li> <li>- Should be switched back to the default running mode after the Firmware update is completed.</li> </ul>

2. Make connection between Micro USB Connector(J2) of module and PC using Micro USB Cable.
3. Reset the module by pressing the Reset Switch (SW2).

### 3.1.2. Firmware Updater Setting & Upload

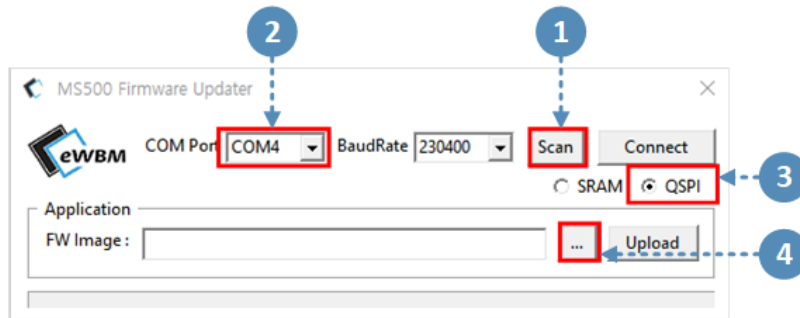

Figure 11 Firmware Setting 1

1. Click on Scan when eLR100-EVB is connected to PC.
2. Configure COM Port to the Port connected to eLR100-EVB
3. Select QSPI
4. Click “ ...” To select .img file to Upload.

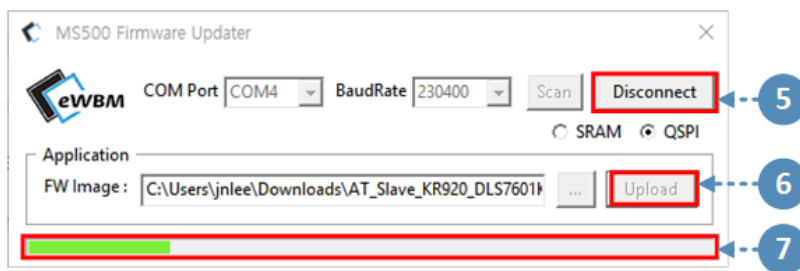

Figure 12 Firmware Setting 2

5. Click on Connect
6. Click on Upload
7. Check the Green Bar for the Upload Status. .

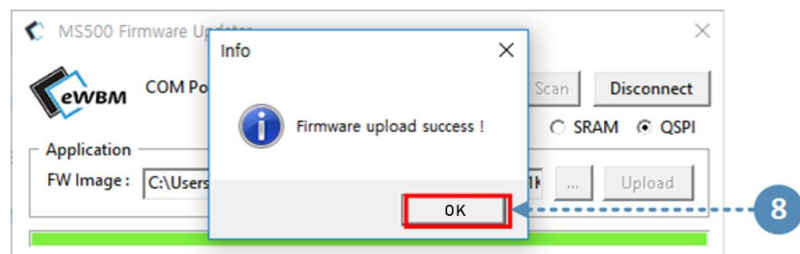

Figure 13 Firmware Setting 3

8. “Firmware Upload Success !” should be appeared when everything is successfully done.
- Board Configuration is set to default running mode after the Upload is completed.



# DOCUMENT REVISION AND REFERENCE

## Revision History

Revision	Date	Description
0.1	2019-03-05	1 <sup>st</sup> Release



# COPYRIGHT NOTICE

Copyright © 2019 eWBM Co., Ltd. All rights reserved.

This document is the copyrighted work of eWBM Co., Ltd. and is owned by eWBM Co., Ltd. It is provided as a reference for the sole purpose of MS500 microcontroller based system design.

No part of the software and documentation may be reproduced, transmitted, or translated, in any form or by any means, electronic, mechanical, manual, optical, or otherwise, without prior written permission of eWBM Co., Ltd.

## NO WARRANTY NOTICE

eWBM Co., Ltd. makes no warranty of any kind in regard to this material which is delivered to you as is, including, but not limited to, the implied warranties as to its accuracy or fitness for a specific purpose. Any use of this technical documentation or the information contained therein is at the risk of the user. eWBM Co., Ltd. shall not be liable for errors contained therein or for incidental consequential damages in connection with the furnishing, performance or use of the material.