



# LGE3M160120B

## Silicon Carbide Power MOSFET



### Features

- High voltage, low on resistance
- High speed, low parasitic capacitance
- High junction temperature
- Fast recovery diode

$V_{DS} = 1200\text{ V}$   
 $I_D@25^\circ\text{C} = 19\text{ A}$   
 $R_{DS(ON)} = 160\text{ m}\Omega$

### Benefits

- Higher System Efficiency
- Parallel Device Convenience without thermal runaway
- High Temperature Application
- Hard Switching & Higher Reliability
- Easy to drive

### Applications

- motor drive
- Photovoltaic inverter
- UPS power supply
- High voltage DC / DC converter
- Switching Mode Power Supply

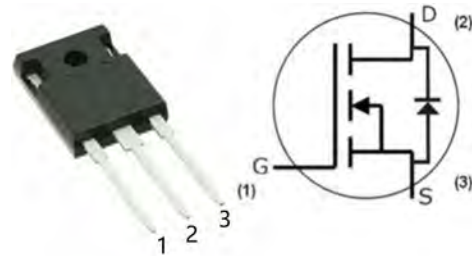

TO-247-3L

### Key performance parameters

Type	$V_{DS}$	$I_D$ $T_C=25^\circ\text{C}$	$R_{DS(ON)}$
LGE3M160120B	1200V	19A	160m $\Omega$



# LGE3M160120B

## Silicon Carbide Power MOSFET



### Maximum Ratings

$T_C=25^{\circ}\text{C}$ , unless otherwise specified

Parameter	Symbol	Value	Unit
Drain-source voltage $V_{GS} = 0\text{V}$ , $I_D = 100 \mu\text{A}$	$V_{DS}$	1200	V
Gate-source voltage Recommended maximum	$V_{GS}$	-5 to 20	V

### Maximum Ratings

$T_C=25^{\circ}\text{C}$ , unless otherwise specified

Parameter	Symbol	Value	Unit
Continuous drain current : $V_{GS} = 20\text{V}$ $T_C = 25^{\circ}\text{C}$ $T_C = 100^{\circ}\text{C}$	$I_D$	19 14	A
Pulsed drain current: Pulse width limited by SOA	$I_{DM}$	48	A
Power dissipation : $T_C = 25^{\circ}\text{C}$	$P_{TOT}$	134	W
Storage temperature range :	$T_{stg}$	-55 to +175	$^{\circ}\text{C}$
Operating and junction temperature:	$T_j$	-55 to +175	$^{\circ}\text{C}$
Soldre temperature: Wave soldering only allowed at leads, 1.6 mm from case for 10 s	$T_L$	260	$^{\circ}\text{C}$

### Thermal Resistance

Parameter	Symbol	Typ.	Unit
Thermal resistance to shell	$R_{thJC}$	1.122	$^{\circ}\text{C}/\text{W}$

Caution: This device is sensitive to electrostatic discharge .Users should follow ESD handling procedures.



# LGE3M160120B

## Silicon Carbide Power MOSFET



### Electrical Characteristic

$T_c = 25^\circ\text{C}$ , unless otherwise specified

Parameter	Symbol	Value			Unit	Test Condition
		Min.	Typ.	Max.		
Zero gate voltage drain current	$I_{DSS}$		5	100	$\mu\text{A}$	$V_{DS} = 1200\text{V}$ $V_{GS} = 0\text{V}$
Gate leakage current	$I_{GSS}$		1	$\pm 100$	nA	$V_{DS} = 0\text{V}$ $V_{GS} = -5\sim 20\text{V}$
Gate threshold voltage	$V_{TH}$		2.9 1.9		V	$V_{GS} = V_{DS}$ $I_D = 1.9\text{mA}$ $T_C = 175^\circ\text{C}$
Drain-source on-state resistance	$R_{ON}$		160 285	195	$\text{m}\Omega$	$V_{GS} = 20\text{V}$ $I_D = 10\text{A}$ $T_J = 25^\circ\text{C}$ $T_J = 175^\circ\text{C}$
Input capacitance	$C_{iss}$		895		pF	$V_{DS} = 800\text{V}$ $V_{GS} = 0\text{V}$ $f = 1\text{MHz}$ $V_{AC} = 25\text{mV}$
Output capacitance	$C_{oss}$		43			
Reverse transfer capacitance	$C_{rss}$		2			
The output capacitor stores energy	$E_{oss}$		4.2		$\mu\text{J}$	
Total gate charge	$Q_g$		43		nC	$V_{DS} = 800\text{V}$ $I_D = 10\text{A}$ $V_{GS} = -5\text{ to }20\text{V}$
Gate to source charge	$Q_{gs}$		9			
Gate to drain charge	$Q_{gd}$		19			
Gate input resistance	$R_g$		8.5		$\Omega$	$f = 1\text{MHz}$
Turn-on switching energy	$E_{ON}$		204		$\mu\text{J}$	$V_{DS} = 800\text{V}$ , $I_D = 10\text{A}$ , $V_{GS} = -2\text{ to }20\text{V}$ , $R_{G(ext)} = 3.3\Omega$ , $L = 450\mu\text{H}$
Turn-off switching energy	$E_{OFF}$		34.4		$\mu\text{J}$	
Turn-on delay time	$t_{d(on)}$		15.2		ns	
Rise time	$t_r$		14.4			
Turn-off delay time	$t_{d(off)}$		11.3			
Fall time	$t_f$		13.1			

Caution: This device is sensitive to electrostatic discharge .Users should follow ESD handling procedures.



# LGE3M160120B

## Silicon Carbide Power MOSFET



### Reverse Diode Characteristics

$T_C = 25^\circ\text{C}$ , unless otherwise specified

Parameter	Symbol	Value			Unit	Test Condition
		Min.	Typ.	Max.		
Diode forward voltage	$V_{SD}$		4.1 3.7		V	$I_{SD} = 5\text{A}$ $V_{GS} = 0\text{V}$ $T_J = 175^\circ\text{C}$
Reverse recovery time	$t_{rr}$		33.2		ns	$V_{GS} = -2\text{V}/+20\text{V}$ , $I_{SD} = 10\text{A}$ , $V_R = 800\text{V}$ , $di/dt = 1000\text{A}/\mu\text{s}$ , $R_{G(\text{ext})} = 13\Omega$
Reverse recovery charge	$Q_{rr}$		101.5		nC	
Reverse recovery peak current	$I_{RRM}$		5.6		A	

Caution: This device is sensitive to electrostatic discharge .Users should follow ESD handing procedures.



### Characteristics Curves



图. 1 输出曲线 @  $T_j = -55^\circ\text{C}$



图. 2 输出曲线 @  $T_j = 25^\circ\text{C}$

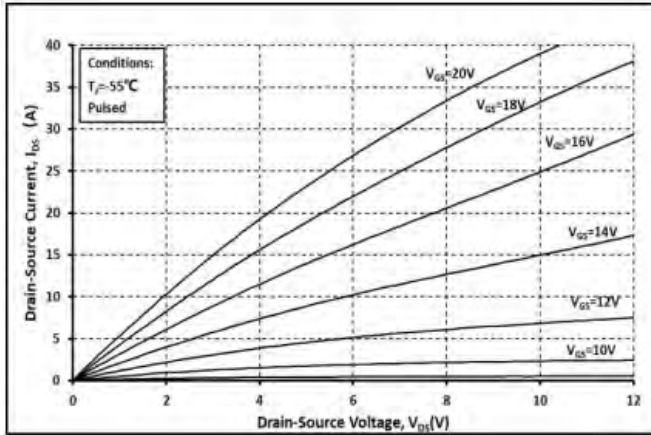

图. 3 输出曲线 @  $T_j = 175^\circ\text{C}$

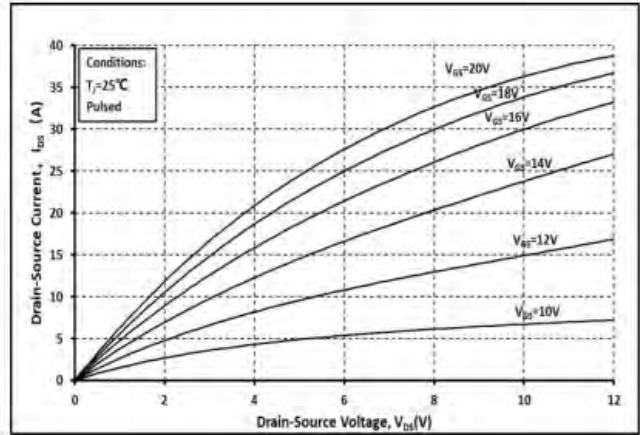

图. 4  $R_{on}$  和温度关系曲线

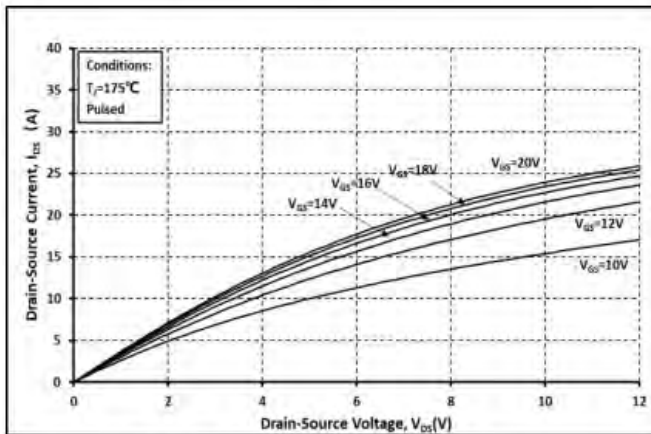

图. 5 归一化的  $R_{on}$  和温度关系曲线

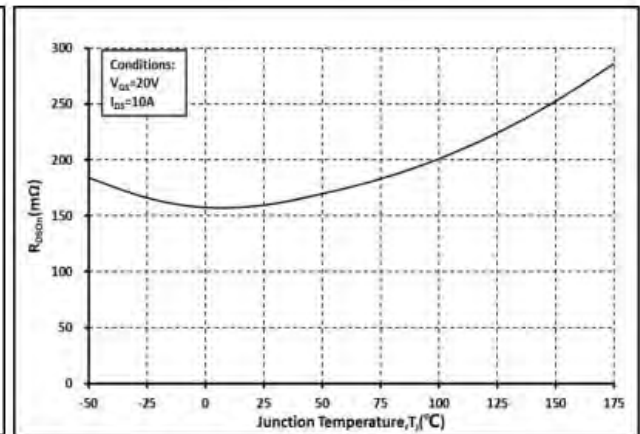

图. 6 各温度下的  $R_{on}$  和  $I_{ds}$  关系曲线

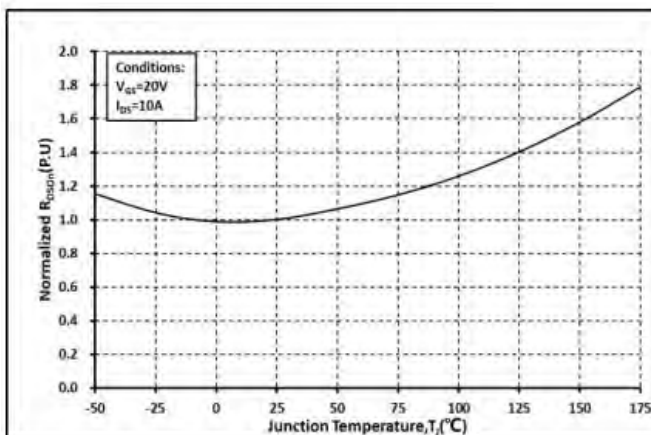

图.7 各  $V_{GS}$  下的  $R_{on}$  和温度关系曲线

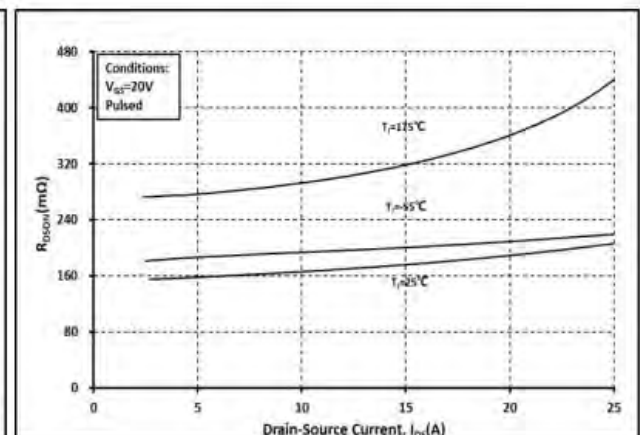

图.8 各温度下的传输特性曲线

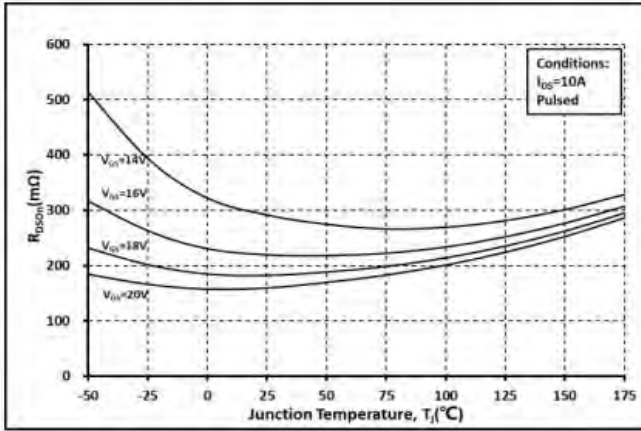

图.9 阈值电压随温度变化曲线

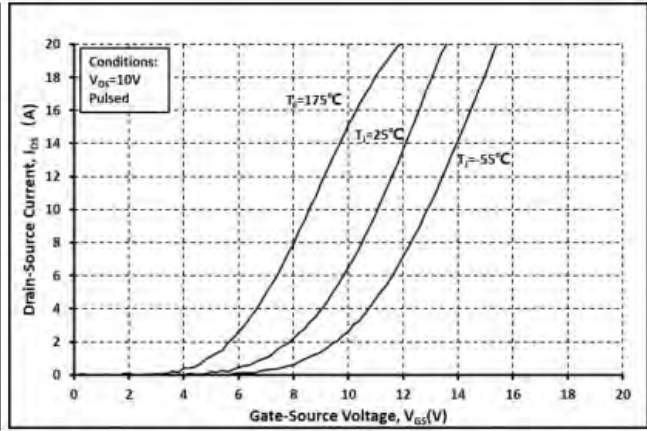

图.10 体二极管导通曲线 @  $T_j = -55^\circ\text{C}$

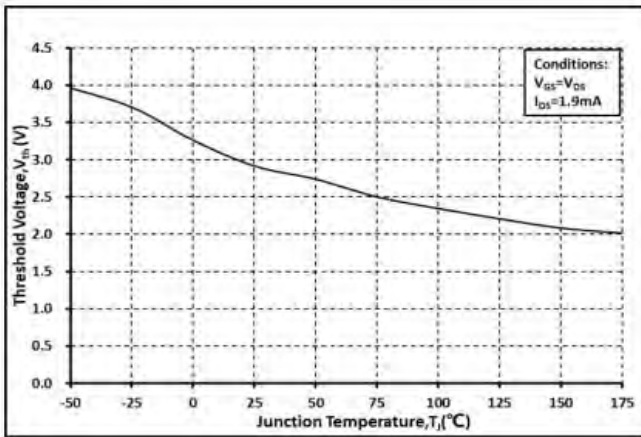

图.11 体二极管导通曲线 @  $T_j = 25^\circ\text{C}$

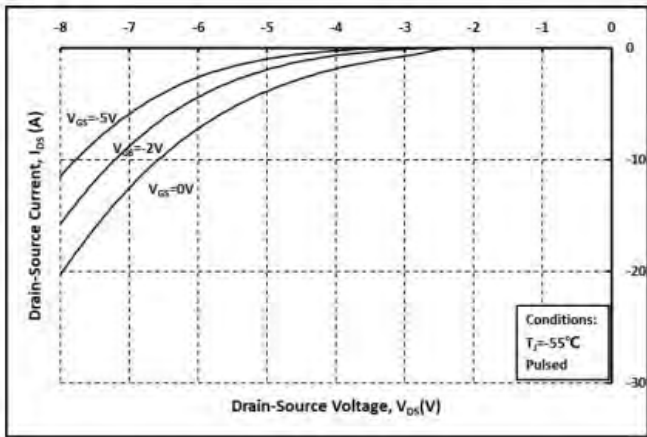

图.12 体二极管导通曲线 @  $T_j = 175^\circ\text{C}$

Caution: This device is sensitive to electrostatic discharge .Users should follow ESD handing procedures.

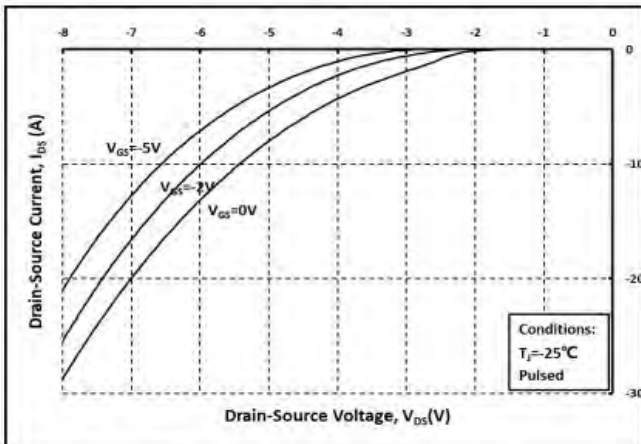

图. 13 第三象限曲线 @  $T_j = -55^\circ\text{C}$

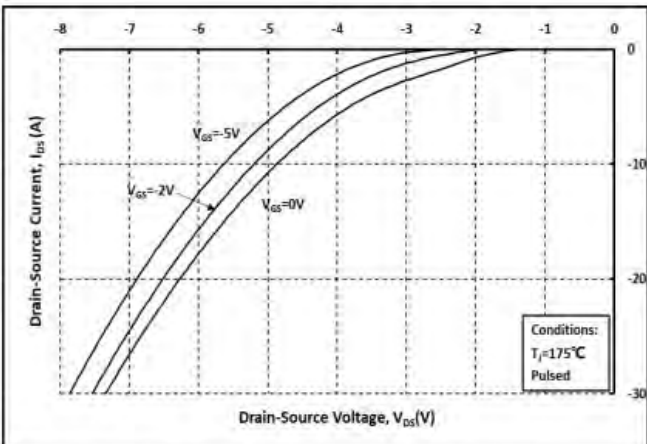

图. 14 第三象限曲线 @  $T_j = 25^\circ\text{C}$

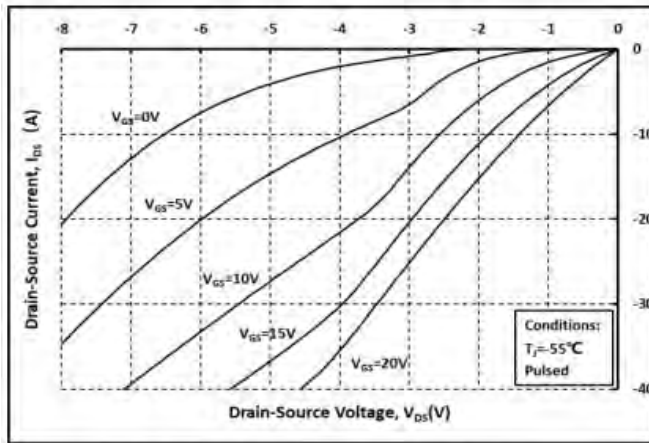

图. 15 第三象限曲线 @  $T_j = 175^\circ\text{C}$

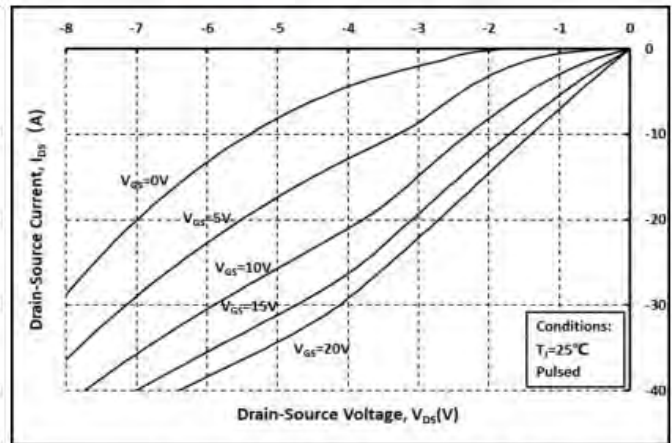

图. 16 各电容和  $V_{DS}$  关系曲线

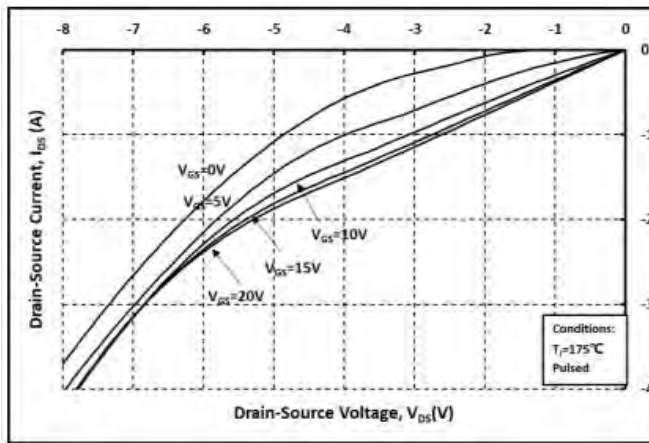

图. 17 输出电容存储能量曲线 c

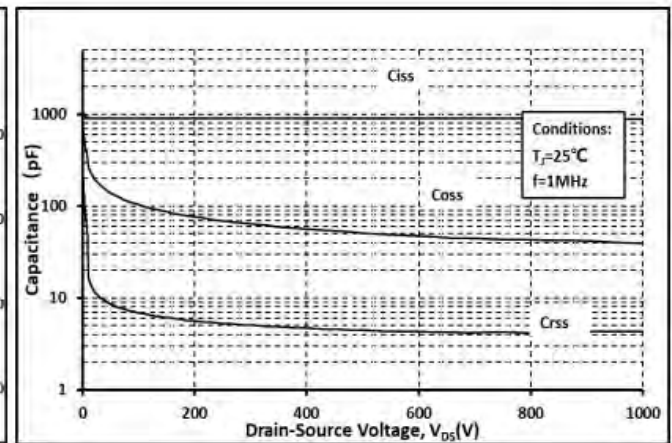

图. 18 栅电荷特征曲线 c

Caution: This device is sensitive to electrostatic discharge .Users should follow ESD handling procedures.

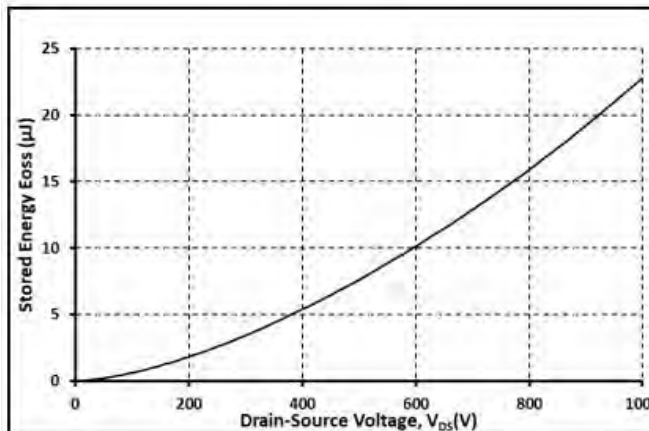

图. 19 开关能量和栅极电阻  $R_{G(ext)}$  关系曲线

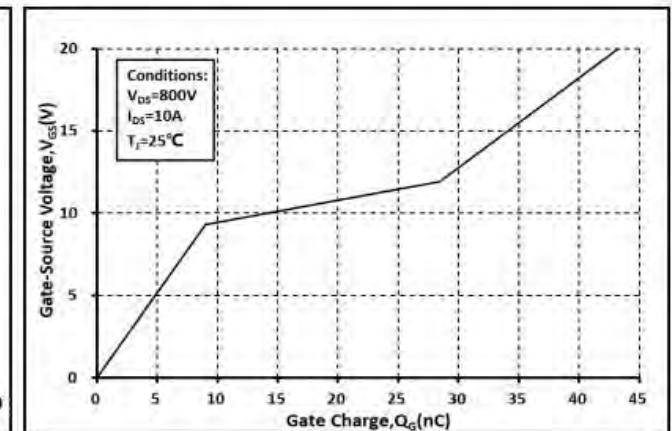

图. 20 开关时间和栅极电阻  $R_{G(ext)}$  关系曲线

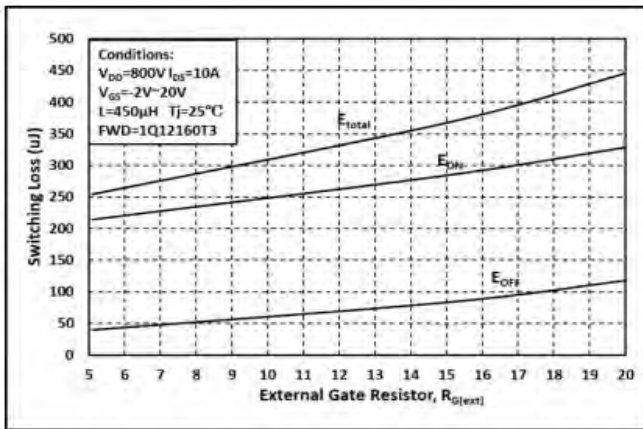

图. 21 漏端电流和温度关系曲线

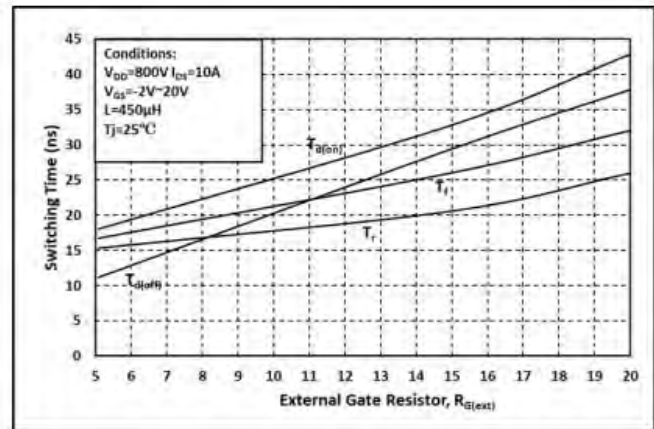

图. 22 最大功耗降额和温度关系曲线

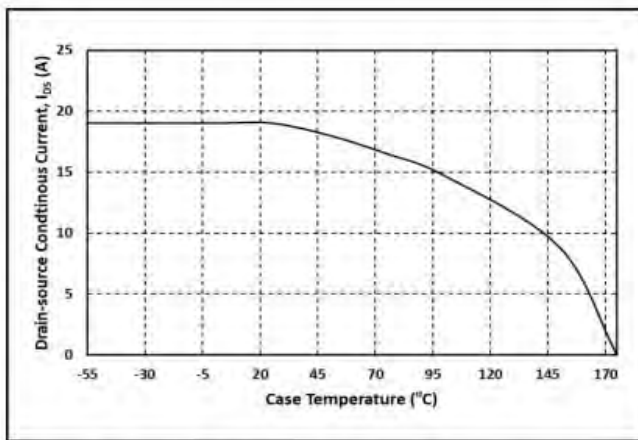

图. 23 热阻曲线

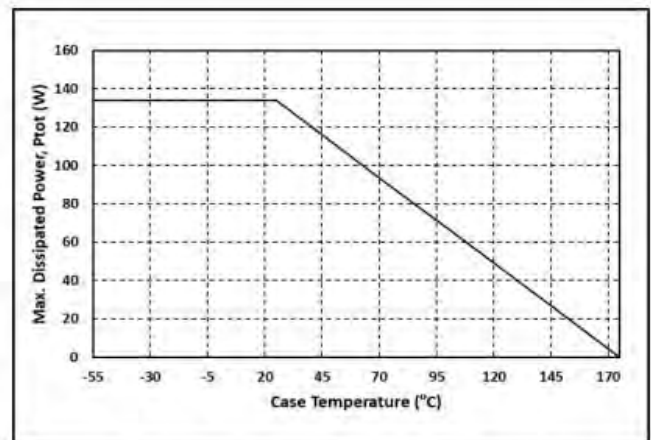

图. 24 安全工作区示意图

Caution: This device is sensitive to electrostatic discharge .Users should follow ESD handling procedures.

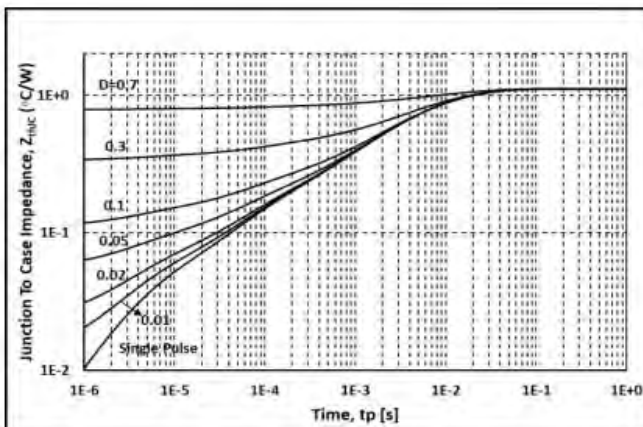

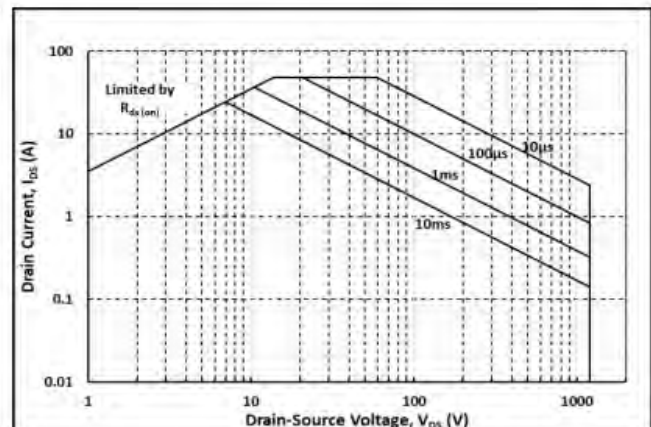
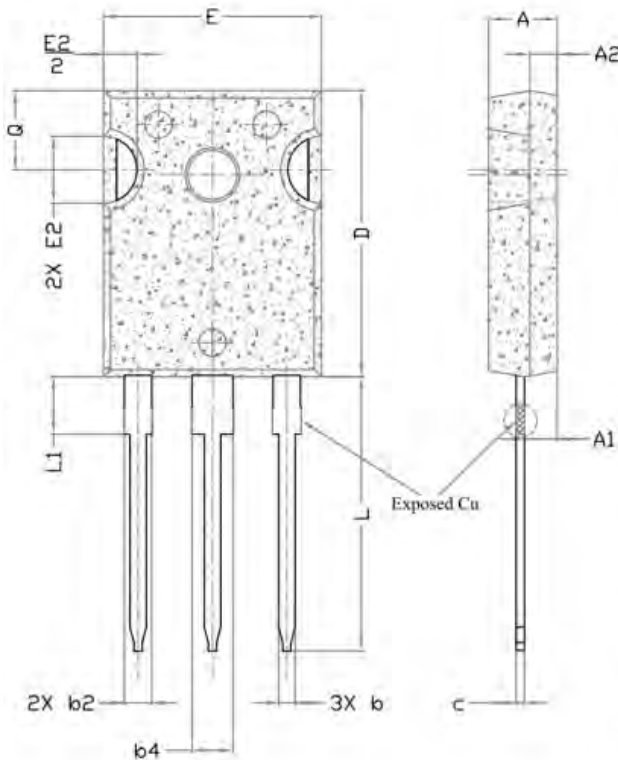

SYMBOL	DIMENSIONS			NOTES
	MIN.	NOM.	MAX.	
A	4.83	5.02	5.21	
A1	2.29	2.41	2.55	
A2	1.50	2.00	2.49	
b	1.12	1.20	1.33	
b1	1.12	1.20	1.28	
b2	1.91	2.00	2.39	6
b3	1.91	2.00	2.34	
b4	2.87	3.00	3.22	6, 8
b5	2.87	3.00	3.18	
c	0.55	0.60	0.69	6
c1	0.55	0.60	0.65	
D	20.80	20.95	21.10	4
D1	16.25	16.55	17.65	5
D2	0.51	1.19	1.35	
E	15.75	15.94	16.13	4
E1	13.46	14.02	14.16	5
E2	4.32	4.91	5.49	3
e	5.44BSC			
L	19.81	20.07	20.32	
L1	4.10	4.19	4.40	6
∅P	3.56	3.61	3.65	7
∅P1	7.19REF.			
Q	5.39	5.79	6.20	
S	6.04	6.17	6.30	

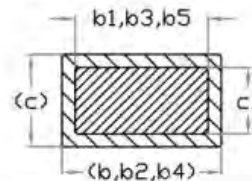
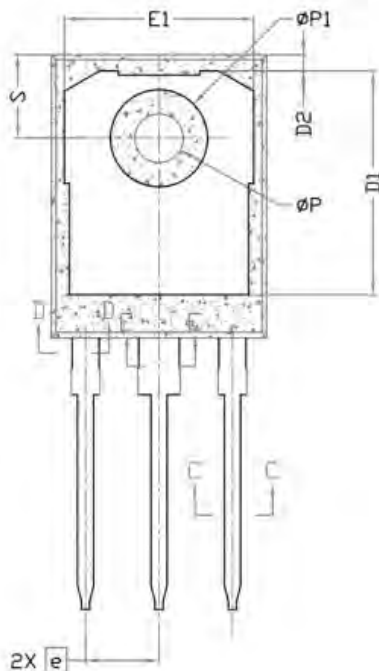

Section C-C, D-D, E-E

**说明:**

1. 封装标准参考: : JEDEC TO247, Variation AD
2. 以上单位为: 毫米
3. 需要开槽, 槽口可为圆形
4. 尺寸 D 和 E 不包括模具溢料

Caution: This device is sensitive to electrostatic discharge .Users should follow ESD handling procedures.