

1

2

3

4

5

6

7

FOR
客户名称APPROVED
客户确认签字ATTN
销售负责人

A

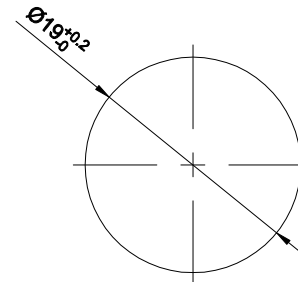
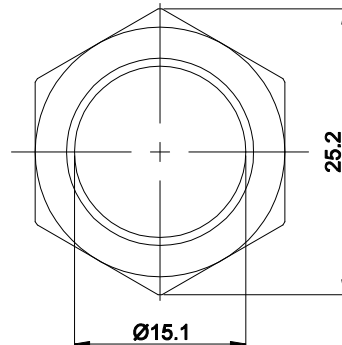
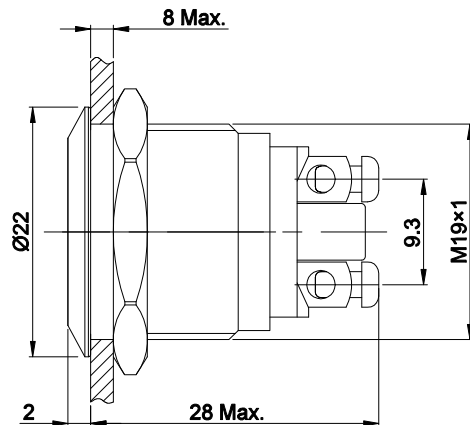

PANEL CUTOUT

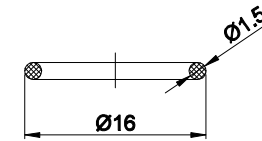

SEAL RING

B

B

C

C

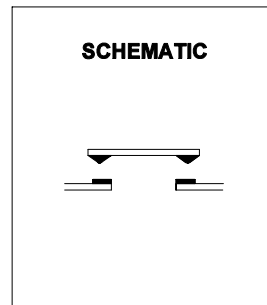

SCHEMATIC

PART NUMBER:GQ19F-10/◎

"◎"	CRUST MATERIAL
N	NICKEL PLATED BRASS
S	STAINLESS STEEL
A	AL ALLOY(BLACK)

SPECIFICATIONS:

- SWITCH RATING: $U_i:250V, I_{th}:5A$.
- SWITCH OPERATION: MOMENTARY.
- MECHANICAL LIFE: $\geq 1,000,000$ cycles.
- ELECTRICAL LIFE: $\geq 50,000$ cycles.
- INITIAL CONTACT RESISTANCE: $\leq 50m\Omega$.
- INSULATION RESISTANCE: $\geq 100M\Omega(500VDC)$.
- DIELECTRIC STRENGTH: 1,500V, RMS 50HZ, 1min.
- OPERATING TEMPERATURE: $-25^{\circ}C \sim +55^{\circ}C$ (NO FREEZING, KEEP THE AIR FLOWING AROUND PUSHBUTTON).
- OPERATING FORCE: ABOUT 4N.
- OPERATING TRAVEL: ABOUT 1.8mm.
- TORQUE: 0.6Nm Max.APPLIED TO NUT.
- FRONT PANEL PROTECTION DEGREE: IP65,IK09.
- TERMINAL TYPE: SCREW TERMINAL.
- GENERAL TOLERANCE:0-18mm ± 0.25 , 18-80mm ± 0.52 .

MATERIALS:

- CONTACT: SILVER ALLOY.
- BUTTON: STAINLESS STEEL.
- BODY: STAINLESS STEEL.
- BASE: PBT.

D

D

E

E

1

2

3

4

5

6

7

BRAND 品牌

红波按钮制造有限公司

ONPOW 欧宝龙®

ONPOW PUSH BUTTON MANUFACTURE CO.,LTD.

TITLE 名称	GQ SERIES ANTI-VANDAL PUSH BUTTON		UNIT 单位	mm	
DWG NO. 图号	GQ19F-10	SCALE 比例	1.5 : 1	SIZE 图纸	A4
FILE NAME 档案名称	GQ19F.DWG	DRAWN 制图	YDY 2023/10/25	SHEET 张	1/1
		REV. 更改			1