



AX-EL300W - Programmable DC Electronic Load - Operation Manual

1.

Use of Operation Manual

Please read through and understand this Operation Manual before operating the product. After reading, always keep the manual nearby so that you may refer to it as needed. When moving the product to another location, be sure to bring the manual as well.

Calibration notification

We notify that the instruments included in this manual are in compliance with the features and specifications as stated in this manual. Before shipment, the instrument has been calibrated in factory. The calibration procedures and standards are compliant to the national regulations and standards for electronic calibration.

Warranty

We guarantee that the instrument has been passed strict quality check. We warrant our instrument's mainframe and accessories in materials within the warranty period of one year. We guarantee the free spare parts for products which are approved defective in this period. To get repair service, please contact with your nearest sales and service office. We do not provide any other warranty items except the one being provided by this summary and the warranty statement. The warranty items include but not being subjected to the hinted guarantee items related to tradable characteristics and any particular purpose. We will not take any responsibility in cases regarding to indirect, particular and ensuing damage, such as modifications to the circuit and functions by the users, repairing or component replacement by the users, or damage during transportation.

For product improvement, the specifications are subject to change without prior notice.

2. General Introduction

2.0.

This Series programmable electronic load, as a new generation product, is designed with high performance. It provides you powerful test function, user-friendly HMI, as well as RS232 interface to support SCPI and Labview. This Series is widely used in aerospace, shipbuilding, automotive electronics, solar cell, and fuel cell etc. scientific research and production field.





All “electronic load” and “load” appear in this manual refer to this Series Electronic Load if there is no special explanation.

2.1. Function Features

- 4 basic functions: CC, CV, CR and CP; 9 basic test modes: CCL, CCH, CVL, CVH, CRL, CRM, CRH, CPV, CPC;
- The 24 bit A/D and 16 bit D/A converters incorporated, provide this equipment with greatly enhanced setting and measurement resolution. 40kHz D/A conversion rate fully improves high-speed performance;
- Perfect protection assures high reliability in the most complicated of test environments;
- Innovative design of CPV and CPC modes effectively improves the practicability of CP mode;
- Circuit improvement greatly enhances the dynamic response of CR mode and widens the application scope of that mode;
- High-speed transient operation with separate high/low level time and rising/falling time control, maximum test frequency 2kHz;
- Powerful sequential test function; with a minimum step time of 10us; and a maximum step time of 10000s. Cyclic numbers can be adjusted freely and a sequence can be chained to another sequence to achieve even more complex test procedures;
- The input binding posts with their innovative design are especially suitable for large current testing;
- Provides short-circuit test, battery discharge test and other auxiliary functions;
- A high-efficiency, intelligent cooling system can effectively reduce system temperature and enhance power density;
- Automatic ON/OFF function simplifies test operation;
- Knobs and digital keypad makes the operation more convenient;
- Save/recall function can save multiple groups of general settings;
- Supports SCPI (Standard Commands for Programmable Instrumentation) and Labview, and provides necessary PC software;

2.2. Production Models

Item /// Model /// Rated Input - Power /// Rated Input - Voltage /// Rated Input - Current /// Weight [kg]
/// Dimension (W*H*D)
1 /// B /// 300W /// 0~150V /// 1mA~30A /// 6,7 /// 215x89x412mm



2.3. Front Panel

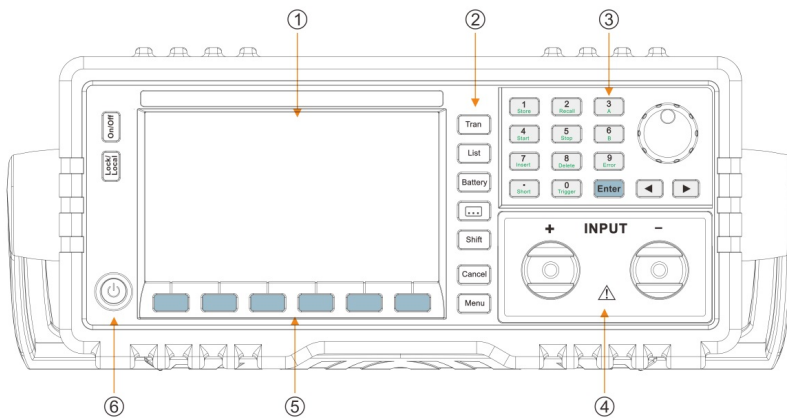

Fig. 2-1

- 1.LCD display
- 2.Function buttons
- 3.Parameters input
- 4.Input binding posts
- 5.Menu keys
- 6.Power switch

2.4. Message of LCD Display

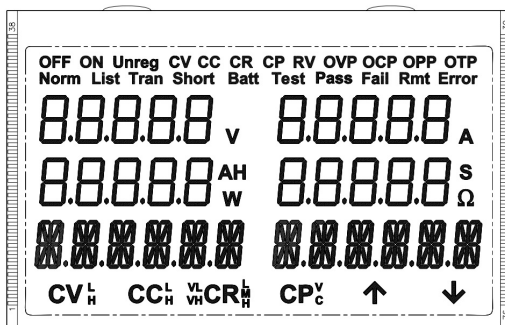

Fig. 2-2



2.5. Rear Panel

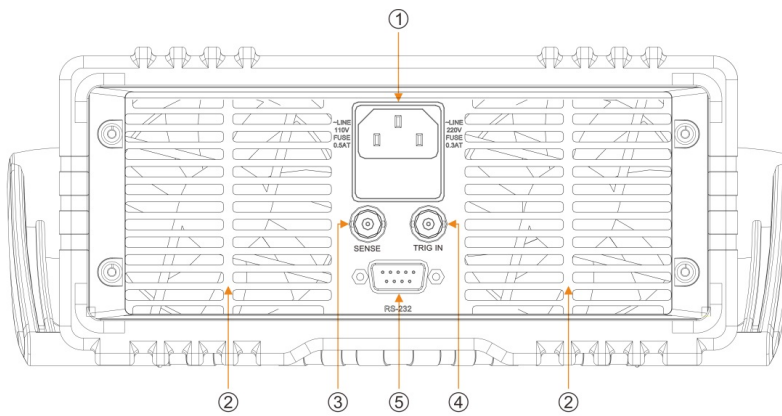

Fig. 2-3

- 1.Power cord / fuse socket
- 2.Cooling fan
- 3.Remote sense terminal
- 4.External trigger input terminal
- 5.RS232 interface

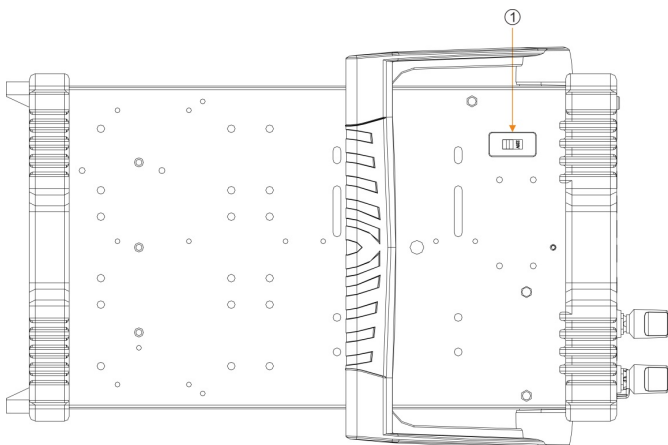
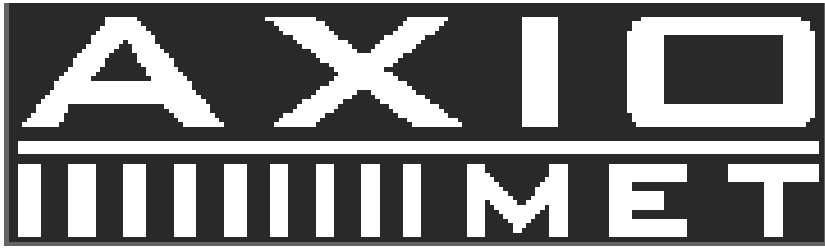

Fig. 2-4





1. AC110/220V power selection switch

2.6. Keypad Function

There are three groups of keypads on the front panel: the Function Keys, the Entry Keys, which composite with secondary functions, and the Direction Keys. The first functions of the Entry Keys are printed in black. The secondary functions of the Entry Keys are printed in green. To use the secondary function, please press “Shift” key first, then press the relevant key.

Key name /// Main function /// Secondary key name /// Secondary function

0 /// Input digit 0 /// Trigger /// Trigger key
1 /// Input digit 1 /// Store /// Store key
2 /// Input digit 2 /// Recall /// Recall key
3 /// Input digit 3 /// A /// Point A setting
4 /// Input digit 4 /// Start /// Sequence (list) start key
5 /// Input digit 5 /// Stop /// Sequence (list) stop key
6 /// Input digit 6 /// B /// Point B setting
7 /// Input digit 7 /// Insert /// Insert key
8 /// Input digit 8 /// Delete /// Delete key
9 /// Input digit 9 /// Error /// Error code display key
/// Input decimal point /// Short /// Short circuit key
Enter /// Confirm key ///
◀ /// Left key ///
▶ /// Right key ///
Tran /// Transient operation menu ///
List /// Sequence (list) operation key ///
Battery /// Battery discharge operation key ///
... /// Set up auxiliary function, auto test ///
Shift /// Switch key for secondary function ///
Cancel /// Clear or exit /// Prot Clear /// Clear protection
Menu /// Main menu
On/Off /// Input on/off
Lock/Local /// Short-press for lock, long-press for unlock
I-set /// CC mode selection, the input current value setting
V-set /// CV mode selection, the input voltage value setting
P-set /// CP mode selection, the input power value setting
R-set /// CR mode selection, the input resistance value setting
↑ /// Page up
↓ /// Page down





2.7. Menus

2.7.1. Main Menu

Press “Menu” key to enter into main menu and the LCD displays the selectable menus. Rotate knob to select menu. Press “Enter” key to enter into the function option on the cursor. Use “↑” key or “↓” key to turn over the LCD screen. At this time, press “↓” key to enter into the next level submenu. Press “Cancel” key to exit the menu setting.

System Set

- /// CC SET /// Set CC mode range
- /// CV SET /// Set CV mode range
- /// CR SET /// Set CR mode range
- /// CP SET /// Set CP mode range
- /// VON LAtch /// Von volgate latch
- /// VON POint /// Set Von voltage point
- /// VOFF Point /// Set Voff voltage point
- /// CV CURr limit /// Current limit in CV mode
- /// CURR Rise rate /// Current rise rate in CC mode
- /// CURR Fall rate /// Current fall rate in CC mode
- /// SHORT /// Short circuit mode

Config

- /// LOAD Default /// Restore default
- /// INPUT recall /// Set the power-on input status as last power-off status
- /// POWER on recall /// Set the power-on relative parameters as last power-off settings
- /// KNOB /// Enable knob function
- /// KEY SOund /// Enable key sound
- /// BAUD Rate /// Baud rate setting
- /// PARITY check /// Parity check setting
- /// DATA Bit /// Data bit
- /// STOP bit /// Stop data bits
- /// ADDRESs /// Instrument’s ID or address
- /// SAVE /// Store parameters
- /// RECALL /// Recall parameters
- /// ERROR /// Error message

Protection

- /// OCP STate /// Overcurrent protection On/Off
- /// OCP LElvel /// Current pretection limit
- /// OCP DELay /// Delay time to turn off the load in OCP
- /// OVP LElvel /// Voltage pretection limit
- /// OPP LElvel /// Power pretection limit
- /// OPP DELay /// Delay time to turn off the load in OPP





Trigger Set

/// FUNCTIon /// Trigger function selection
/// SOURCE /// Trigger source setting
/// CURRENTt /// Trigger current
/// VOLTAGe /// Trigger voltage
/// RESISTance /// Trigger resistance
/// POWER /// Trigger power

List

/// STATE /// Set sequence (list) test status
/// NO. /// Select sequence (list) number
/// MEMO /// Sequence memo
/// DATA: <New/Edit> /// Create a new or edit an existing sequence
/// COUNT /// Cycle times
/// CHAIN /// Sequence number to be chained with (0-7, off)

List data

/// NO. /// Data number
/// MODE /// Mode Time
/// LEVEL /// Setting value
/// DELAY /// Time

Battery

/// STATE /// Battery discharge operation key
/// MIN Voltage /// Termination voltage value
/// IOFF Piont /// Termination current value
/// DISCUR /// Discharge current value

Transient

/// STATE /// Transient operation status
/// MODE /// Transient operation mode
/// LEVELL /// Transient low level
/// LEVELH /// Transient high level
/// TIME L /// Time for transient low level
/// TIME H /// Time for transient high level
/// TIME R /// Time for transient rising edge
/// TIME F /// Time for transient falling edge

Auto test

/// STATE /// Auto test state on/off
/// END SStep /// End step (0-14)
/// STEP /// Step selection (0-14)
/// MODE /// Mode setting
/// LEVEL /// Setting value





/// MIN /// Parameter minimum value
/// MAX /// Parameter maximum value
/// DELAY /// Test time

△Note:

- The parameters of Config, Protection, Trigger Set and Auto Test in main menu will be saved automatically after been modified. The parameter saved in location 0 will be recalled automatically every time when the load is turned on.
- The capital letters of the menu will be shown on the LCD. The numbers of shown characters should not exceed 6.

2.7.2. Mode and Parameter Setting Menu

The electronic load can be excuted in the following modes.

- 1: Constant Current mode (CC)
- 2: Constant Voltage mode (CV)
- 3: Constant Resistance mode (CR)
- 4: Constant Power mode (CP)

In the basic mode, press corresponding key to enter into mode and parameter setting menu, which is shown as below:

Key name /// Function and parameter /// Description

I-SET /// SCCL 01.000A /// Constant current mode: immediate current level

V-SET /// SCVL 80.00V /// Constant voltage mode: immediate voltage level

R-SET /// SVHCRL 02.000R /// Constant resistance mode: immediate resistance level

P-SET /// SCPV 10.000W /// Constant power mode: immediate power level

2.7.3. Transient Operation Menu

In the basic mode, turn off the input, press “Tran” key in desired mode to enable its transient operation and enter into parameters setting menu.

Function /// Description

STATE /// Transient operation status and enable the function

MODE /// Transient operation mode; Continuous: 0 COUNT; Pulsed: 1 PULSE; Toggled: 2 TOGGLE

LEVELL /// Transient low level

LEVELH /// Transient high level

TIME L /// Time for transient low level (0-99999ms), unit is ms

TIME H /// Time for transient high level (0-99999ms), unit is ms

TIME R /// Time for transient rising edge (0.25-99999ms) , unit is ms

TIME F /// Time for transient falling edge (0.25-99999ms) , unit is ms

△ Note:

Transient operation may be used in CC, CV, and CR modes.





2.7.4. Sequence (List) Operation Menu

Press “List” key to enter into the list operation menu.

Function /// Description

STATE /// Enable the function

NO. /// Select sequence (list) number 0-7

MEMO /// Sequence memo (10 characters)

DATA: <New/Edit> /// Create a new or edit an existing sequence

COUNT /// Cycle times (1-65535), (Number 0 represents infinite loop)

CHANI: Off /// Sequence number to be chained with (0-7 off)

Press “↑” and “↓” keys in sequence (list) operation menu to select “Data: <New/Edit>”, and select “New” and “edit” keys with the knob. Then press “Enter” key to enter into sequence data editing status, which is shown as below:

Function /// Description

NO. /// Data number (0-49)

MODE /// Mode

LEVEL /// Setting value

DELAY /// Time, unit is s

Press “Cancel” key to store the data and exit.

2.8. Display Messages

1) CC Mode:

The LCD shows actual voltage, current, power and resistance levels. The second line shows current set level and CC mode.

2) CV Mode:

The LCD shows actual voltage, current, power and resistance levels. The second line shows voltage set level and CV mode.

3) CR Mode:

The LCD shows actual voltage, current, power and resistance levels. The second line shows resistance set level and CR mode (CRL indicates constant resistance low range; CRM indicates constant resistance medium range; CRH indicates constant resistance high range; VH indicates voltage high range; and VL indicates voltage low range).

4) CP Mode:

The LCD shows actual voltage, current, power and resistance levels. The second line shows power set level, CP mode (CPC indicates constant power-current source mode; CPV indicates constant power-voltage source mode).

5) Transient Operation:

The LCD shows actual voltage, current, power and resistance levels.





6) Sequence (List) Operation:

The LCD shows actual voltage, current, power and time. The second line shows set level and sequence operation mode.

7) Battery Discharge Operation:

The first line shows actual voltage, current, battery capacity and discharge time.

8) Short Circuit Operation:

The LCD shows actual voltage, current, power and resistance levels. The second line shows set level in short circuit mode. Please refer to Main Specifications for details.

9) Protection Status

If the protection function is active, the indicator of “Cancel” is turned on, LCD will display corresponding protection status. For example: the display of reverse voltage protection status is shown as below: Protection status includes overcurrent (OC), overvoltage (OV), overpower (OP), overtemperature (OT), load protection (PT), and reverse voltage (RV).

10) Input On/Off

When the indicator of “On/Off” is turned on, the load’s input is in On status; on the contrary, the load’s input is in Off status.

2.9. Remote Programming

The commands are sent to electronic load via remote interface (RS232), and will be executed after decoding by the processor. If there is any error occurs to the command, the processor can detect the wrong command and error type, and it can maintain the status register as well.

When the instrument address is set between 32 and 255, the address value should be added at the head of commands. When the instrument address is set higher than 256, the address become invalid, and the address value does not need to be added at the head of commands.

3. Functions and Features

3.0.

The functions and features of electronic load will be described in this chapter, which helps you to know this series better.

3.1. Local and Remote Control

This series electronic load can be controlled via the front panel, or by remote controller via remote interface. If it is needed to control the load via the front panel, the load has to stay in local control status. Local (front panel) control is in effect immediately after power is applied. Remote control goes into effect as soon as the load receives a SYSTem:REMote command via RS232.





Under remote control status, the REM annunciator is turned on, all operations on front panel keypad and knobs become invalid (except “Lock/Local” key). All operations on electronic load are controlled by remote controller. The electronic load will return to local control and REM remote control annunciator is turned off after receiving the return command (e.g. : SYST:LOC). Or you can return the electronic load to local control by long -pressing “Lock/Local” key.

Details of local operation are covered in Chapter Local Operation and fundamentals of remote programming are given in Chapter Remote Operation. Complete SCPI programming details are given in the “Electronic Load SCPI Programming Guide”.

3.2. Main Function

Main functions (features) of electronic load:

- Constant Current Mode (CCL, CCH)
- Constant Voltage Mode (CVL, CVH)
- Constant Resistance Mode (VL CRL, VL CRM, VL CRH, VH CRL, VH CRM, VH CRH)
- Constant Power Mode (CPV, CPC)
- Transient Operation (Tran)
- Sequence (List) Operation (List)
- Battery Discharge Operation (Battery)
- Short Circuit Operation (Short)

3.3. Basic Test Function

3.3.0.

There are four modes of operation: constant current(CC), constant voltage(CV), constant resistance(CR), constant power(CP), and nine test modes: CCL, CCH, CVL, CVH, CRL, CRM, CRH, CPV, CPC.

The test mode and the associated parameters can be set via front panel or remote command. The load will remain in that mode until the mode is changed. If the mode is changed when the load’s input is in ON status, the load will be turned off automatically.

The set value for electronic load becomes effective immediately when the load is turned on. If the input set value exceeds the allowed range, it will be automatically limited at maximum value or minimum value.

3.3.1. Constant Current Mode (CC)

3.3.1.0.

Constant current mode has two ranges, the high range(CCH) and the low range(CCL). The high range provides wider test range. The low range provides better resolution at low current settings. In CC mode,





the load will sink a current in accordance with the programmed value regardless of the input voltage(see fig.3-1). Press “I-set” key in basic mode to enter into CC mode selection and parameter setting menu. Input the current level via the Entry keys or the knob with “◀” and “▶” keys. Use “Enter” key for confirmation. The CC mode and parameters can also be set via remote command (MODE CCL, MODE CCH, CURRent <NRf+>).

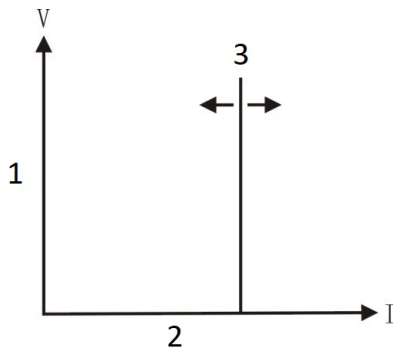

Fig. 3-1

- 1 - Input voltage
- 2 - Load Current
- 3 - Setting Current

3.3.1.1. Setting Ranges

In constant current low range (CCL) and in constant current high range (CCH), please refer to “Main Specifications” for the current setting range. If the range is changed in CC mode while the load’s input stays ON status, the load will be turned off automatically. For example: when the load is switched from CCL to CCH, the input will be turned off. Besides, it is noted that the current set level may have changed to fit the new range when the current range is changed. For example: the present setting is CCH 20.000A, when the load is switched from CCH to CCL, the current set level will change to the set level for CCL.

3.3.1.2. Immediate Current Level

The immediate current level refers to the current set value in CC mode, which can be set via pressing “I-set” key to enter into mode selection and parameter setting menu, or via remote command (CRRRent<NRf+>). The immediate current level can also be modified directly with left/right keys (“◀”, “▶”) and the knob.

3.3.1.3. Triggered Current Level

The triggered current level refers to the preset current value, which can become immediate current level automatically when a trigger is received. If the CC mode and the input are enabled, the input will be





updated immediately when a trigger occurs. If the CC mode is not active, this current level will have no effect on the input until the CC mode becomes active.

The triggered current level can be set via entry keys or remote command (CURRENT:TRIGgered <NRf+>). Once a current level is triggered, subsequent triggers will become invalid until another (CURRENT:TRIGgered <NRf+>) command is received. The trigger sources available to the load will be described in later chapter. The electronic load has a status register, which can keep track of pending triggers and other operating conditions. This status register will be described in details in the “Electronic Load SCPI Programming Guide”.

3.3.1.4. Transient Current Level

The load will switch between the transient high current level (LevelH) and transient low current level (LevelL) when the transient operation is enabled. The transient current level can be set in transient operation menu from the front panel, or via remote command (CURRENT:HLEV <NRf+>, CURRENT:LLEV <NRf+>).

3.3.1.5. Software Current Limit

The electronic load allows the user to set a current limit via pressing corresponding key or remote command (CURRENT:PROTection <NRf+>). The load will be turned off with beeping alarms if the current limit is exceeded beyond a programmable time delay (0.001-60s). Please note that the software current limit is in effect for any mode of operation.

3.3.2. Constant Voltage Mode (CV)

3.3.2.0.

In CV mode, the load will attempt to sink enough current to control the source voltage to the programmed value regardless of the input current (see fig.3-2). Press “V-set” key in basic mode to enter into CV mode selection and parameter setting menu. Input the voltage value via the Entry keys or the knob with “◀” and “▶” keys. Use “Enter” key for confirmation. The CV mode and parameters can also be set via remote command (MODE CV, VOLTage <NRf+>).

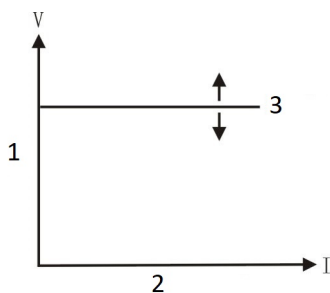

Fig. 3-2





- 1 - Input voltage
- 2 - Load Current
- 3 - Setting Voltage

3.3.2.1. Setting Ranges

Please refer to “Main Specifications” for details of the voltage setting ranges.

3.3.2.2. Immediate Voltage Level

The immediate voltage level refers to the voltage set value in CV mode, which can be set via pressing “V-set” key to enter into mode selection and parameter setting menu, or via remote command (VOLTage:NRf+>). The immediate current level can also be modified directly with left/right keys (“◀”, “▶”) and the knob.

3.3.2.3. Triggered Voltage Level

The triggered voltage level refers to the preset voltage value, which can become immediate voltage level automatically when a trigger is received. If the CV mode and the input are enabled, the input will be updated immediately when a trigger occurs. If the CV mode is not active, this voltage level will have no effect on the input until the CV mode is active.

The triggered voltage level can be set via entry keys or remote command (VOLTage:TRIGgered<NRf+>). Once a voltage level is triggered, subsequent triggers will become invalid until another (VOLTage:TRIGgered <NRf+>) command is received. The trigger sources available to the load will be described in later chapter. The electronic load has a status register, which can keep track of pending triggers and other operating conditions. This status register will be described in details in the “Electronic Load SCPI Programming Guide”.

3.3.2.4. Transient Voltage Level

The load will switch between the transient high voltage level (LevelH) and transient low voltage level (LevelL) when the transient operation is enabled. The transient voltage level can be set in transient operation menu from the front panel, or via remote command (VOLTage:HLEVel <NRf+>, VOLTage:LLEVel <NRf+>).

3.3.3. Constant Resistance Mode (CR)

3.3.3.0.

Constant resistance mode has six ranges: the low level (VL CRL), medium level (VL CRM), high level (VL CRH) of the low voltage range and the low level (VH CRL), medium level (VH CRM), high level (VH CRH) of the high voltage range. In CR mode, the load will sink a current linearly proportional to the input voltage in accordance with the programmed resistance to make $I=U/R$ (see fig. 3-3). Press “R-set” key in basic mode to enter into CR mode selection and parameter setting menu. Input the resistance value via the Entry keys





or the knob with “◀” and “▶” keys. Use key “Enter” for confirmation. The CR mode and parameters can also be set via remote command (MODE VLCL, MODE VLCRM, MODE VHCRH, RESistance <NRf+>).

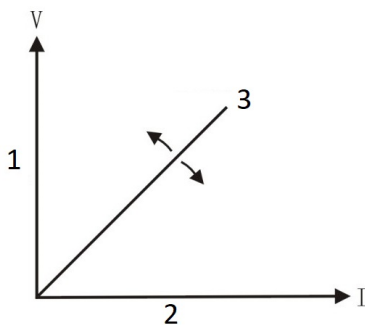

Fig. 3-3

- 1 - Input voltage
- 2 - Load Current
- 3 - Slope (Setting Resistance)

3.3.3.1. Setting Ranges

In constant resistance low range (CRL), medium range (CRM), and high range (CRH), the resistance setting range is in “Main Specifications” section. If the range is changed in CR mode while the Load’s input stays ON status, the load will be turned off automatically. For example: when the load is switched from CRL to CRH, the input will be turned off. Besides, it is noted that the resistance set level may have changed to fit the new range when the resistance range is changed. For example: the present setting is CRM 10.000Ω, when the load is switched from CRM to CRL, the resistance set level will change to the maximum level 1.5000Ω for CRL.

3.3.3.2. Immediate Resistance Level

The immediate resistance level refers to the resistance set value in CR mode, which can be set via pressing “R-set” key to enter into mode selection and parameter setting menu, or via remote command (RESistance <NRf+>). The immediate resistance level can also be modified directly with left/right keys (“◀”, “▶”) and the knob.

3.3.3.3. Triggered Resistance Level

The triggered resistance level refers to the preset resistance value, which can become immediate resistance level automatically when a trigger is received. If the CR mode and the input are enabled, the input will be updated immediately when a trigger occurs. If the CR mode is not active, this resistance level will have no effect on the input until the CR mode becomes active.





The triggered resistance level can be set via entry keys or remote command (RESistance:TRIGgered <NRf+>). Once a resistance level is triggered, subsequent triggers will become invalid until another (RESistance:TRIGgered <NRf+>) command is received. The trigger sources available to the load will be described in later chapter. The electronic load has a status register, which can keep track of pending triggers and other operating conditions. This status register will be described in details in the “Electronic Load SCPI Programming Guide”.

3.3.3.4. Transient Resistance Level

The load will switch between the transient high resistance level (LevelH) and transient low resistance level (LevelL) when the transient operation is enabled. The transient resistance level can be set in transient operation menu from the front panel, or via remote command (RESistance:HLEVEL <NRf+>, RESistance:LLEVEL <NRf+>).

3.3.4. Constant Power Mode (CP)

3.3.4.0.

There are two sorts of constant power modes, the Constant Power-Voltage Source mode (CPV) and the Constant Power-Current Source mode (CPC). The CPV mode is applied to voltage source test, and the CPC mode is applied to current source test. In CP mode, the load consumes the constant power in accordance with the programmed value regardless of the changes of external current and voltage (see fig.3-4). Press “P-set” key to enter into CP mode selection and parameter setting menu. Input the power value via Entry keys or the knob with “◀” and “▶” keys. Use “Enter” key for confirmation. The CP mode and parameters can also be set via remote command (MODE CPV, MODE CPC, POWER <NRf+>).

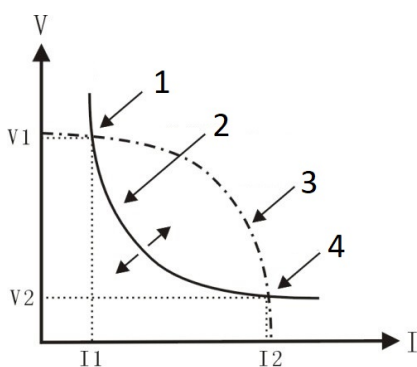

Fig. 3-4

- 1 - CPV Mode
- 2 - Setting Power





3 - Current-Voltage Curve

4 - CPC Mode

Figure 3-5 are the current-voltage curves for several common power supplies. The constant power curve is a hyperbola in the first quadrant. The constant power curve usually intersects with current-voltage curve at two points (the CPV point and the CPC point) when the power of the external power supply is larger than the set power. At the CPV point, the power supply shows the feature of voltage source: the output power will be increased with increasing current; at the CPC point, the power supply shows the feature of current source: the output power will be increased with increasing voltage.

This series electronic load can be set at any one of intersection points to operate by the user.

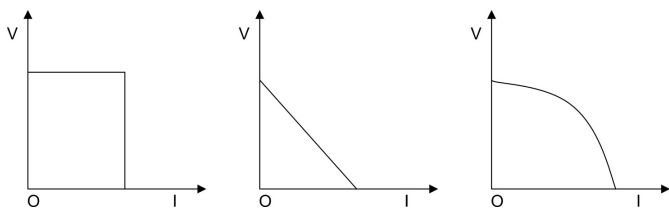

As CPV adopts advanced slope detection method, this series electronic load only has to test a part of the current-voltage curve to know whether the two curves (constant power curve and current-voltage curve) intersect. Therefore, when the set power is larger than the actual power, the external power supply will not be short-circuited by the load because the power is insufficient. When the load detects that the power of the external power supply is insufficient, the current will stop to be increased at once, and the load will try to find constant power point again till the set power is met.

In CPC mode, the load short-circuits at first to detect the constant current level of the external power supply, and calculate the maximum output power. If the output power is less than the set power, the input will be turned off immediately; If the output power is larger than the set power, the load will try to find constant power point again till the set power is met.

3.3.4.1. Setting Ranges

Please refer to “Main Specifications” section for the detailed CPV and CPC setting ranges.

3.3.4.2. Immediate Power Level

The immediate power level refers to the power set value in CP mode, which can be set via pressing “P-set” key to enter into CP mode selection and parameter setting menu, or via remote command (POWER <NRf+>). The immediate resistance level can also be modified directly with left/right keys (“◀”, “▶”) and the knob.

3.3.4.3. Triggered Power Level

The triggered power level refers to the preset power value, which can become immediate power level automatically when a trigger is received. If the CP mode and the input are enabled, the input will be updated





immediately when a trigger occurs. If the CP mode is not active, this power level will have no effect on the input until the CP mode becomes active.

The triggered power level can be set via entry keys or remote command (POWER:TRIGgered <NRf+>). Once a power level is triggered, subsequent triggers will become invalid until another (POWER:TRIGgered <NRf+>) command is received. The trigger sources available to the load will be described in later chapter. The electronic load has a status register, which can keep track of pending triggers and other operating conditions.

This status register will be described in details in the “Electronic Load SCPI Programming Guide”.

3.4. Transient Operation

3.4.0.

When the transient operation is enabled, the load periodically switch between two levels (LevelH and LevelL), which can be applied to test the dynamic characteristics of the power supply. The transient operation can be executed in the CC, CV, CR modes, and has three operating statuses: Continuous, Pulsed, and Toggled. Please make sure the sequence (List) operation has been disabled before enabling transient operation.

The parameters associated with transient operation are: low level (LevelL), high level (LevelH), low level time (TimeL), high level time (TimeH), time for rising edge (TimeR), time for falling edge (TimeF), and operating mode.

Transient high/low level and corresponding CC, CV, CR modes share one setting range.

Transient test can be turned on and off via key at the front panel or via remote command (TRANSient ON/OFF). Before you turn on transient test, you should set the load to the desired mode.

△ Note:

In transient test, the Von point and current limit should be taken into consideration, which may cause the shut down of the input, so that the transient test is interrupted.

3.4.1. Continuous Transient Operation

In continuous operation, the load periodically switches between high/low levels. The trigger function has no effect on this continuous transient operation. The relevant (the associated) parameters such as low level (LevelL), high level (LevelH), low level time (TimeL), high level time (TimeH), time for rising edge (TimeR), time for falling edge (TimeF), and continuous transient operation can be set through transient operation menu or via remote command (CURRENT:LLEVEL <NRf+>, CURRENT:HLEVEL <NRf+>, VOLTage:LLEVEL <NRf+>, VOLTage:HLEVEL <NRf+>, RESistance:LLEVEL <NRf+>, RESistance:HLEVEL <NRf+>, TRANSient:LTIME <NRf+>, TRANSient:HTIME <NRf+>, TRANSient:RTIME <NRf+>, TRANSient:FTIME <NRf+>, TRANSient:MODE CONTInuous).

For example: assume that the CCH range is active, and the input is in OFF status, then the transient parameters should be set as follows:





Press “Tran” key to enter into transient operation;

Set the following parameters in transient operation menu:

State : On

Mode : Cont

LevelL : 5.000A

LevelH : 10.000A

TimeL : 0.50ms

TimeH : 0.50ms

TimeR : 0.25ms

TimeF : 0.25ms

Then press “Cancel” to exit transient operation, press “On/Off” key to turn on the input;

Or via remote command to set:

SCPI command - Description

MODE CCH - Sets operating mode

TRAN ON - Enables transient operation

CURR:LLEV 5 - Sets transient current low level to 5A

CURR:HLEV 10 - Sets transient current high level to 10A

TRAN:LTIM 0.000500 - Sets transient low level time to 500us

TRAN:HTIM 0.000500 - Sets transient high level time to 500us

TRAN:RTIM 0.000250 - Sets the time for transient rising edge to 250us

TRAN:FTIM 0.000250 - Sets the time for transient falling edge to 250us

TRAN:MODE CONT - Selects continuous operation

INPUT ON -Turns on the input

Figure 3-6 shows the current waveform of the load: the load’s input current reaches the transient high level (10A) after 250us duration of rising edge, and remains at 10A for 500us. Then after 250us duration of falling edge, the input current reaches the transient low level (5A), and remains at 5A for 500us. Repeat it in cycles.

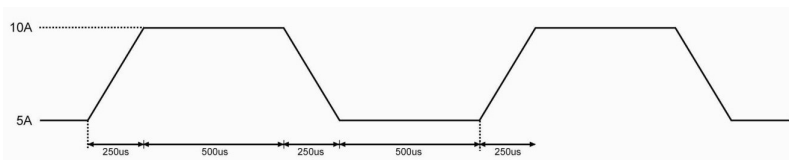

Fig. 3-6

3.4.2. Pulsed Transient Operation

The trigger function is required for pulsed transient operation. When there is no trigger occurs, the load remains at the transient low level. After a trigger has been received, a pulse will be appeared with rising





edge, transient high level, and falling edge three stages, then the load returns to the transient low level again at last. The associated parameters such as transient low level (LevelL), transient high level (LevelH), high level time (TimeH), time for rising edge (TimeR), time for falling edge (TimeF), and pulsed transient mode can be set through transient operation menu or via remote command (CURRent:LLEVel <NRf+>, CURRent:HLEVel <NRf+>, VOLTage:LLEVel <NRf+>, VOLTage:HLEVel <NRf+>, RESistance:LLEVel <NRf+>, RESistance:HLEVel <NRf+>, TRANsient:HTIME <NRf+>, TRANsient:RTIME <NRf+>, TRANsient:FTIME <NRf+>, TRANsient:MODE PULSe). The low level time (TimeL) has no effect on pulsed transient operation.

In order to get a pulse, an explicit trigger is required. The trigger can be an external trigger signal received via the TRIG input on the rear panel, pressing the “Shift”+ “0Trigger” keys, the *TRG common command, or the TRIG subsystem command. The trigger becomes effective only when the load remains at transient low level. Each trigger leads to one pulse. In the duration of rising edge, transient high level, and falling edge, any trigger will be ignored.

For example: assume that the CCH range is active, and the input is in OFF status, then the transient parameters should be set as follows:

Press “Tran” key to enter into transient operation;

Set the following parameters in transient operation menu:

State : On

Mode : Puls

LevelL : 5.000A

LevelH : 10.000A

TimeL : 0.50ms

TimeH : 0.50ms

TimeR : 0.5ms

TimeF : 0.5ms

Then press “Cancel” to exit transient operation, press “On/Off” key to turn on the input;

Or via remote command to set:

SCPI command - Description

TRIG:SOUR EXT - Selects the external trigger input

TRAN ON - Enables transient operation

CURR:LLEV 5 - Sets transient current low level to 5A

CURR:HLEV 10 - Sets transient current high level to 10A

TRAN:HTIM 0.000500 - Sets transient high level time to 500us

TRAN:RTIM 0.000500 - Sets the time for transient rising edge to 500us

TRAN:FTIM 0.000500 - Sets the time for transient falling edge to 500us

TRAN:MODE PULS - Selects pulse trigger operation

INPUT ON - Turns on the input

Get the trigger by receiving an external trigger signal. Figure 3-7 shows the current waveform of the load before it is triggered and after it has been triggered respectively: the electronic load starts operation at the



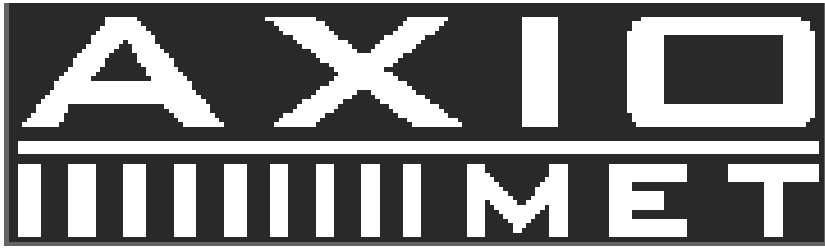

transient low level (5A) when the input is turned on. For each trigger, the load current reaches the high level (10A) after 500us duration of rising edge, and remains at 10A for 500us. Then after 500us duration of falling edge, the current returns to the transient low level (5A).

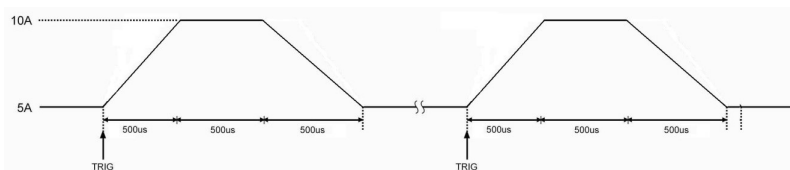

Fig. 3-7

3.4.3. Toggled Transient Mode

The trigger function is required for toggled transient operation. When there is no trigger occurs, the load remains at a transient level. After a trigger has been received, a toggle operation will be executed, and another transient level will be reached after the duration of rising edge or falling edge. The associated parameters such as transient low level (LevelL), transient high level (LevelH), time for rising edge (TimeR), time for falling edge (TimeF), and toggled transient mode can be set through transient operation menu or via remote command (CURRent:LLEVel <NRf+>, CURRent:HLEVel <NRf+>, VOLTage:LLEVel <NRf+>, VOLTage:HLEVel <NRf+>, RESistance:LLEVel <NRf+>, RESistance:HLEVel <NRf+>, TRANsient:RTIME <NRf+>, TRANsient:FTIME <NRf+>, TRANsient:MODE PULSe). The low level time (TimeL) and high level time (TimeH) have no effect on toggled transient operation.

The trigger can be an external trigger signal received via the TRIG input on the front panel, pressing the “Shift”+“0Trigger” keys, the *TRG common command, or the TRIG subsystem command.

For example: assume that the CCH range is active, and the input is in OFF status, then the transient parameters should be set as follows:

Press “Tran” key to enter into transient operation;

Set the following parameters in transient operation menu:

State : On

Mode : Togg

LevelL : 5.000A

LevelH : 10.000A

TimeL : 0.50ms

TimeH : 0.50ms

TimeR : 0.50ms

TimeF : 0.50ms

Then press “Cancel” to exit transient operation, press “On/Off” key to turn on the input;



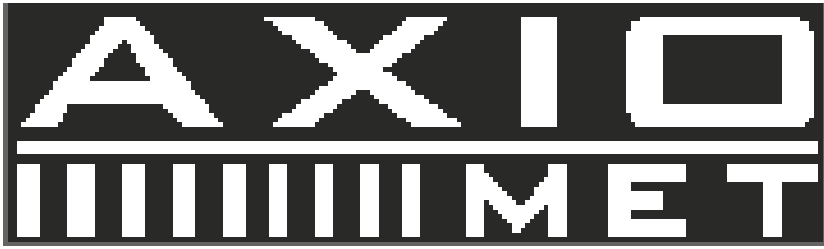

Or via remote command to set:

SCPI command - Description

TRIG:SOUR EXT - Selects the external trigger input

TRAN ON - Enables transient operation

CURR:LLEV 5 - Sets transient current low level to 5A

CURR:HLEV 10 - Sets transient current high level to 10A

TRAN:LTIM 0.000500 - Sets transient low level time to 500us

TRAN:HTIM 0.000500 - Sets transient high level time to 500us

TRAN:RTIM 0.000500 - Sets the time for transient rising edge to 500us

TRAN:FTIM 0.000500 - Sets the time for transient falling edge to 500us

TRAN:MODE TOGG - Selects toggled operation

INPUT ON - Turns on the input

Get the trigger by receiving an external trigger signal. Figure 3-8 shows the current waveform of the load before it is triggered and after it has been triggered respectively: the electronic load starts operation at the transient low level (5A) when the input is turned on. For the first trigger, the load current reaches and remains at the high level (10A) after 500us duration of rising edge. When the second trigger is received, the load current will reach and remain at the low level (5A) after 500us duration of falling edge. Each trigger leads to one toggle operation.

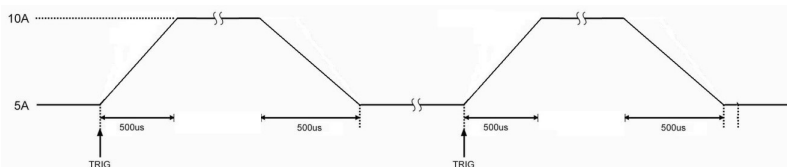

Fig. 3-8

3.5. Sequence (List) Operation

Besides Transient operation, the electronic load provides more flexible list operation, which can make the load operate according to the preset sequence and synchronize with external signal.

The list operation allows you to program a series of sequence steps, and the operation mode, the load values, the duration time for each step can be set. The sequence operation can be executed in the CC, CV, and CR modes. The minimum duration for each step is 10ms (the duration to 0 indicates the current step is invalid), and the maximum one is 99999s. The list operation allows to be executed cyclically, and the cycle times can be set; the different list can be chained so that when one list has been executed, the





another chained list will be enabled, which further perfects the capability of the list test to implement more complicated test task. Each list can contain 50 steps at most, and the load can store 8 lists. The associated parameters of list operation can be edited and set through list operation menu or via remote command. The load provides convenient list editing function. When the user is operating input/edit sequence step, it is easy to check the previous and subsequent steps, and it is allowed to be edited, inserted, and deleted immediately, which simplifies the list input operation effectively.

The set value of each step will be automatically saved when exiting from step edit menu, and the other list parameters will be saved immediately after been edited. The list operation also can be implemented via the remote command.

Please make sure the transient operation has been disabled before enabling list operation. In list operation, if the operation mode for next step is different from the present step, the load will automatically have a 5ms delay after the present step is over to avoid the probable current surge. The load's input will be turned off during this 5ms-delay.

Figure 3-9 is a list running diagram for 5 steps. See chapter 4 for detailed information about programming lists from the front panel.

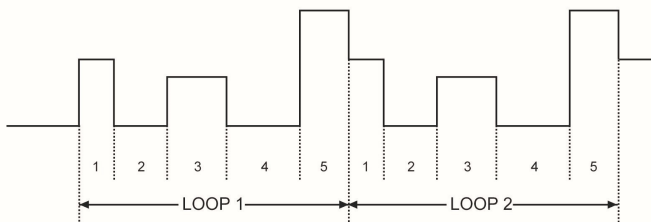

Fig. 3-9

△ Note:

In list operation, the Von point and current limit level should be taken into consideration, which may cause the shut down of the input, so that the list operation is interrupted.

3.6. Battery Discharge Operation

The electronic load adopts constant current discharge to test battery capacity. The discharge current, termination voltage, and termination current can be self-defined. After the input is in ON status, constant current discharge is executed and switched to constant voltage discharge automatically when the battery voltage decreases to the termination voltage. And the battery discharge test will be stopped automatically when the discharge current is less than the termination current.



The test procedure is shown as figure 3-10. The load can real-time display battery voltage, discharge current, discharge time, and discharge capacity during the test. The maximum battery discharge time is 99hours 99minutes 99 seconds.

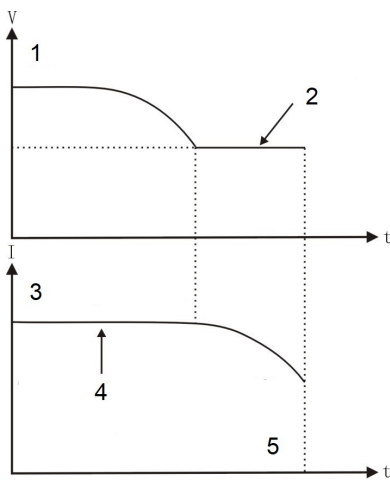

Fig. 3-10

- 1 - Battery Voltage
- 2 - Constant Voltage Discharge
- 3 - Discharge Current
- 4 - Constant Current Discharge
- 5 - Termination Current

3.7. Short Circuit Operation

The electronic load can simulate a short circuit to test the protection performance of the tested device. The short circuit operation can be enabled and disabled by setting in the main menu, or via the remote command (INPut:SHORT ON/OFF). When the short circuit operation is enabled, the relevant short-circuit value depends on the present mode of the load. See “Main Specifications” section for details.

The other set values will not be changed when the short circuit operation is enabled.

△ Note:

In short circuit operation, the Von point and current limit level should be taken into consideration, which may cause the shut down of the input, so that the short circuit operation is interrupted.



3.8. Triggered Operation

The triggered operation is mainly used to make the load keep synchronized with other test equipments or events. This series electronic load provides various triggering modes, which can be applied to the following occasions:

- Triggering a preset level

Transfers all pending preset levels to the immediate levels. For the presently active mode, the new level will appear at the input at once if the input is turned on. For the modes which are not presently active, the preset levels will not take effect at the input until the corresponding mode becomes active.

- Triggering a transient pulse

Generates a transient pulse in accordance with the preset transient parameters, when pulsed transient operation is active.

- Triggering a transient toggle

Switches the input between the transient low level and transient high level in accordance with the preset transient parameters, when the toggled transient operation is active.

- Triggering a list test

Enables the present list test when the list operation is active.

Three triggering methods are available for remote control: the *TRG and TRIGger commands. The External trigger input terminal and "Shift"+"0Trigger" key on the front panel of the load can be used to trigger (can generate a trigger signal to the electronic load).

The load has three triggering modes: BUS, EXTERNAL, and HOLD.

- The BUS mode: the trigger source is *TRG command.

- The EXTERNAL mode: Choose the External trigger input terminal or "Shift"+"0Trigger" key on the front panel as the trigger source. The input signal at the External trigger input terminal is TTL, the falling edge (signal) is triggered (can generate a trigger signal to the electronic load).

- The HOLD mode: Use the command TRIGger:IMMEDIATE as the trigger source. At this time, all other triggering methods including *TRG become invalid.

△ Note:

The command TRIGger:IMMEDIATE can be used in all three triggering modes. The triggering modes can be selected via the remote command only (TRIGger:SOURce BUS; TRIGger:SOURce EXTERNAL; TRIGger:SOURce HOLD).

3.9. Input Control

3.9.1. Turn On/Off the Load

The input can be turned on/off by pressing "On/Off" key, or via the remote command (INPUT ON/OFF). When input is in Off status, press "On/Off" to turn on the input of load and the indicator of "On/Off" is turned on; When input is in On status, press "On/Off" to turn off the input of load and the indicator of "On/Off" is turned off; Turning the input on/off does not affect the programmed settings.





In local control, if the input is turned on, the load status can not be switched directly among the basic modes, transient operation, list operation and battery discharge operation etc.. The load can be switched from one operation status to another operation status only when the input is turned off.

In remote control mode, it is better to send the command “INPUT ON/OFF” in the end to turn on the load.

3.9.2. Von Point / Voff Point / Von Latch

When the rising speed or falling speed of tested power supply is slow, the load maybe protect the tested power supply. The load provides functions of Von Point and Voff Point. When the voltage of tested power supply goes up untill exceeds the Von Point, the load starts Von test. Once the voltage of tested power supply is more than the Voff Point, the voltage will drop down till less than the Voff Point, at this time, the load is in Voff status and the input is in Off status.

When the external input voltage is less than the Von Point, the load will not be enabled even though the input has been turned on. The load will be enabled till the external input voltage reaches or exceeds the Von Point.

Von Latch is used to latch the active status of the load. If the Von Latch function is enabled, once the input voltage reaches Von Point, the input will be turned on, and stay in ON status regardless of the changes from the external input voltage, even though the input voltage is less than the Von point. Please see figure 3-11; if the Von Latch function is disabled, once the input voltage reaches Von Point, the input will be turned on automatically, and once the input voltage is less than the Von Point, the input will be automatically turned off. Please see figure 3-12. The automatically turning on /off of the input can be implemented via setting the Von Point and Von Latch, which simplifies test operation greatly.

The Von Voltage can be set in main menu, or via the remote command (INPut:VOLTage:ON <NRf+>).

The Voff Voltage can be set in main menu, or via the remote command (INPut:VOLTage:OFF <NRf+>).

The Von Latch can be set in main menu, or via the remote command (INPut:VOLTage:ON:LATCh ON/OFF).



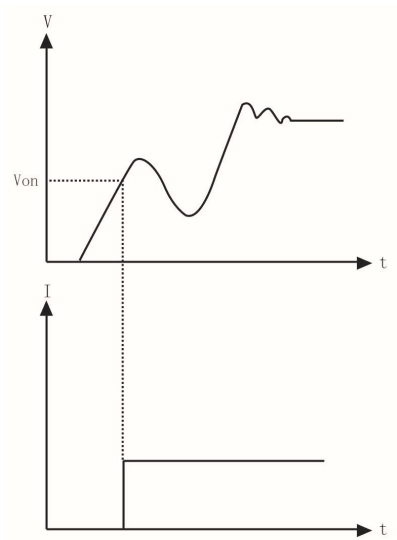

Fig. 3-11

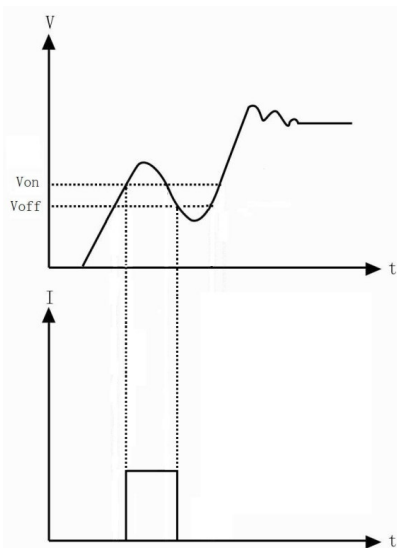

Fig. 3-12

△ Note:





If the load is unable to operate normally, please check the setting of Von Point and Voff Point.

3.9.3. Current Limit in CV Mode

The CV Curr Limit is used to limit the maximum input current in CV mode. If the voltage is still larger than the set level while the current limit has been reached, the load will switch to the CC mode. Please see figure 3-13. The input will not be turned off in the CV current limit, which is different from the software current limit.

The CV Curr Limit can be set in main menu, or via the remote command (CV:CURRent:LIMIt <NRf+>).

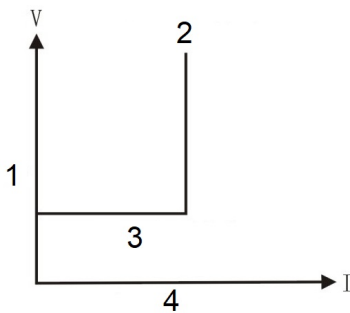

Fig. 3-13

- 1 - Input voltage
- 2 - Current Limit
- 3 - Setting Voltage
- 4 - Load Current

3.9.4. Current Rise Rate

The Current Rise Rate is used to set the current rise rate in CC mode. It can be set in main menu, or via the remote command (CURRent:RISE:RATE <NRf+>).

If the current rise rate is 0.1A/us, and the current set level is 20A, then the current rise rate is shown as below when the input is turned on:



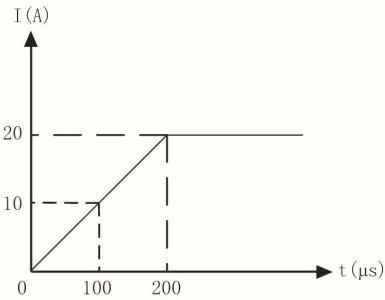

Fig. 3-14

△ Note:

The Current Rise Rate can be effective only in CCH and CCL, and the set level is 10 times larger than the maximum current rise rate in CCL.

3.9.5. Current Fall Rate

The Current Fall Rate is used to set the current fall rate in CC mode. It can be set in main menu, or via the remote command (CURRENT:FALL:RATE <NRf+>).

If the current fall rate is 0.1A/us, and the current set level is 20A, then the current rise rate is shown as below when the input is turned off:

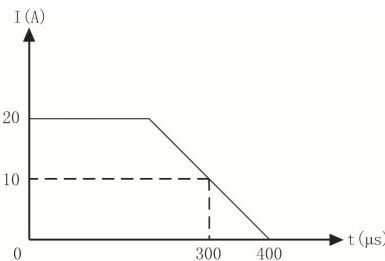

Fig. 3-15

△ Note:

The Curr Fall Rate can be effective only in CCH and CCL mode, and the set level is 10 times larger than the actual current fall rate in CCL.

3.10. Measurement Function

The electronic load has measurement system with high resolution. The input current level and voltage level can be measured in real time. The input power level and resistance level can be computed with the





input voltage level and current level. Each measured value can be checked through LCD display or via the command (MEASure).

3.11. Saving and Recalling

The electronic load is provided with a EEPROM memory, which can save various parameters, such as modes, input status, current, voltage, resistance, transient settings, and limits etc.. This Series electronic load can save 10 groups of parameters. All parameters relevant to saving and recalling operation are listed in list 3-1.

The 10 groups of parameters stored in location 0~9 can be saved and recalled by pressing “1Store” and “2Recall” keys, or via the remote command (*SAV < NRl > and *RCL < NRl >).

The parameter saved in location 0 will be recalled automatically every time when the load is turned on.

List 3-1

Function /// Effect

Input /// Input status

Mode /// Operation mode

CCL Current level /// CCL immediate current level

CCH Current level /// CCH immediate current level

Current rise rate /// Current rise rate

Current fall rate /// Current fall rate

Current Hlevel /// Transient current high level

Current Llevel /// Transient current low level

Current protection level /// Current protection limit

Current protection delay /// Current protection delay

Current protection State /// Enable/disable current protection

CVL Voltage level /// CVL immediate voltage level

CVH Voltage level /// CVH immediate voltage level

Voltage protection level /// Voltage protection limit

Power protection level /// Power limit

CV current limit /// Current limit in CV mode

Voltage Hlevel /// Transient voltage high level

Voltage Llevel /// Transient voltage low level

CRL Resistance level /// CRL immediate resistance level

CRM Resistance level /// CRM immediate resistance level

CRH Resistance level /// CRH immediate resistance level

Resistance Hlevel /// Transient resistance high level

Resistance Llevel /// Transient resistance low level

CPV Power level /// CPV immediate power level





CPC Power level /// CPC immediate power level
Transient operation /// Transient test
Transient mode /// Transient mode
Transient Htime /// Time for transient high level
Transient Ltime /// Time for transient low level
Transient Rtime /// Time for transient rising edge
Transient Ftime /// Time for transient falling edge
Trigger Function /// Trigger function selection
Trigger source /// Trigger source
Battery Mode /// Battery discharge operation
Battery mini voltage /// Battery discharge termination voltage
Battery discharge current /// Battery discharge current
Voltage on Latch /// Latch the Von point
Voltage on /// Von point for the load
Voltage off /// Voff point for the load

3.12. Reading Remote Programming Errors

The Err annunciator will be turned on when remote programming errors occur. The error codes are shown as followings:

- -1xx Command errors
- -2xx Execution errors
- -3xx Device-specific errors
- -4xx Query errors

The remote command (SYSTem:ERRor?) can reads back the error codes and error messages when it is in remote control.

All errors are saved in one error queue. The errors in this error queue are read in the order in which they occurred. At most 20 error messages can be saved in the error queue. If the occurred errors exceed 20, the last error in the error queue will be replaced with -350, "Queue overflow". The load will not save any additional error message, unless you clear or read errors from the queue. Once the error message is read, it will be cleared in the error queue.

3.13. Status Report

The electronic load incorporates a status reporting register. Various status conditions of the load can be reported by querying the status register. The user can make sure which event has been reported through setting the enable register (It will be introduced in details in "ElectronicLoad SCPI Programming Guide").





3.14. Protection Function

3.14.0.

The electronic load is equipped with the following protection functions:

- Overvoltage (OV)
- Overcurrent (OC)
- Overpower (OP)
- Overtemperature (OT)
- Reverse Voltage (RV)

Once any of the above protection functions is active, the corresponding status bit in the status will be set; the input will be turned off with beeps; the annunciator of “Cancel” will be turned on, the display will show PT to indicate protection status the detected conditions will be displayed; the load will enter into the latched protection status, and will not respond to other commands except some specific operations. For example: if an overtemperature conditions has been detected, the input will be turned off with beeps, and OT will be shown in the lower right corner of the display. The load will have no response to other operations.

3.14.1. Clearing Latched Protection

When the load enters into the latched protection status, it will have no response to other commands. The load will return to the normal operation only when the latched protection has been reset via long pressing the “Cancel” key or the remote command (INPut:PROTection:CLEar). Of course, the condition that cause the latched protection must be removed, or it will be latched again as soon as it is reset.

In addition, when the software overcurrent protection is enabled, if the overcurrent time does not exceed the specified protection time, the indicator of “Cancel” will be turned on, but the input will not be turned off. At this time, you can reset the overcurrent time via long-pressing “Cancel” key or the remote command (INPut:PROTection:CLEar).

3.14.2. Over Voltage

When the input voltage exceeds the predetermined voltage, the overvoltage protection will be enabled, and the input is turned off with OVP displayed, meanwhile, the OV and VF status register bits are set, and will remain set until they are reset and overvoltage condition is removed.

3.14.3. Over Current

The electronic load allows the user to define a current protection limit. When the defined current limit is exceeded, the overcurrent timer starts timing, and the indicator of “Cancel” will be turned on, but the input will not be turned off immediately. When the specified delay time is reached, the overcurrent protection will be enabled and the input is turned off with OCP displayed, meanwhile, the OC and PS status register bits are set, and will remain set until they are reset and overcurrent condition is removed. The current protection limit function can only be set via the entry key from the front panel and the remote command. It is turned on/off with the command (CURRent:PROTection:STATe ON/OFF). The current limit level is





set with the command (CURRENT:PROTECTION < NRf+>). The specified delay time to turn off the input can be set with the command (CURRENT:PROTECTION:DELAY < NRf+>).

3.14.4. Over Power

The electronic load provides software overpower protection function.

Once the input power exceeds the maximum rated power, the load will compute the present actual power. The overpower protection will become active as long as the overpower time exceeds the specified limit.

When the overpower protection is enabled, the input will be turned off with OPP displayed, meanwhile, the OP and PS status register bits are set, and will remain set until they are reset and overpower condition is removed.

3.14.5. Over Temperature

If the internal temperature of the load exceeds safe limits, the overtemperature protection will be enabled; the input will be turned off with OTP displayed, in the meantime, the OT and PS status register bits are set, and will remain set until they are reset and overtemperature condition is removed. You must wait until the load cools down to the normal temperature before you can reset the latched protection. The fans in the load will help to cool the load as quickly as possible.

3.14.6. Reverse Voltage

When reverse voltage is applied, the reverse voltage protection will be enabled; the input will be turned off and the indicator of "Cancel" is turned on, in the meantime, the RV and VF status register bits are set, and will remain set until they are reset and reverse voltage is removed.

3.15. Auxiliary Functions

3.15.1. Trigger Function Selection

The Trigger Function in Trigger Set menu is used to select the trigger object. Selecting "Tran" is used to trigger transient operation, and selecting "List" is used to trigger sequence (list) operation.

3.15.2. Knob Function

The Knob in Config menu is used to enable/disable the knob function. Select On to enable the knob function, and select Off to disable.

3.15.3. Key Sound

The Key Sound in Config menu is used to enable/disable the key sound. Select On to enable the key sound, and select Off to disable.





4. Installation

4.1. Initial Check

When you receive the load, please check it for any obvious damage that may have occurred during shipment. Keep the original packing materials in case the load has to be returned to factory in the future.

Please confirm that there are no broken keys or knobs, that the cabinet and panel surfaces are free of dents and scratches, and that the display is not scratched or cracked.

4.2. Environment/Installation Location

The load can operate at its full power within the temperature range of 0 °C to 40 °C, and at derated power from 40 °C to 55 °C, or the overtemperature protection will be caused.

Place the load in a location with good ventilation, and keep a distance from electromagnetic interference. Do not place the load in the flammable atmosphere.

Your load must be installed in a location that allows sufficient space at the sides and rear of the load for adequate air circulation. The fans cool the load by drawing in air through the sides and exhausting it out the back. The rubber bumpers must be removed for rack mounting.

4.3. Power-On/ Self-Test

A power-on self-test can inspect the basic operations of the load to assure you that the load is operational.

First, check AC power-line voltage to verify the power-line voltage selected by 110V/220V power selection switch on the bottom panel is in accordance with the proper voltage in your local place.

Connect the power-line cord and turn on the load. After around 20 minutes' warm-up of the load, the following test can be executed:

Connect the output of a power supply to the load's input with correct polarity to execute CCH 5A and CVH 5V operations. If the load works normally, it will draw 5A or set input voltage to 5V within the allowed tolerance.

4.4. Connections on the Rear Panel

The rear panel is shown as fig. 4-1, which mainly includes AC input part, external trigger input terminal, remote sensing terminal and communication interface part. The AC input part includes AC input socket, Fuse holder, and Line voltage switch on the bottom of panel. The interface part includes RS232 interface.



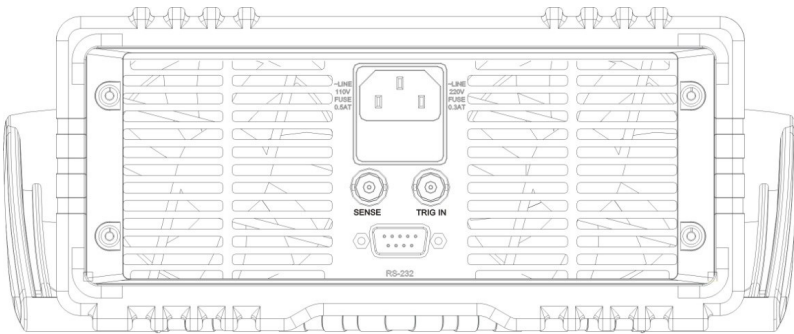

Fig. 4-1

AC Input:

AC power-line cord must be appropriate for your local standard.

The specifications of the fuse: 110V: 250V 500mA; 220V: 250V 300mA;

Line voltage switch can switch the voltage from 110V to 220V. The selected voltage should be in accordance with the proper voltage in your local place.

RS-232 Interface:

The load provides a RS-232 interface, which is a standard DB9 pin connector. The pin assignment is shown as below:

Pin /// Input/Output /// Description

- 1 /// - /// Not used
- 2 /// Input /// RXD: Receive data
- 3 /// Output /// TXD: Transmit data
- 4 /// - /// Not used
- 5 /// Common /// GND: Ground
- 6 /// - /// Not used
- 7 /// - /// Not used
- 8 /// - /// Not used
- 9 /// - /// Not used

The interface parameters can be set in the Menu, you can use SCPI language for programming to realize the communication with the load.

TRIGGER Connections:

The external trigger input terminal on the rear panel is a BNC connector, in which the middle part is the input+, and the outer casing is the input-. It receives 5V TTL-compatible falling-edge trigger signals.

Remote Sense:

Remote sensing is a BNC connector, in which the middle part is the SENSE+, and the outer casing is the SENSE-. It compensates for the voltage drop caused by the power supply and input wire resistance to



achieve greater accuracy. The load can detect voltage inputs automatically, so there is no need to modify the parameter settings or change the hardware wiring when using remote sensing.

4.5. Connections on the Front Panel

The terminals on the front panel are input terminals (INPUT+, INPUT-). See Fig. 4-2.

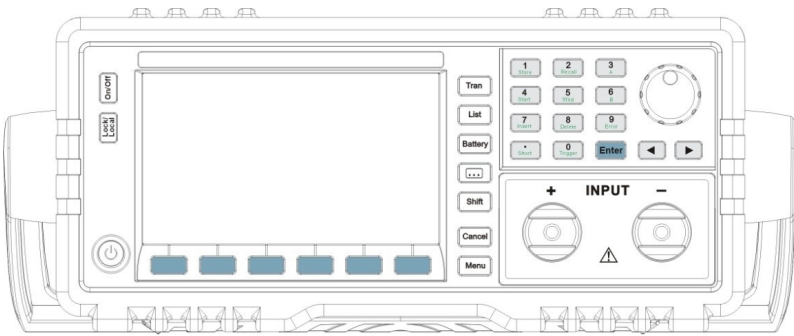

Fig. 4-2

Input Connections:

Input connections are made to two binding posts (INPUT+, INPUT-) on the front panel. The maximum wire diameter is 4mm. In order to enhance the test accuracy, and reduce the test error when executing large current test, it would be better to use thicker wire.

4.6. Wiring

Sense Connections

When greater accuracy of voltage test is needed, it is necessary to connect Sense input, and the load will switch to Sense status automatically. The relevant wiring is shown as fig. 4-3.

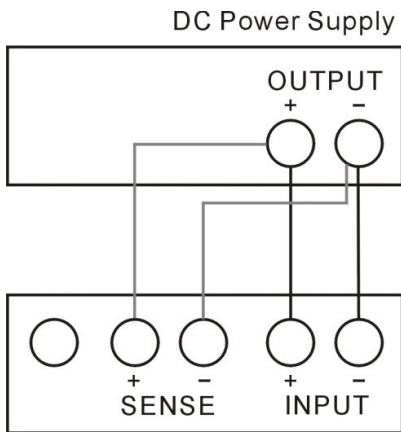

Fig. 4-3

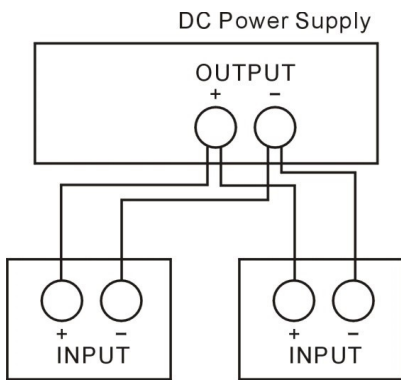

Fig. 4-4

Parallel Connections

Figure 4-4 illustrates how two or more loads can be paralleled in CC or CR mode when high power or large current is needed



5. Local Operation

5.0.

The local operation of the load has been briefly introduced in Chapter3 Functions and Features. In this chapter, it will be explained in details with examples.

5.1. Local Control

If you need to control the load via operations on the front panel, the load must stay in the local control status. The load enters into local control status once it is powered on, and preset parameters saved in EEPROM location 0 will be recalled automatically.

Under remote control status, all operations on front panel keypad and knobs become invalid (except “Lock/Local” key). When the load receives a remote command (SYST:REM) via RS232, the remote control goes into effect and Rmt annunciator is turned on. Under remote control status, all operations on electronic load are controlled by remote controller. The electronic load will return to local control after receiving the return command (e.g. : SYST:LOC). Or you can return the electronic load to local control by long-pressing “Lock/Local”key.

5.2. Main Operation on the Front Panel

- Connecting to the Power Supply
- Turning the Input On/Off
- CC Mode
- CV Mode
- CR Mode
- CP Mode
- Short Circuit Operation
- Continuous Transient Operation
- Pulsed Transient Operation
- Toggled Transient Operation
- Sequence (List) Operation
- Battery Discharge Operation
- Saving and Recalling Parameters
- Clear Protection Settings
- Error Messages
- Triggered Operation
- Main Menu





5.3. Connecting to the Power Supply

Connect the positive pole of the power supply to the INPUT + terminal, and connect the negative pole of the power supply to the INPUT - terminal. If the input is connected reversely, the RV protection status of the load will become effective, and please try to connect the power supply to the load again at this time.

After the power supply is correctly connected to the load, long-press “Cancel” key to clear the RV protection status (the relevant details will be described in “Clearing Protection Settings”).

5.4. Turning the Input On/Off

Press “On/Off” key to turn on or turn off the input.

5.5. Basic Tests

5.5.0.

The operating procedures for basic tests are shown as below:

- 1) Press “Menu” key to enter into the mode selection and parameter setting menu.
- 2) Use Entry keys or use the knob together with “◀”, “▶” keys to input set value. Use “Cancel” key to modify the set value or exit the mode selection and parameter setting menu.
- 3) Press “Enter” key to confirm and exit the mode selection and parameter setting menu.
- 4) Press “On/Off” key to turn on the load.

5.5.1. CC Mode

CC Mode includes constant current high range (CCH) and constant current low range (CCL).

Example1: Set the load to CCH and set the current value to 5.12A in CV mode. Turn on the load, and check the present power value. The operating procedures are shown as below:

Procedures /// Operation Descriptions /// Display

- 1 /// Press “Menu” key to enter into the selectable menu. /// MENU 0 SYST
- 2 /// Use Entry keys or use the knob to select “0 System Set”,press “Enter” key to confirm and enter into System Set. /// CC SET 0 Low
- 3 /// Use Entry keys or use the knob to select “1 High”,press “Enter” key to confirm. /// CC Set 1 High
- 4 /// Press “Cancel” key to exit and return to the basic mode. /// CVH 05.000V
- 5 /// Press “I-set” key to enter into the parameter setting menu. Use Entry keys or use the knob together with “t” and “u” keys to input the current value to 5.12. /// SCCH 05.120A
- 6 /// Press “Enter” key to confirm and exit the parameter setting menu. /// CCH 05.120A
- 7 /// Press “On/Off” key to turn on the load. ///

For the above operating procedures, the corresponding SCPI commands should be:

INPUT Off ; Turns off the load





MODE CCH ; Sets the mode

CURR 5.12 ; Sets the current value

INPUT ON ; Turns on the load

Example2: Set the current value to 5.8A in CCH. Turn on the load, and there are two ways to set the current value.

Solution 1:

Procedures /// Operation Descriptions /// Display

1 /// Press "I-set" key to enter into the parameter setting menu. /// SCCH 05.120A

2 /// Use Entry keys or use the knob together with "◀" and "▶" keys to input the current value to 5.8. /// SCCH 05.800A

3 /// Press "Enter" key to confirm and exit the parameter setting menu. /// CCH 05.800A

4 /// Press "On/Off" key to turn on the load. ///

Solution 2:

Procedures /// Operation Descriptions /// Display

1 /// Move the cursor to the hundredths with "◀" key. /// CCH 05.120A

2 /// Rotate the knob to set the hundredths to 0. (The set value will be changed when rotating the knob. The set value will become effective at input at once when the load is turned on.). /// CCH 05.100A

3 /// Move the cursor to the tenths with "◀" key. /// CCH 05. 100A

4 /// Rotate the knob to set the tenths to 8. (The set value will be changed when rotating the knob. The set value will become effective at input at once when the load is turned on.). /// CCH 05. 800A

5 /// Press "On/Off" key to turn on the load. ///

For the above operating procedures, the corresponding SCPI commands should be:

MODE CCH ; Sets the mode

CURR 5.8 ; Sets the current value

INPUT ON ; Turns on the load

△ **Note:**

CCH /CCL will be shown respectively in the lower right corner of the display when the load is in CCH status or CCL status.

5.5.2. CV Mode

Example1: Set the load to CCH and set the voltage value to 50V in CVH mode. Turn on the load, and check the present power value. The operating procedures are shown as below:

Procedures /// Operation Descriptions /// Display

1 /// Press "V-set" key to enter into the parameter setting menu. Use Entry keys or use the knob together with "◀" and "▶" keys to input the voltage value to 50. /// SCVH 50.000V

2 /// Press "Enter" key to confirm and exit the parameter setting menu. /// CVH 50.000V

3 /// Press "On/Off" key to turn on the load. ///

For the above operating procedures, the corresponding SCPI commands should be:

MODE CVH ; Sets the mode





VOLT 50 ; Sets the voltage value

INPUT ON ; Turns on the load

Example2: Set the voltage value to 60V in CV. Turn on the load, and there are two ways to set the voltage value.

Solution 1:

Procedures /// Operation Descriptions /// Display

1 /// Press “V-set” key to enter into the parameter setting menu. /// CVH 50.000V

2 /// Use Entry keys or use the knob together with “◀” and “▶” keys to input the voltage value to 60. /// CVH 60.000V

3 /// Press “Enter” key to confirm and exit the parameter setting menu. /// CVH 60.000V

4 /// Press “On/Off” key to turn on the load. ///

Solution 2:

Procedures /// Operation Descriptions /// Display

1 /// Move the cursor to the tenths with “◀” key. /// CVH 50.00V

2 /// Rotate the knob to set the tenths to 6. (The set value will be changed when rotating the knob. The set value will become effective at input at once when the load is turned on.). /// CVH 60.00V

3 /// Press “On/Off” key to turn on the load. ///

For the above operating procedures, the corresponding SCPI commands should be:

MODE CVH ; Sets the mode

VOLT 60 ; Sets the voltage value

INPUT ON ; Turns on the load

△ **Note:**

CVH will be shown in the lower right corner of the display when the load is in CV mode.

5.5.3. CR Mode

CR Mode includes the low level (VL CRL), medium level (VL CRM), high level (VL CRH) of the low voltage range and the low level (VH CRL), medium level (VH CRM), high level (VH CRH) of the high voltage range.

Example1: Set the load to VHCRL and set the resistance value to 1.5Ω. Turn on the load, and check the present power value. The operating procedures are shown as below:

Procedures /// Operation Descriptions /// Display

1 /// Press “Menu” key to enter into the selectable menu. /// MENU 0 SYST

2 /// Use Entry keys or use the knob to select “0 System Set”,press “Enter” key to confirm and enter into System Set. /// CC Set 1 High

3 /// Select “Syst CR Set” with “↑” and “↓” keys. /// CR Set 2 VH High

4 /// Use Entry keys or use the knob to select “0 Low”,press “Enter” key to confirm. /// CR Set 0 VH Low

5 /// Press “Cancel” key to exit and return to the basic mode. /// CVH 60.000V

6 /// Press “R-set” key to enter into the parameter setting menu. Use Entry keys or use the knob together





with “◀” and “▶” keys to input the resistance value to 1.5. /// SVHCRL 1.5000R
7 /// Press “Enter” key to confirm and exit the parameter setting menu. /// VHCRL 1.5000R
8 /// Press “On/Off” key to turn on the load. ///

For the above operating procedures, the corresponding SCPI commands should be:

MODE VHCRL ; Sets mode

RES 1.5 ; Sets the resistance value

INPUT ON ; Turns on the load

Example2: Set the resistance value to 1.2Ω in VH CRL. Turn on the load, and there are two ways to set the resistance value.

Solution 1:

Procedures /// Operation Descriptions /// Display

1 /// Press “R-set” key to enter into the parameter setting menu. /// SVHCRL 1.5000R

2 /// Use Entry keys or use the knob together with “◀” and “▶” keys to input the resistance value to 1.2. /// SVHCRL 1.2000R

3 /// Press “Enter” key to confirm and exit the mode selection and parameter setting menu. /// VHCRL 1.2000R

4 /// Press “On/Off” key to turn on the load. ///

Solution 2

Procedures /// Operation Descriptions /// Display

1 /// Move the cursor to the tenths with “◀” key. /// VHCRL 1.5000R

2 /// Rotate the knob to set the tenths to 2. (The set value will be changed when rotating the knob. The set value will become effective at input at once when the load is turned on.). /// VHCRL 1.2000R

3 /// Press “On/Off” key to turn on the load. ///

For the above operating procedures, the corresponding SCPI commands should be:

MODE VH CRL ; Sets mode

RES 1.2 ; Sets the resistance value

INPUT ON ; Turns on the load

△ **Note:**

CRH /CRM/CRL will be shown respectively in the lower right corner of the display when the load is in CRH status, CRM status or CRL status.

5.5.4. CP Mode

CP mode includes constant power-voltage source mode (CPV) and constant power-current source mode (CPC).

Example1: Set the load to CPV and set the power value to 100W in CRL. Turn on the load, and check the present power value. The operating procedures are shown as below:

Procedures /// Operation Descriptions /// Display

1 /// Press “Menu” key to enter into the selectable menu. /// MENU 0 SYST





- 2 /// Use Entry keys or use the knob to select "0 System Set",press "Enter" key to confirm and enter into System Set. /// CC Set 0 Low
- 3 /// Select "Syst CR Set" with "↑" and "↓" keys. /// CP Set 1 CPC
- 4 /// Use Entry keys or use the knob to select "0 CPV",press "Enter" key to confirm. /// CP Set 0 CPV
- 5 /// Press "Cancel" key to exit and return to the basic mode. /// VHCRL 1.200R
- 6 /// Press "P-set" key to enter into the parameter setting menu. Use Entry keys or use the knob together with "◀" and "▶" keys to input the power value to 100. /// SCPV 100.00W
- 7 /// Press "Enter" key to confirm and exit the parameter setting menu. /// CPV 100.00W
- 8 /// Press "On/Off" key to turn on the load. ///

For the above operating procedures, the corresponding SCPI commands should be:

MODE CPV ; Sets mode

POW 100 ; Sets the power value

INPUT ON ; Turns on the load

Example2: Set the power value to 200W in CPV. Turn on the load, and there are two ways to set the power value.

Solution 1:

Procedures /// Operation Descriptions /// Display

- 1 /// Press "P-set" key to enter into the parameter setting menu. /// SCPV 100.00W
- 2 /// Use Entry keys or use the knob together with "◀" and "▶" keys to input the power value to 200. /// SCPV 200.00W
- 3 /// Press "Enter" key to confirm and exit the mode selection and parameter setting menu. /// SCPV 200.00W
- 4 /// Press "On/Off" key to turn on the load. ///

Solution 2:

Procedures /// Operation Descriptions /// Display

- 1 /// Move the cursor to the hundredths with "◀" key. /// CPV 100.00W
- 2 /// Rotate the knob to set the hundredths to 2. (The set value will be changed when rotating the knob. The set value will become effective at input at once when the load is turned on.). /// CPV 200.00W
- 3 /// Press "On/Off" key to turn on the load. ///

For the above operating procedures, the corresponding SCPI commands should be:

MODE CPV ; Sets mode

POW 200 ; Sets the power value

INPUT ON ; Turns on the load

△ **Note:**

CPV/CPC will be shown respectively in the lower right corner of the display when the load is in CPV or CPV mode.





5.6. Short Circuit Operation

The operating procedures for short circuit operation are shown as below:

- 1) Press "Menu" key to enter into the selectable menu.
- 2) Use Entry keys or use the knob to select "0 System Set", and press "Enter" key to confirm and enter into System Set
- 3) Select Short (short circuit) item with "↓" key.
- 4) Operate all the above steps or press "Shift"+" Short" keys to select Short (short circuit) item.
- 5) Use Entry keys or knob to set On, and press "Enter" key to confirm.
- 6) Press "Cancel" key to exit the main menu. The display shows "s" to indicate in the basic test mode.
- 7) Select one basic test mode; press "Enter" key to confirm and exit the mode selection and parameter setting menu.
- 8) Press "On/Off" key to turn on the load.

Example1: The load was in CVH mode previously and it is turned off. Set the load to short circuit in CCH status. Turn on the load to execute short circuit operation.

Procedures /// Operation Descriptions /// Display

- 1 /// Press "Menu" key to enter into the selectable menu. /// MENU 0 SYST
- 2 /// Use Entry keys or use the knob to select "0 System Set", press "Enter" key to confirm and enter into System Set. /// CC Set 0 Low
- 3 /// Use Entry keys or use the knob to select "1 High", press "Enter" key to confirm. /// CC Set 1 High
- 4 /// Select Short (short circuit) item with "↓" key. /// SHORT 0Off
- 5 /// Use Entry keys or knob to set On, and press "Enter" key to confirm. /// SHORT 1On
- 6 /// Press "Cancel" key to exit the main menu. The display shows "s" to indicate in CVH mode. /// CVH 0.000V
- 7 /// Select CCH mode by pressing "I-set" key. press "Cancel" key to exit the mode selection and parameter setting menu. /// CCH 44.000A
- 8 /// Press "On/Off" key to turn on the load. ///

For the above operating procedures, the corresponding SCPI commands should be:

INPUT:SHORT ON ; Sets the load to short circuit operation

MODE CCH ; Sets mode

INPUT ON ; Turns on the load

Example2: Based on the last example, exit the short circuit operation, and turn off the load.

Procedures /// Operation Descriptions /// Display

- 1 /// Press "Menu" key to enter into the selectable menu and the load is turned off automatically. /// MENU 0 SYST
- 2 /// Use Entry keys or use the knob to select "0 System Set", press "Enter" key to confirm and enter into System Set. /// CC Set 0 Low
- 3 /// Use Entry keys or use the knob to select "1 High", press "Enter" key to confirm. /// CC Set 1 High
- 4 /// Select Short (short circuit) item with "↓" key. /// SHORT 0On
- 5 /// Use Entry keys or knob to set Off, and press "Enter" key to confirm. /// SHORT 1Off





6 /// Press “Cancel” key to exit the main menu. On the display, “s” disappears in CCH status. /// CVH 0.000V

For the above operating procedures, the corresponding SCPI commands should be:

INPUT:SHORT OFF ; Sets the load to exit short circuit operation

INPUT OFF ; Turns on the load

5.7. Transient Operation

5.7.0.

The operating procedures for transient operation are shown as below:

- 1) Select one basic test mode, press “Enter” key to confirm and exit the parameter setting menu.
- 2) Press “Tran” key to enter into transient operation.
- 3) Use “↑”, “↓” keys to select the parameter.
- 4) Use Entry keys or use the knob together with “◀”, “▶” keys to set values for LevelL, LevelH, TimeL, TimeH, TimeR, and TimeF. Use Entry keys or knob to set Mode value and set State to On.
- 5) Press “Cancel” key to exit the transient operation menu.
- 6) Press “On/Off” key to turn on the load.
- 7) If it is the pulsed transient operation or the toggled transient operation, one trigger occurs when pressing “Shift”+“0Trigger” keys or the signal at the trigger input terminal (TRIG IN) is low level.

5.7.1. Continuous Transient Operation

In continuous operation, the load periodically switches between high/low levels. The relevant parameters such as low level (LevelL), high level (LevelH), low level time (TimeL), high level time (TimeH), time for rising edge (TimeR), time for falling edge (TimeF).

Example: Set the load voltage value to periodically switch between 1V and 5V; set the time for rising edge (TimeR) to 10ms; set high level time (TimeH) to 200ms; set time for falling edge (TimeF) to 20ms; set low level time (TimeL) to 400ms, and the load is in continuous transient operation. The operating procedures are shown as below:

Procedures /// Operation Descriptions /// Display

1 /// Press “V-set” key to select CVH mode, press “Cancel” key to exit the parameter setting menu. /// CVH 04.000V

2 /// Press “Tran” key to enter into transient operation. /// STATE 0OFF

3 /// Use Entry keys or use the knob together with “◀”, “▶” keys to set State value to “1 On”, press “Enter” key to confirm. /// STATE 1ON

4 /// Use Entry keys or use the knob to set Mode value to “Cont”, press “Enter” key to confirm. /// MODE 0Cont

5 /// Use Entry keys or use the knob together with “◀”, “▶” keys to set LevelL to 1, press “Enter” key to confirm. /// LEVELL 01.000V



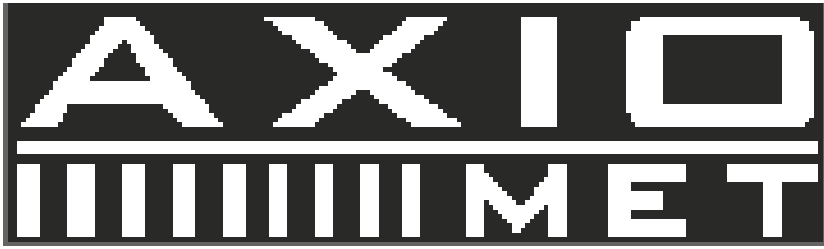

- 6 /// Use Entry keys or use the knob together with “◀”, “▶” keys to set LevelH to 5, press “Enter” key to confirm. /// LEVELH 05.000V
- 7 /// Use Entry keys or use the knob together with “◀”, “▶” keys to set TimeL to 400ms, press “Enter” key to confirm. /// TIMEL 400.00M
- 8 /// Use Entry keys or use the knob together with “◀”, “▶” keys to set TimeH to 200ms, press “Enter” key to confirm. /// TIMEH 200.00M
- 9 /// Use Entry keys or use the knob together with “◀”, “▶” keys to set TimeR to 10ms, press “Enter” key to confirm. /// TIMER 010.00ms
- 10 /// Use Entry keys or use the knob together with “◀”, “▶” keys to set TimeF to 20ms, press “Enter” key to confirm. /// TIMER 020.00ms
- 11 /// Press “Cancel” key to exit the transient operation menu. ///
- 12 /// Press “On/Off” key to turn on the load. ///

For the above operating procedures, the corresponding SCPI commands should be:

MODE CVH ; Sets the mode
TRAN ON ; Enables the transient operation
VOLT:LLEV 1 ; Sets a value to low level
VOLT:HLEV 5 ; Sets a value to high level
TRAN:LTIME 0.400 ; Sets the low level time to 400ms
TRAN:HTIME 0.200 ; Sets the high level time to 200ms
TRAN:RTIME 0.025 ; Sets the time for rising edge to 25ms
TRAN:FTIMR 0.025 ; Sets the time for falling edge to 25ms
TRAN:MODE CONT ; Selects the continuous transient operation
INPUT ON ; Turns on the load

5.7.2. Pulsed Transient Operation

Example: Assume that the load is in external triggering mode, set the load current value to periodically switch between 1A and 5A; set the time for rising edge (TimeR) to 10ms; set high level time (TimeH) to 200ms; set time for falling edge (TimeF) to 10ms; the load is in pulsed transient operation, and a trigger occurs at this time.

Procedures /// Operation Descriptions /// Display

- 1 /// Press “I-set” key to select CCL mode, press “Cancel” key to exit the parameter setting menu. /// CCL 04.000A
- 2 /// Press “Tran” key to enter into transient operation. /// STATE 1OFF
- 3 /// Use Entry keys or use the knob to set State value to “1 On”, press “Enter” key to confirm. /// STATE 1ON
- 4 /// Use Entry keys or use the knob to set Mode value to “Puls”, press “Enter” key to confirm. /// MODE 1PULS
/// ///
- 5 /// Use Entry keys or use the knob together with “◀”, “▶” keys to set LevelL to 1, press “Enter” key to





confirm. /// LEVELL 01.000V

6 /// Use Entry keys or use the knob together with “◀”, “▶” keys to set LevelH to 5, press “Enter” key to confirm. /// LEVELL 05.000V

7 /// Use Entry keys or use the knob together with “◀”, “▶” keys to set TimeH to 200ms, press “Enter” key to confirm. /// TIMEH 200.00M

8 /// Use Entry keys or use the knob together with “◀”, “▶” keys to set TimeR to 10ms, press “Enter” key to confirm. /// TIMER 040.00M

9 /// Use Entry keys or use the knob together with “◀”, “▶” keys to set TimeF to 10ms, press “Enter” key to confirm. /// TIMEF 040.00M

10 /// Press “Cancel” key to exit the transient operation menu. ///

11 /// Press “On/Off” key to turn on the load. ///

For the above operating procedures, the corresponding SCPI commands should be:

MODE CCH ; Sets the mode

TRAN ON ; Enables the transient operation

CURR:LLEV 1 ; Sets a value to low level

CURR:HLEV 5 ; Sets a value to high level

TRAN:HTIME 0. 200 ; Sets the high level time to 200ms

TRAN:RTIME 0.00025 ; Sets the time for rising edge to 250ms

TRAN:FTIME 0.00025 ; Sets the time for falling edge to 250ms

TRAN:MODE PULS ; Selects the pulsed transient operation

INPUT ON ; Turns on the load

Trig ; One trigger occurs

5.7.3. Toggled Transient Operation

Example: Assume that the load is in external triggering mode, set the load resistance value to periodically switch between 200Ω and 500Ω; set the time for rising edge (TimeR) to 10ms; set time for falling edge (TimeF) to 10ms; the load is in toggled transient operation, and a trigger occurs at this time.

Procedures /// Operation Descriptions /// Display

1 /// Press “R-set” key to select CRH mode, press “Enter” key to confirm and exit the parameter setting menu. /// VH CRH 100.000R

2 /// Press “Tran” key to enter into transient operation. /// STATE 1OFF

3 /// Use the knob to set State value to “1 On”, press “Enter” key to confirm. /// STATE 1ON

4 /// Use the knob to set Mode value to “Togg”, press “Enter” key to confirm. /// MODE 2Togg

5 /// Use the knob together with “◀”, “▶” keys to set LevelL to 200, press “Enter” key to confirm. /// LEVELL 200.00R

6 /// Use the knob together with “◀”, “▶” keys to set LevelH to 500, press “Enter” key to confirm. /// LEVELH 500.00R

7 /// Use the knob together with “◀”, “▶” keys to set TimeR to 10ms, press “Enter” key to confirm. /// TIMER 010.00M





- 8 /// Use the knob together with “◀”, “▶” keys to set TimeF to 10ms, press “Enter” key to confirm. /// TIMEF 040.00M
- 9 /// Press “Cancel” key to exit the transient operation menu. ///
- 10 /// Press “On/Off” key to turn on the load. ///

5.8. Sequence (List) Operation

5.8.0.

After sequence editing, the operating procedures for enabling and disabling sequence operation are shown as below:

- 1) Press “List” key to enter into sequence operation menu.
- 2) Use Entry keys or the knob to set sequence State to On, and press “Enter” key to confirm.
- 3) Use Entry keys or the knob together with “↑”, “↓” keys to set list number (No.), and press “Enter” key to confirm.
- 4) Press “Cancel” key to exit sequence operation menu.
- 5) Press “Shift”+“4Start” keys to activate sequence operation.
- 6) Press “Shift”+“5Stop” keys to stop sequence operation.

The operating procedures for sequence operation are shown as below:

- 1) Press “List” key to enter into sequence operation menu.
- 2) Use Entry keys or the knob to set sequence State to On, and press “Enter” key to confirm.
- 3) Use Entry keys or knob to select list number (No.). Press “Enter” key to confirm and recall the sequency in EEPROM assigned by the sequence number.
- 4) Use “↓” key to select list memo (Memo).
- 5) Use knob and “◀”, “▶” keys to edit memo (max. 10 characters).
- 6) Use “↓” key to select sequence data (Data:<New/Edit>). Use “◀”, “▶” keys keys or knob to select New or Edit operation.
- 7) Select “New” operation, and press “Enter” key to enter into data clear screen. Use the knob to select “Yes” and press “Enter” key to confirm, the data is cleared and meanwhile step edit screen appears. Use “▶” key or knob to select “No”, press “Enter” key to confirm, in the meantime the load returns to sequence (list) test menu.
- 8) Select “Edit” operation, and press “Enter” key to enter into step edit screen.
- 9) Use “↑”, “↓” keys to select parameters.
- 10) Use Entry keys or use the knob together with “◀”, “▶” keys to input set value; press “Enter” key to confirm and enter into the next step.
- 11) If it is needed to modify one step, use “↑”, “↓” keys to select this step. The setting operations for this step are the same as the operating procedure 9.
- 12) If it is needed to add one step to the last step, use “↓” key to select the new step. The setting operations for this new step are the same as the operating procedure 9.
- 13) If it is needed to insert one step above an edited step, use “↑”, “↓” keys to select this edited step. The





LCD display doesn't flash at this time, and press "Shift"+"7Insert" keys to insert a new step. The setting operations for this new step are the same as the operating procedure 9.

14) If it is needed to delete an edited step, use "↑", "↓" keys to select this step. The LCD display doesn't flash at this time, and press "Shift"+"8Delete" keys to delete. If there is only one step exists, it will exit the step edit screen.

15) Press "Cancel" key to exit step edit screen, and save the sequence data in EEPROM assigned by the sequence number.

16) Use "↓" key to select the cycle times (Count); use Entry keys or the knob together with "◀", "▶" keys to input set value. Press "Enter" key to confirm and save the cycle times (Count) in EEPROM assigned by the sequence number.

17) Use "↓" key to select "Chain"; use Entry keys (the "Chain" is OFF when the Entry key exceeds 7) or the knob to input the set value. Press "Enter" key to confirm and save the chain value in EEPROM assigned by the sequence number.

18) Press "Cancel" key to exit sequence operation menu.

19) Press "Shift"+"4Start" keys to activate sequence operation.

20) Press "Shift"+"5Stop" keys to stop sequence operation.

5.8.1. Sequence (List) Editing

Example: Edit a new sequence. The sequence number is 0; the sequence Memo is Test Power; the sequence steps: step1: CCL, 1A, 1s; step2: CCH, 2A, 1s; step3: CVH, 1V, 1s; step4: CRL, 1Ω, 1s; step5: CRH, 200Ω, 1s; the cycle times (Count) for sequence operation is 5; disabling the sequence chain; starting sequence operation; stopping sequence operation.

Procedures /// Operation Descriptions /// Display

1 /// Press "List" key to enter into sequence operation menu. /// STATE 0 OFF

2 /// Use Entry keys or the knob to set sequence State to On, and press "Enter" key to confirm. /// STATE 0 ON

3 /// Use Entry keys or knob to set list number (No.) to 0. Press "Enter" key to confirm (recall the sequence in EEPROM assigned by the sequence number). /// NO. 0

4 /// Use "↓", "↓" keys to select list memo (Memo). /// MEMO Test P

5 /// Rotate the knob to select the letter "T". /// MEMO Test P

6 /// Use "▶" key to move the cursor to the right. /// MEMO Test P

7 /// Rotate the knob to select the letter "e". /// MEMO Test Power

8 /// Set Memo to "Test Power" according to step5 and step6 operations. Press "Enter" key to confirm. /// MEMO Test Power

9 /// Use "↑", "↓" keys to select Data. /// DATA 0 New

10 /// Use the knob to select New, and "Enter" key to confirm. /// DATA 0 New

11 /// Use the knob to select "Yes" and press "Enter" key to confirm, the data is cleared and meanwhile step edit screen appears. /// CLEAR 1 YES

12 /// Edit the step1: CCL, 1A, 1s. Use "↑", "↓" keys to select time set value. Use Entry keys or the knob





together with “◀”, “▶” keys to input time to 1s, and press “Enter” key to confirm. /// NO 00.

13 /// Use “↑”, “↓” keys to select the basic mode. Use Entry keys or the knob to select operating mode to CCL, and press “Enter” key to confirm. /// MODE CCL

14 /// Use “↑”, “↓” keys to select the set value. Use Entry keys or the knob together with “◀”, “▶” keys to input the current value to 1A, and press “Enter” key to confirm. /// LEVEL 01.000A

15 /// Use “↑”, “↓” keys to select the set time. Use Entry keys or the knob together with “◀”, “▶” keys to input the time value to 1s, and press “Enter” key to confirm. /// DELAY 01.000S

16 /// Repeat the procedures 12 to 14 to set the rest four steps. ///

17 /// The five sequence steps have been edited, and there is no need to edit the step6. Press “Cancel” key to exit step edit screen and save the sequence data in EEPROM assigned by the sequence number. ///

18 /// Use “↑”, “↓” keys to select “Count”. use Entry keys or the knob together with “◀”, “▶” keys to input “5”. Press “Enter” key to confirm and save the Count value in EEPROM assigned by the sequence number. ///

/// SAVE

19 /// Use “↑”, “↓” keys to select “Chain”. use Entry keys (the “Chain” is OFF when the Entry key exceeds 7) or the knob to input “Off”. Press “Enter” key to confirm and save the Chain value in EEPROM assigned by the sequence number. /// COUNT 0005

20 /// Press “Cancel” key to exit sequence operation menu and enter into the sequence operating screen. ///

/// CHAIN 0

21 /// Press “Shift”+“4Start” keys to activate sequence operation. ///

22 /// Press “Shift”+“5Stop” keys to stop sequence operation. ///

For the above operating procedures, the corresponding SCPI commands should be:

LIST:NUMBER 0 ; Recalls the sequence of the number 0

LIST:MEMO "Test Power" ; Sequence memo is "Test Power"

LIST:ADD CCL,1,1

LIST:ADD CCH,2,1

LIST:ADD CVH,1,1

LIST:ADD CRL,1,1

LIST:ADD CRH,200,1 ; The above 5 commands are sequence steps

LIST:SAVE ; Saves the sequence

LIST:COUNT 5 ; Cycle times for this sequence

LIST:CHAIN OFF ; Disables the chained sequence

LIST ON ; Activates sequence operation

LIST OFF ; Stops sequence operation

5.8.2. Modifying, Adding, Inserting, Deleting the Sequence (List)

Exampe: Based on the example in 5.8.1 section, the step1: modify the time to 2s. Add “CCH, 5A, 1s” to the last step. Insert “CRL, 1Ω, 10s” at step3. Delete step2. The sequence is chained to itself to realize the continuous execution





Procedures /// Operation Descriptions /// Display

- 1 /// Press "List" key to enter into sequence operation menu. /// STATE 1 On
- 2 /// Use "↑", "↓" keys to select Data:<New/Edit>. /// DATA 0 New
- 3 /// Use the knob to select Edit, press "Enter" to confirm and enter into the step edit screen. /// DATA 1 Edit
- 4 /// Use "▶" key to select time parameter and the time set value. /// NO 00
- 5 /// Use Entry keys or the knob together with "◀", "▶" keys to input the time to 2s, and press "Enter" key to confirm. /// DELAY 02.000S
- 6 /// Use "↑", "↓" key to select the last new step (Step6). /// NO 05
- 7 /// Add a new step: CCH, 5A, 1s. Use Entry keys or the knob together with "◀", "▶" keys to input time to 1s, and press "Enter" key to confirm. /// MODE CCH
- 8 /// Use the knob to select operating mode to CCH, and press "Enter" key to confirm. /// LEVEL 05.000A
- 9 /// Use Entry keys or the knob together with "◀", "▶" keys to input the current value to 5A. Press "Enter" key to confirm and enter into the next operation. /// DELAY 01.000S
- 10 /// Use "↑", "↓" keys to select the step3. /// NO 02
- 11 /// Press "Shift"+"7Insert" keys to insert a new step at step3. /// NO 02
- 12 /// Insert a new step: CRL, 1Ω, 10s at step3. The setting operations for this new step are the same as the operating procedures7 to 9. /// NO 02
- 13 /// Use "↑", "↓" keys to select the step2. /// NO 01
- 14 /// Press "Shift"+"8Delete" keys to delete the step2. /// NO 01
- 15 /// Press "Cancel" keys to exit the step edit screen and save the sequence data in EEPROM assigned by the sequence number. /// DATA 1 Edit
- 16 /// Use "↑", "↓" keys to select chain. /// CHAIN Off
- 17 /// Use Entry keys or the knob to input 0 (it is chained o itself to realize continuous execution). Press "Enter" key to confirm and save the Chain value in EEPROM assigned by the sequence number. /// CHAIN 0"
- 18 /// Press "Cancel" key to exit sequence operation menu. ///

5.8.3. Starting/Stopping the Sequence (List)

Example: Start the No.0 sequence, and stop the active sequence operation.

Procedures /// Operation Descriptions /// Display

- 1 /// Press "List" key to enter into sequence operation menu. /// STATE 1 On
- 2 /// Use "↓" key to select No..Use Entry keys or knob to set the sequence number (No.) to 0, and press "Enter" key to confirm (recall the sequence in EEPROM assigned by the sequence number). /// No. 0
- 3 /// Press "Cancel" key to exit sequence operation menu. ///
- 4 /// Press "Shift"+"4Start" keys to activate sequence operation. (the other operations will be active only when the sequency operation is disabled.) ///
- 5 /// Press "Shift"+"5Stop" keys to stop sequence operation. ///





For the above operating procedures, the corresponding SCPI commands should be:

LIST:NUMBER 0 ; Recalls the sequence of the number 0

LIST ON ; Activates sequence operation

LIST OFF ; Stops sequence operation

5.9. Battery Discharge Operation

Battery discharge operation diagram:

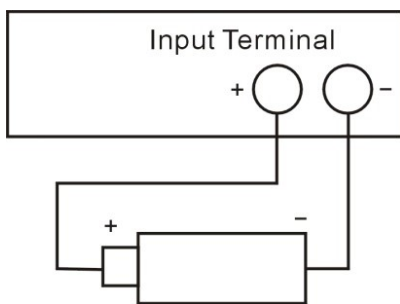

The operating procedures for battery discharge operation are shown as below:

- 1) Press "On/Off" key to turn off the load, and connect the tested battery correctly.
- 2) Press "Battery" key, set the State to On and enter into battery discharge operation screen.
- 3) Use "↑", "↓" keys to select parameters. Use Entry keys or the knob together with "◀", "▶" keys to input State, termination voltage value, termination current value and discharge current value. Press "Enter" key to confirm.
- 4) Press "Cancel" key to exit the battery discharge parameters edit screen.
- 5) Press "On/Off" key to turn on the load, and start battery discharge operation.
- 6) Press "On/Off" key to turn off the load, and stop battery discharge operation.
- 7) Press "Cancel" key to clear the discharged time and discharged capacity of the battery.
- 8) Press the other function keys or "Cancel" key to exit the battery discharge operation.

Example: Enter into the battery discharge operation; set the termination voltage to 15V, and the discharge current to 3A; turn on the load, and start the battery discharge operation; turn off the load and stop the battery discharge operation; clear the discharged time and discharged capacity of the battery; exit the battery discharge operation.

Procedures /// Operation Descriptions /// Display

1 /// Press "On/Off" key to turn off the load, and connect the tested battery correctly. ///

2 /// Press "Battery" key to enter into battery discharge capacity parameters edit screen. /// STATE 0 Off

3 /// Use Entry keys or the knob to set battery State to On, and press "Enter" key to confirm. /// STATE 1 On





- 4 /// Use “↑”, “↓” keys to select parameters to input termination voltage (Mini Volt). Use Entry keys or the knob together with “◀”, “▶” keys to input termination voltage to 15V, and press “Enter” key to confirm. /// MIN VO 15.000V
- 5 /// Use “↑”, “↓” keys to select parameters to input termination current (Mini Curren). Use Entry keys or the knob together with “◀”, “▶” keys to input termination current to 1A, and press “Enter” key to confirm. /// IOFF P 01.000A
- 6 /// Use Entry keys or the knob together with “◀”, “▶” keys to input discharge current to 3A, and press “Enter” key to confirm. /// DISCUR 3.000A
- 7 /// Press “Cancel” key to exit the battery discharge parameters edit screen. ///
- 8 /// Press “On/Off” key to turn on the load, and start battery discharge operation. ///
- 9 /// Press “On/Off” key to turn off the load, and stop battery discharge operation. ///
- 10 /// Press “Cancel” key to clear the discharged time and discharged capacity of the battery. ///
- 11 /// Press mode hotkey to exit the battery discharge operation ///

For the above operating procedures, the corresponding SCPI commands should be:

INPUT OFF ; Turns off the load

BATTERY ON ; Activates the battery discharge operation screen

BATT:VOLT:OFF 15 ; Sets termination voltage to 15V

BATT:DISC:CURR 3 ; Sets termination current to 3A

INPUT ON ; Turns on the load, and start battery discharge operation

INPUT OFF ; Turns off the load, and stop battery discharge operation

BATTERY OFF ; Exits the battery discharge operation

5.10. Saving and Recalling

The operating procedures for saving and recalling operation are shown as below:

- 1) Press “Shift”+“1Store” keys to enter into the saving menu, or press “Shift”+“2Recall” keys to enter into the recalling menu.
- 2) Press Entry keys or the knob to select saving or recalling position.
- 3) Press “Enter” key to confirm and exit the saving or recalling menu. If the saving is selected, the values of List2-1 parameters will be saved in the specified location in EEPROM; if the recalling is selected, the values of List2-1 parameters should be the values saved in specified location in EEPROM.

Example1: Set the mode to CCL; set the current value to 2A; turn on the load; save the settings in location 0 in EEPROM; the next time the load is turned on, these settings will become the power-on settings.

Procedures /// Operation Descriptions /// Display

- 1 /// Set the mode to CCL, set the current value to 2A; turn on the load (please refer to 4.5.1 section for detailed operations). ///
- 2 /// Press “Shift”+“1Store” keys to enter into the saving menu. /// SAVE 0
- 3 /// Press Entry keys or the knob to select the location 0 for saving. /// SAVE 0
- 4 /// Press “Enter” key to confirm. ///





For the above operating procedures, the corresponding SCPI commands should be:

MODE CCL ; Sets the load to CCL status

CURR 2 ; Sets the current value to 2A

*SAV 0 ; Saves the present settings in location 0 in EEPROM

Example2: Based on the above example, set the mode to CVH; set the voltage value to 40V; recall the values saved in location0 in EEPROM. The detailed operations are shown as below:

Procedures /// Operation Descriptions /// Display

1 /// Set the mode to CVH, set the voltage value to 40V (please refer to 4.5.2 section for detailed operations).

///

2 /// Press “Shift”+“2Recall”keys to enter into the recalling menu. /// RECALL 0

3 /// Press Entry keys or the knob to select the recalled location 0. /// RECALL 0

4 /// Press “Enter” key to confirm. ///

For the above operating procedures, the corresponding SCPI commands should be:

MODE CVH ; Sets the CVH mode

VOLT 40 ; Sets the voltage value to 40V

*RCL 0 ; Recalls the values saved in location 0 in EEPROM

5.11. Clear Protection Settings

The operating procedures for clear protection settings are shown as below:

- 1) Eliminate the reason that causes the protection status.
- 2) Press “Cancel” keys.

Example1: Clear RV protection of the load. The detailed operations are shown as below:

Procedures /// Operation Descriptions /// Display

1 /// Connect the power supply to the load again. ///

2 /// Long-press “Cancel” key. ///

For the above operating procedures, the corresponding SCPI commands should be:

INP:PROT:CLE ; Clears the protection status

5.12. Triggered Operation

When the triggering mode is EXTERNAL, the triggered operations are shown as below:

- 1) Set trigger object (please see 3.8 section for detailed introduction).
- 2) Press “Shift”+“0Trigger” keys or trigger terminal (TRIG IN) to receive low TTL level, and a trigger occurs.

Example: Select “List” for the trigger function to trigger a sequence operation. The sequence is the one mentioned in Example in 5.8.1 section. The detailed operations are shown as below:





Procedures Operation Descriptions

- 1 Select "List" in main menu for the trigger function (please see 5.14.6 section for detailed introduction).
- 2 Enter to List operation screen (please see 5.8 section for detailed introduction).
- 3 Press "Shift"+"0Trigger" keys or trigger terminal (TRIG IN) to receive low TTL level. The load's input will change accordingly when the sequence parameters are changed. Pressing "Shift"+"0Trigger" keys has the same effect as pressing "Shift"+"4Start" keys at this time.

For the above operating procedures, the corresponding SCPI commands should be:

TRIG:FUNC LIST ; Selects "List" for trigger function

TRIG ; A trigger occurs

5.13. Main Menu

5.13.0.

The operating procedures for the main menu are shown as below:

- 1) Press "Menu" key to enter into the main menu.
- 2) Use Entry keys or the knob to select the menu item.
- 3) Use "↑", "↓" keys to select the parameter; or use Entry keys or the knob together with "◀", "▶" keys to input set value. Press "Cancel" key to exit modifying the parameter or exit the main menu.
- 4) Press "Enter" key to confirm.
- 5) Press "Cancel" key to exit the main menu.

5.13.1. Loading Default Values

Example: Load the default values. The detailed operations are shown as below:

Procedures /// Operation Descriptions /// Display

1 /// Press "Menu" key to enter into the selectable menu. /// Menu 0 SYST

2 /// Use Entry keys or the knob to select "1 Config", press "Enter" key to confirm and enter into Config. /// Menu 1 CONF

3 /// Use "↑", "↓" keys to select the parameter menu "Load Defa". Use Entry key or the knob to select the parameter "Yes". /// LOAD D 1Yes

4 /// Press "Enter" key to confirm and return. ///

5.13.2. Short Circuit Operation

Example: Short circuit operation in CVL mode. The detailed operations are shown as below:

Procedures /// Operation Descriptions /// Display

1 /// Press "Menu" key to enter into the selectable menu. /// Menu 0 SYST

2 /// Use Entry keys or the knob to select "0 System Set", press "Enter" key to confirm and enter into System Set. /// CC Set 0 Low

3 /// Use "↑", "↓" keys to select the menu item "Short". /// SHORT 0 Off

4 /// Use the knob to set the "Short" to On, and press "Enter" key to confirm. /// SHORT 1On





5 /// Press “Cancel” key to exit the main menu. ///

6 /// Press “V-set” key to select CVL mode, press “Enter” key to confirm and exit the mode selection and parameter setting menu. ///

7 /// Press “On/Off” key to turn on the load. ///

For the above operating procedures, the corresponding SCPI commands should be:

INPUT:SHORT ON ; Sets the load to short circuit

MODE CVL ; Sets the mode

INPUT ON ; Turns on the load

5.13.3. Von Point/Von Latch

Example: Set the Von Latch to Off; set Von Point to 1V; turn on the load; This example implements the automatic on/off of the load’s input, which simplifies the test operations greatly. The detailed operations are shown as below:

Procedures /// Operation Descriptions /// Display

1 /// Press “Menu” key to enter into the selectable menu. /// MENU 0 SYST

2 /// Use Entry keys or the knob to select “0 System Set”, press “Enter” key to confirm and enter into System Set. /// CC SET 0 LOW

3 /// Use “↑”, “↓”keys to select the menu item “Von Latch”. Use the knob to select the parameter “Off”, and press “Enter” key to confirm. /// VON LA 0 Off

4 /// Use “↑”, “↓”keys to select the menu item “Von Point”. Use Entry keys or the knob together with “◀”, “▶” keys to input the voltage value to 1V, and press “Enter” key to confirm. /// VON PO 01 .000V

5 /// Press “Cancel” key to exit the main menu. ///

6 /// Press “On/Off” key to turn on the load. ///

For the above operating procedures, the corresponding SCPI commands should be:

INP:VOLT:ON:LATCH OFF ; Disables the Von Latch

INP:VOLT:ON 1 ; Sets the Von voltage point to 1V

INPUT ON ; Turns on the load

5.13.4. Current Limit in CV Mode

Example: Set the load to CVL mode; set the voltage value to 2V; set the current limit value in CV mode (CV Curr Limit) to 20A; turn on the load. The detailed operations are shown as below:

Procedures /// Operation Descriptions /// Display

1 /// Set the mode to CVL, set the voltage value to 2V (please refer to 4.5.2 section for detailed operations). ///

2 /// Press “Menu” key to enter into the selectable menu. /// MENU 0 SYST

3 /// Use Entry keys or the knob to select “0 System Set”, press “Enter” key to confirm and enter into System Set. /// CC SET 0 LOW

4 /// Use “↑”, “↓”keys to select the menu item “CV Curr L”. /// CV CUR 120.000A

5 /// Use Entry keys or the knob together with “◀”, “▶” keys to input the current value to 20.000A, and press





“Enter” key to confirm. /// CV CUR 20.000A

6 /// Press “Cancel” key to exit the main menu. ///

7 /// Press “On/Off” key to turn on the load. ///

For the above operating procedures, the corresponding SCPI commands should be:

MODE CVL ; Sets the mode

VOLT 2 ; Sets the volgate value to 2V

CV:CURR:LIM 20 ; Sets the current limit value to 20A in CV mode

INPUT ON ; Turns on the load

5.13.5. Current Rise/Fall Rate in CC Mode

Example: Set the load to CCH mode, set the current value to 2A; set the current rise rate (Curr Rise Rate) in CC mode to 0.002A/us; set the current fall rate (Curr Fall Rate) in CC mode to 0.005A/us. The detailed operations are shown as below:

Procedures /// Operation Descriptions /// Display

1 /// Set the mode to CCH,; set the current value to 2A (please refer to 4.5.1 section for detailed operations).

///

2 /// Press “Menu” key to enter into the selectable menu. /// MENU 0 SYST

3 /// Use Entry keys or the knob to select “0 System Set”, press “Enter” key to confirm and enter into System Set. /// CC SET 0 LOW

4 /// Use “↑”, “↓”keys to select the menu item “Curr Rise”. Use Entry keys or the knob together with “◀”, “▶” keys to input the current rise rate to 0.002A/us, and press “Enter” key to confirm. /// CURR R 0.002A/us

5 /// Use “↑”, “↓” keys to select the menu item “Curr Fall”. Use Entry keys or the knob together with “◀”, “▶” keys to input the current fall rate to 0.005/us, and press “Enter” key to confirm. /// CURR F 0.005A/us

6 /// Press “Cancel” key to exit the main menu. ///

7 /// Press “On/Off” key to turn on the load. ///

For the above operating procedures, the corresponding SCPI commands should be:

MODE CCH ; Sets the mode

CURR 2 ; Sets the current value to 2A.

CURR:RISE:RATE 0.002 ; Sets the current rise rate in CC mode to 0.002A/us

CURR:FALL:RATE 0.005 ; Sets the current fall rate in CC mode to 0.005A/us

INPUT ON ; Turns on the load

INPUT OFF ; Turns off the load

5.13.6. Trigger Function Selection

Example: Select “Tran” in trigger function selection (Trig Function).

Procedures /// Operation Descriptions /// Display

1 /// Press “Menu” key to enter into the selectable menu. /// MENU 0 SYST

2 /// Use Entry keys or the knob to select “3 Trigger Set”, press “Enter” key to confirm and enter into Trigger Set. /// MENU 3 TRIG





3 /// Use “↑”, “↓” keys to select the menu item “Function”. Use Entry keys or the knob to select the parameter “Tran”, and press “Enter” key to confirm. /// Trig Func 0 Tran

4 /// Press “Cancel” key to exit the main menu. ///

For the above operating procedures, the corresponding SCPI commands should be:

TRIG:FUNC TRAN ; Selects transient operation (TRAN) for trigger function

5.13.7. Knob Function

Example: Enable the knob function.

Procedures /// Operation Descriptions /// Display

1 /// Press “Menu” key to enter into the selectable menu. /// MENU 0 SYST

2 /// Use Entry keys or the knob to select “1 Config”, press “Enter” key to confirm and enter into Config. /// MENU 1 CONF

3 /// Use “↑”, “↓” keys to select the menu item “Knob”. Use Entry keys or the knob to select the parameter “On”, and press “Enter” key to confirm. /// KNOB 1 On

4 /// Press “Cancel” key to exit the main menu. ///

5.13.8. Key Sound

Example: Enable the key sound.

Procedures /// Operation Descriptions /// Display

1 /// Press “Menu” key to enter into the selectable menu. /// MENU 0 SYST

2 /// Use Entry keys or the knob to select “1 Config”, press “Enter” key to confirm and enter into Config. /// MENU 1 CONF

3 /// Use “↑”, “↓” keys to select the menu item “Key Sound”. Use Entry keys or the knob to select the parameter “On”, and press “Enter” key to confirm. /// KEY SO 1On

4 /// Press “Cancel” key to exit the main menu. ///

5.13.9. Communication Interface

Example: Select RS232 interface; set the baud rate to 9600; set parity check to None; set data bit to 8; set stop bit to 2.

Procedures /// Operation Descriptions /// Display

1 /// Press “Menu” key to enter into the selectable menu. /// MENU 0 SYST

2 /// Use Entry keys or the knob to select “1 Config”, press “Enter” key to confirm and enter into Config. /// MENU 1 CONF

3 /// Use “↑”, “↓” keys to select the menu item “Baud Rate”. Use the knob or “◀”, “▶” keys to select the parameter “9600”, and press “Enter” key to confirm. /// BAUD R 2 9600

4 /// Use “↑”, “↓” keys to select the menu item “Parity Check”. Use the knob to select the parameter “None”, and press “Enter” key to confirm. /// PARITY 0 None





- 5 /// Use “↑”, “↓” keys to select the menu item “Data Bit”. Use the knob to select the parameter “8”, and press “Enter” key to confirm. /// DATA B 0 8bit
- 6 /// Use “↑”, “↓” keys to select the menu item “Stop Bit”. Use the knob to select the parameter “2”, and press “Enter” key to confirm. /// STOP B 1 2bit
- 7 /// Press “Cancel” key to exit the main menu. ///

6. Remote Programming Operation

6.0.

This Series Electronic Load supports both local operation and remote control. The previous chapter has introduced how to use the front panel keys and knobs to operate on the load. This chapter will introduce you to how to use the load from the remote controller. The similarities between local and remote programming will become apparent as you read this chapter. The intent of this chapter is to help users quickly become familiar with remote programming operations. Programming examples given in this chapter use the SCPI commands in their simplest form. Please refer to the “Electronic Load SCPI Programming Guide” for detailed introduction of all SCPI commands.

6.1. Communication Interface

RS232 interface is standard. Use the cable shipped with the load to connect the load to a computer correctly. Set the baud rate, parity, data bit, and stop bit parameters. Set the same parameters in the software on the computer, and input the right SCPI command to operate the load.

6.2. Remote Control Annunciators

There is a Rmt remote control annunciator on LCD. When the load receives the remote command (SYS-Tem:REMOte) via RS232 interface, the Rmt remote control annunciator turns on. In remote control status, all operations on the load are controlled by the remote controller; the front panel keypad and knob has no effect (except “Lock/Local” key). The R Rmt remote control annunciator turns off and the load returns to the local control after receiving the command to return to local control (e.g. :SYST:LOC). Or you can return the load to local control from remote control by long-pressing “Lock/Local” key.

6.3. Sending a Remote Command

You can use the computer to set operation mode and operation parameters remotely for the load.





6.4. Returning Data

The load can return the values of parameter settings, input voltage and current, as well as input power to computer. It can also return information relating to the internal operation and module identification. For example: the query command "MEAS:CURRE?" asks the load to return the actual input current at the Input binding posts. Please refer to "Electronic Load SCPI Programming Guide" for detailed information on using queries. The load stores the response to the query in an output buffer which will hold the information until it is read by the computer or is replaced with new information.

6.5. Remote Programming Commands

6.5.0.

The SCPI commands have many optional key words for the programmer. Getting familiar with these key words will help you to know the programming better. Most of the commands have a query syntax which allows the present parameter settings to be returned to the controller. Please refer to "Electronic Load SCPI Programming Guide" for details. The load's major functions can be programmed with a relatively few number of these commands. The following points are important to remember when you are remotely programming CC, CR, CV, and CP values.

6.5.1. Basic Operation Modes

The CC, CR, CV, and CP values can be programmed whether or not the associated mode is active. If the input is turned on, all of the applicable values will take effect at the input when the associated mode is selected.

6.5.2. Transient Levels

The transient CC, CV, or CR level must be set to a higher level than the respective low level, or the transient operation will be disabled.

6.5.3. Programmable Current Protection

When programmable current protection is enabled, and the programmed current limit and time delay are exceeded, the load's input will be turned off.

6.6. CC Mode Example

This example sets the current level to 0.5A, and then reads back the actual current value.

- 1) "INPUT OFF" ; Turns off the load's input
- 2) "MODE CCL" ; Selects the CCL mode
- 3) "CURR 0.5" ; Sets current value to 0.5A
- 4) "INPUT ON" ; Turns on the load's input
- 5) "MEAS:CURRE?" ; Measures the actual input current





6.7. CV Mode Example

This example presets the trigger voltage to 5V, and selects the external trigger source.

- 1) "INPUT OFF" ; Turns off the load's input
- 2) "MODE CVL" ; Selects the CV mode
- 3) "VOLT:TRIG 5" ; Presets the trigger voltage value to 5V
- 4) "TRIG:SOUR EXT" ; Selects the external input as the trigger source
- 5) "INPUT ON" ; Turns on the load's input

In this example, when the external trigger signal is received, the input voltage will be set to 5V.

6.8. CR Mode Example

This example sets the current protection limit to 3A, sets the time delay to 10s, sets the resistance level to 10 Ω , and reads back the computed power.

- 1) "INPUT OFF" ; Turns off the load's input
- 2) "MODE CRM" ; Selects the CRM mode
- 3) "CURR:PROT:LEV 3" ; Sets the current protection limit to 3A
- 4) "CURR:PROT:DEL 10" ; sets the time delay to 10s
- 5) "CURR:PROT:STAT ON" ; Activates the current protection
- 6) "RES 10" ; Sets the resistance level to 10 Ω
- 7) "INPUT ON" ; Turns on the load's input
- 8) "MEAS:POW?" ; Measures the input power level

6.9. Continuous Transient Operation Example

This example sets CV transient high/low levels, times for transient rising/falling edge, high/low level times, and parameters for transient operation.

- 1) "INPUT OFF" ; Turns off the load's input
- 2) "MODE CVH" ; Selects the CV mode
- 3) "VOLT:LLEV 0.5" ; Sets the transient low level to 0.5V
- 4) "VOLT:HLEV 1" ; Sets the transient high level to 1V
- 5) "TRAN:LTIM 0.010" ; Sets transient low level time to 10ms
- 6) "TRAN:HTIM 0.010" ; Sets transient high level time to 10ms
- 7) "TRAN:RTIM 0.010" ; Sets the time for transient rising edge to 10ms
- 8) "TRAN:FTIM 0.010" ; Sets the time for transient falling edge to 10ms
- 9) "TRAN:MODE CONT" ; Selects the continuous transient operation
- 10) "TRAN ON" ; Activates the transient operation
- 11) "INPUT ON" ; Turns on the load's input





6.10. Pulsed Transient Operation Example

This example selects CV pulsed transient operation, selects the bus as the trigger source, and sets a pulse width of 1ms.

- 1) "INPUT OFF" ; Turns off the load's input
- 2) "MODE CVH" ; Selects the CV mode
- 3) "TRIG:FUNC TRAN" ; Selects the transient for trigger function
- 4) "TRIG:SOUR BUS" ; Selects the bus as the trigger source
- 5) "VOLT:LLEV 0.5" ; Sets the transient low level to 0.5V
- 6) "VOLT:HLEV 1" ; Sets the transient high level to 1V
- 7) "TRAN:HTIM 0.001" ; Sets transient high level time to 1ms
- 8) "TRAN:RTIM 0.000250" ; Sets the time for transient rising edge to 250us
- 9) "TRAN:FTIM 0.000250" ; Sets the time for transient falling edge to 250us
- 10) "TRAN:MODE PULSE" ; Selects the pulsed transient operation
- 11) "TRAN ON" ; Activates the transient operation
- 12) "INPUT ON" ; Turns on the load's input
- 13) "*TRG" ; *TRG command generates a 1ms high-level pulse at the load's input

7. Auto Test Operation

7.1. Main Menu

Press $\square \square$ key to enter into main menu of Auto Test. Rotate knob to select menu. Press "Enter" key to enter into the function option on the cursor. Use "↑" key or "↓" key to turn over the LCD screen. At this time, press "↓" key to enter into the next level submenu. Press "Cancel" key to exit the menu setting.

Please see the list below for main menu content:

Trigger set

/// Function /// Trigger function: 0 input - input On/Off; 1 Level - recall trigger value; 2 List - enable List; 3 Tran - enable Tran

/// Source /// Trigger source selection: 0 External - external key trigger ("Shift"+"0Trigger"); 1 Pluse - TTL trigger on the rear panel; 2 Bus - the trigger source is *TRG command; 3 Hold - use the command "TRIGger:IMMediate" as trigger source

Auto Test

/// State /// Auto test state on/off

/// End Step /// End step (0-14)

/// Step /// Step selection (0-14)

/// Mode /// Mode setting

/// Level /// Setting value

/// Min /// Parameter limit minimum value





/// Max /// Parameter limit maximum value
/// Delay /// Test time

7.2. LCD Display Message

The LCD shows actual voltage, current, power and resistance levels. The second line shows test state and test steps.

7.3. Function Description

The load has auto test function. Users can set the test mode, setting value, limit value range, test time and end step. There are two trigger functions: auto trigger and external TTL trigger. In auto trigger mode, when the external input voltage is more than the Von Point, the trigger will be enabled and the load starts to test; When the external input voltage is less than the Voff Point, the load will enter into waiting status. In external TTL trigger mode, short the TTL TRIG IN terminal at the rear panel and the trigger will occur. It can realize that the multi-output power supply can be tested by more than one load simultaneously. The test has 15 steps, set step parameters, turn on auto test state, input trigger signal, then start to test. It will display steps, parameters and test state. If error occurs, the input will be turned off and remain at the actual step and display the measurement value, press “Cancel” key to clear the error status.

7.4. Local Operation

7.4.1. Single Power Supply Test

For example: to test 5V2A power bank, connect the load and start auto test.

Step /// Mode /// Setting value /// Min level /// Max level /// Description

0 /// CCL /// 00.000A /// 4.500V /// 5.500V /// Test the range of Voff point: 4.8V-5.5V

1 /// CCL /// 02.000A /// 4.500V /// 5.500V /// Test the range of Voff point with load 2A: 4.5V-5.5V

2 /// CVL /// 04.500V /// 01.000A /// 02.500A /// Test the load of 4.5V output:1.0A-2.5A

Detailed steps as below:

Procedures /// Operation Descriptions /// Display

1 /// Set the external trigger as the load's trigger mode; Set the load's Von point to 2.0V; Set the load's Voff point to 1.0V /// SOUTCE 0 EXTE; VON PO 02 .000V; VOFF P 01 .000V

2 /// Press key to enter into Auto Test menu. /// STATE 1 On

3 /// The indicator of is turned on after entering into Auto Test menu. /// STATE 1 On

4 /// Use Entry keys or the knob to set the State to On, and press “Enter” key to confirm. /// STATE 1 On

5 /// Use “↑”, “↓” keys to select the parameter end step. Use Entry keys or the knob together with “◀”, “▶” keys to input the end step to 2, and press “Enter” key to confirm. /// END ST 2

6 /// Use “↑”, “↓” keys to select the parameter step. Use Entry keys or the knob together with “◀”, “▶” keys





to input the step to 0, and press “Enter” key to confirm. (This is used for testing Voff point) /// STEP 0
7 /// Use “↑”, “↓” keys to select the parameter mode. Use Entry keys or the knob together with “◀”, “▶” keys to enter into CCL, and press “Enter” key to confirm. /// MODE 0 CCL
8 /// Use “↑”, “↓” keys to select the parameter setting level. Use Entry keys or the knob together with “◀”, “▶” keys to input the setting level to 0.000A, and press “Enter” key to confirm. /// LEVEL 00.000A
9 /// Use “↑”, “↓” keys to select the parameter limit minimum value. Use Entry keys or the knob together with “◀”, “▶” keys to input the minimum value to 4.800V, and press “Enter” key to confirm. /// MIN 04.800V
10 /// Use “↑”, “↓” keys to select the parameter limit maximum value. Use Entry keys or the knob together with “◀”, “▶” keys to input the maximum value to 5.500V, and press “Enter” key to confirm. /// MAX 05.500V
11 /// Use “↑”, “↓” keys to select the parameter test time. Use Entry keys or the knob together with “◀”, “▶” keys to input the test time to 1s, and press “Enter” key to confirm. /// DELAY 00001s
12 /// Use “↑”, “↓” keys to select the parameter step. Use Entry keys or the knob together with “◀”, “▶” keys to input the step to 1, and press “Enter” key to confirm. (This is used for testing the voltage with load 2A) /// STEP 1
13 /// Use “↑”, “↓” keys to select the parameter mode. Use Entry keys or the knob together with “◀”, “▶” keys to enter into CCL, and press “Enter” key to confirm. /// MODE 0 CCL
14 /// Use “↑”, “↓” keys to select the parameter setting level. Use Entry keys or the knob together with “◀”, “▶” keys to input the setting level to 2.000A, and press “Enter” key to confirm. /// LEVEL 02.000A
15 /// Use “↑”, “↓” keys to select the parameter limit minimum value. Use Entry keys or the knob together with “◀”, “▶” keys to input the minimum value to 4.500V, and press “Enter” key to confirm. /// MIN 04.500V
16 /// Use “↑”, “↓” keys to select the parameter limit maximum value. Use Entry keys or the knob together with “◀”, “▶” keys to input the maximum value to 5.500V, and press “Enter” key to confirm. /// MAX 05.500V
17 /// Use “↑”, “↓” keys to select the parameter test time. Use Entry keys or the knob together with “◀”, “▶” keys to input the test time to 2s, and press “Enter” key to confirm. /// DELAY 00002s
18 /// Use “↑”, “↓” keys to select the parameter step. Use Entry keys or the knob together with “◀”, “▶” keys to input the step to 2, and press “Enter” key to confirm. (This is used for testing the output current of constant voltage 4.5V) /// STEP 2
19 /// Use “↑”, “↓” keys to select the parameter mode. Use Entry keys or the knob together with “◀”, “▶” keys to enter into CVL, and press “Enter” key to confirm. /// MODE 2 CVL
20 /// Use “↑”, “↓” keys to select the parameter setting level. Use Entry keys or the knob together with “◀”, “▶” keys to input the setting level to 4.500V, and press “Enter” key to confirm. /// LEVEL 04.500V
21 /// Use “↑”, “↓” keys to select the parameter limit minimum value. Use Entry keys or the knob together with “◀”, “▶” keys to input the minimum value to 1.000A, and press “Enter” key to confirm. /// MIN 01.000A
22 /// Use “↑”, “↓” keys to select the parameter limit maximum value. Use Entry keys or the knob together with “◀”, “▶” keys to input the maximum value to 2.500A, and press “Enter” key to confirm. /// MAX 02.500A
23 /// Use “↑”, “↓” keys to select the parameter test time. Use Entry keys or the knob together with “◀”, “▶”



keys to input the test time to 2s, and press “Enter” key to confirm. /// DELAY 00002s
 24 /// Press “Cancel” key to exit auto test parameter edit interface and enter into auto test waiting interface.
 ///

After completing all the above steps, it can enable auto test only by connecting power bank to the load’s input terminal, doesn’t need keys operation.

7.4.2. Multi-output Power Supply Test

For example: to test 75W, 5V/6A,+15V/2.3A,-15V/0.5A multi-output power supply, connect the power supply to load following the fig.7.1.

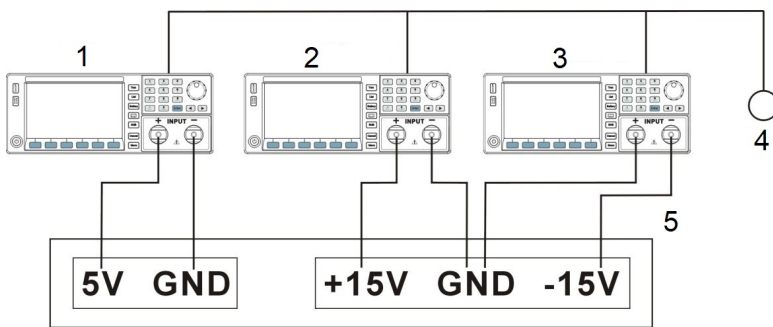

Fig. 7-1

- 1 - Load A
- 2 - Load B
- 3 - Load C
- 4 - Trigger
- 5 - Power Supply

Test step:

Step	Load number	Mode	Level	Min	Max	Delay	Description
0	A	CCL	0.000A	15.000V	16.000V	1s	Test Voff Point
0	B	CCL	0.000A	15.000V	16.000V	1s	Test Voff Point
0	C	CCL	0.000A	15.000V	16.000V	1s	Test Voff Point
1	A	CCL	2.300A	14.500V	16.000V	2s	Test Von Point in CC
1	B	CCL	2.300A	14.500V	16.000V	2s	Test Von Point in CC
1	C	CCL	0.500A	14.200V	16.000V	2s	Test Von Point in CC
2	A	CVL	5.000V	6.000A	10.000A	2s	Test Von Point in CV
2	B	CVL	15.000V	2.300A	5.400A	2s	Test Von Point in CV
2	C	CVL	14.500V	0.400A	0.600A	2s	Test Von Point in CV



Detailed operation steps as below:

1) Load A, to test 5V/6A

Procedures /// Operation Descriptions /// Display

- 1 /// Set the external TTL trigger as the load's trigger mode; Set the load's Von point to 2.0V; Set the load's Voff point to 1.0V /// SOURCE 1 Pulse; VON PO 02 .000V; VOFF P 01 .000V
 - 2 /// Press key to enter into Auto Test menu /// STATE 1 ON
 - 3 /// The indicator of is turned on after entering into Auto Test menu. /// STATE 1 ON
 - 4 /// Use Entry keys or the knob to set the State to On, and press "Enter" key to confirm. /// STATE 1 ON
 - 5 /// Use "↑", "↓" keys to select the parameter end step. Use Entry keys or the knob together with "◀", "▶" keys to input the end step to 2, and press "Enter" key to confirm. /// END ST 2
 - 6 /// Please refer to 6.4.1 operation steps, and set parameters according to table 4-A.
 - 7 /// Press "Cancel" key to exit auto test parameter edit interface and enter into auto test waiting interface.
- Table 7-A: 5V/6A parameter setting

Step	Mode	Level	Min	Max	Delay
0	CCL	0.000A	5.000V	5.500V	1s
1	CCL	6.000A	4.800V	5.500V	2s
2	CVL	5.000V	6.000A	10.000A	2s

2) Load B, to test +15V/2.3A

Procedures /// Operation Descriptions /// Display

- 1 /// Set the external TTL trigger as the load's trigger mode. /// SOURCE 1 Pulse
- 2 /// Press key to enter into Auto Test menu. /// MENU 0 SYST
- 3 /// The indicator of is turned on after entering into enter into Auto Test menu. /// STATE 1 ON
- 4 /// Use Entry keys or the knob to set the State to On, and press "Enter" key to confirm. /// STATE 1 ON
- 5 /// Use "↑", "↓" keys to select the parameter end step. Use Entry keys or the knob together with "◀", "▶" keys to input the end step to 2, and press "Enter" key to confirm. /// END ST 2
- 6 /// Please refer to 6.4.1 operation steps, and set parameters according to table 4-B.
- 7 /// Press "Cancel" key to exit auto test parameter edit interface and enter into auto test waiting interface.

Table 7-B: +15V/2.3A parameter setting

Step	Mode	Level	Min	Max	Delay
0	CCL	0.000A	15.000V	16.000V	1s
1	CCL	2.300A	14.500V	16.000V	2s
2	CVL	15.000V	2.300A	5.400A	2s

3) Load C, to test -15V/0.5A

Procedures /// Operation Descriptions /// Display

- 1 /// Set the external TTL trigger as the load's trigger mode. /// SOURCE 1 Pulse
- 2 /// Press key to enter into Auto Test menu. /// STATE 1 ON
- 3 /// The indicator of is turned on after entering into enter into Auto Test menu. /// STATE 1 ON
- 4 /// Use Entry keys or the knob to set the State to On, and press "Enter" key to confirm. /// STATE 1 ON





5 /// Use “↑”, “↓” keys to select the parameter end step. Use Entry keys or the knob together with “◀”, “▶” keys to input the end step to 2, and press “Enter” key to confirm. /// END ST 2

6 /// Please refer to 6.4.1 operation steps, and set parameters according to table 4-C. ///

Table 7-C: -15V/0.5A parameter setting:

Step /// Mode /// Level /// Min /// Max /// Delay

0 /// CCL /// 0.000A /// 15.000V /// 16.000V /// 1s

1 /// CCL /// 0.500A /// 14.200V /// 16.000V /// 2s

2 /// CVL /// 14.500V /// 0.400A /// 0.600A /// 2s

After completing all the above settings, connect the power supply to the load’s input terminals according to Fig.7-1. The trigger signals of the three loads should be connected on the one key. Press the key to start testing, the first step is to test the rang of Voff point, the second step is to test the rang of Von point. When the test has been finished, remove the power supply and the load will enter into the waiting status.

7.4.3. Test Signal Terminal

For example: enable the auto test by testing signal terminal. Detailed operation steps as below:

Procedures /// Operation Descriptions /// Display

1 /// Set the external trigger as the load’s trigger mode. /// FUNCTI 0 Input; SOURCE 1 Pluse

2 /// Other test refers to 6.1 section. ///

After completing all the above steps, connect the test signal to load’s input terminal, input a trigger signal at test signal terminal, and then activate auto test. When the test is passed, the PASS signal outputs high level; When the test is failed, the FAIL signal outputs high level; in other states, the PASS signal and FAIL signal output low level.

8. Main Specifications

The warm-up time is 30 minutes. Specifications indicate warranted performance in the 25°C±5°C region of the total temperature range.

Rated input (0°C~40°C)

Voltage /// 0~150V

Current /// 1mA~30A

Power *1 /// 300W

MOV@FS current /// 0.82V

Constant voltage mode (CV)

Low range /// 0.1~30V

Resolution /// 1mV

Accuracy /// ±(0.05%+0.02%FS)

High range /// 0.10~150V





Resolution /// 10mV

Accuracy /// $\pm(0.05\%+0.025\%FS)$

Constant current mode (CC)

Low range /// 0~3A

Resolution /// 1mA

Accuracy /// $\pm(0.1\%+0.1\%FS)$

High range /// 0~30A

Resolution /// 10mA

Accuracy /// $\pm(0.1\%+0.15\%FS)$

Constant resistance mode (CR) (Input voltage /current \geq 10%FS)

Low range (VH CRL) /// $\approx 0.04\sim 6\Omega$

Resolution /// 100u Ω

Accuracy (Impedance) /// $\pm(0.5\%+0.5\%FS)$

Middle range (VH CRM) /// $\approx 6\sim 600\Omega$

Resolution /// 2.7us

Accuracy (Conductance) /// $\pm(1\%+1\%FS)$

High range (VH CRH) /// $\approx 60\sim 4000\Omega$

Resolution *2 /// 0.30us

Accuracy (Conductance) /// $\pm(1.5\%+1.5\%FS)$

Low range (VL CRL) /// $\approx 0.04\sim 1.12\Omega$

Resolution /// 18u Ω

Accuracy (Impedance) /// $\pm(0.5\%+0.5\%FS)$

Medium range (VL CRM) /// $\approx 1.12\sim 112\Omega$

Resolution /// 15us

Accuracy (Conductance) /// $\pm(1\%+1\%FS)$

High range (VL CRH) /// $\approx 11.2\sim 2000\Omega$

Resolution /// 1.6us

Accuracy (Conductance) /// $\pm(1.5\%+1.5\%FS)$

Constant power mode (CP) (Input voltage /current \geq 10%FS)

Range /// 0~300W

Resolution P<100W /// 1mW

Resolution P \geq 100W /// 10mW"

Accuracy /// $\pm(1\%+0.1\%FS)$

Voltage measurement

Low range /// 0~30V

Resolution /// 1mV

Accuracy /// $\pm(0.05\%+0.02\%FS)$

High range /// 0~150V



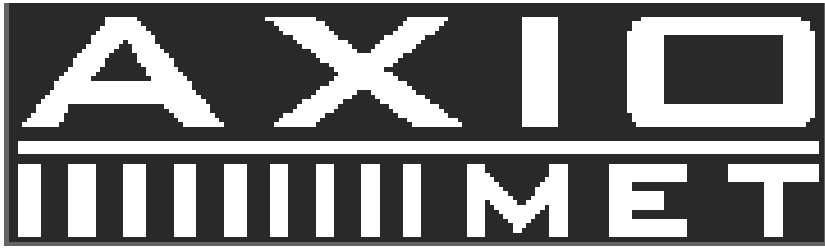

Resolution /// 10mV

Accuracy /// $\pm(0.05\%+0.025\%FS)$

Current measurement

Low range /// 0~3A

Resolution /// 1mA

Accuracy /// $\pm(0.1\%+0.1\%FS)$

High range /// 0~30A

Resolution /// 1mA

Accuracy /// $\pm(0.1\%+0.15\%FS)$

Power measurement (Input voltage /current \geq 10%FS)

Range /// 0~300W

Resolution P<100W /// 1mW

Resolution P \geq 100W /// 10mW

Accuracy /// 1%+0.1%FS

Current slew rate

Range CCH (/us) /// 0.1mA ~1.5A

Range CCL (/us) *3 /// 0.1mA ~0.15A

Resolution /// 0.1mA/us

Accuracy *4 /// 3%+10us

Battery discharge

Discharge time /// 1s~100h

Resolution /// 1s

Accuracy /// 0.2%+1s

Battery capacity /// 3000Ah

Resolution /// 1mAh

Accuracy /// 0.3%+0.01Ah

Discharge voltage range /// 0.1V~150V

Discharge current resolution /// 10mA

Short circuit

CCL /// 3.6A

CCH /// 33A

CV /// 0V

VH CRL /// 0.027 Ω

VH CRM /// 5.6 Ω

VH CRH /// 58 Ω

VL CRL /// 0.027 Ω

VL CRM /// 1.1 Ω

VL CRH /// 10 Ω





CPV /// 315W

CPC /// 0W

Max. slew rate

Current /// 1.5A /us

Voltage /// 0.2V /us

Open circuit /// $\geq 20k\Omega$

Max. input level

Current /// 33A

Voltage /// 175V

Ripple & Noise

Current (rms/p-p) /// 3mA/30mA

Voltage (rms) /// 5mV

Transient operation

Transient mode /// Continuous, Pulse, Toggled

Frequency range *5 /// 0.01Hz~2kHz

High/Low time /// 0~99999ms

Resolution /// 250us

Accuracy /// 0.2%+10us

Rising/Falling time /// 250us~99999ms

Resolution /// 250us

Accuracy /// 0.2%+10us

List Mode

Step time /// 10ms~99999s

Resolution /// 10ms

Accuracy /// 0.2c/o+10us

No. of steps /// 1~50

No. of cycles /// 0~65535

Storage /// 8 Lists

Expanded function /// Chain

Trigger input

Trigger level /// TTL falling edge

Trigger pulse width /// $\geq 20\mu s$

General

Protection /// Over current, over voltage, over power, over temperature and reverse voltage protections

Interface /// RS-232 interface, support SCPI commands, support Labview

Interface /// Optional RS-232 to USB cable

Operating environment /// 0°C~40°C, $\leq 85\%RH$

Storage environment /// -10°C~70°C, $\leq 70\%RH$

Power source /// AC110V/220V $\pm 10\%$ selectable, 50/60Hz





Accessories /// Power cord x1, Operation manual x1, RS-232 cable x1
Dimension (WxHxD) /// 215x89x412mm
Weight /// 6.7kg

9.

- *1. Maximum continuous power available is derated linearly from 100% of maximum at 40°C, to 75% of maximum at 50°C.
- *2. Conductance (S) = 1 / Resistance (Ω).
- *3. The set level is 10 times larger than the slew rate in CCL mode.
- *4. The actual transition time is defined as the time required for the input to change from 10% to 90% or from 90% to 10% of the programmed excursion.
- *5. Transient frequency depends on the time for high/low level and rising/falling edge.

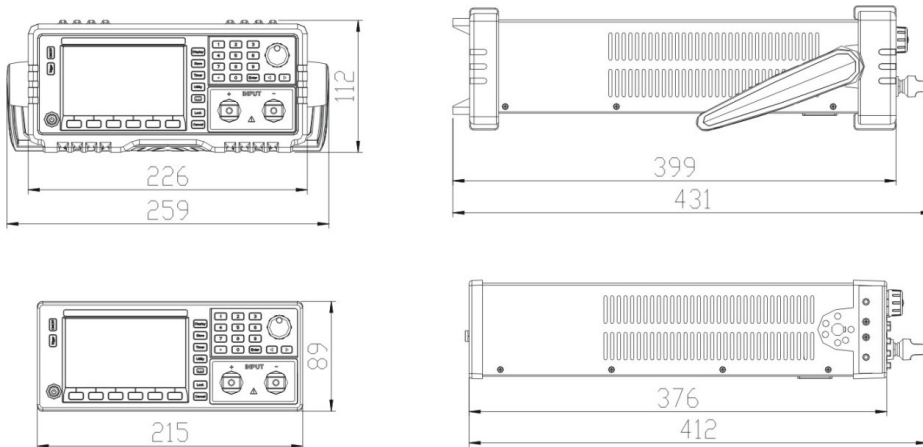

AXIOM

AXIOMET

EN

