

355 Nylon Cable Chain

Inner height (D) 30 mm

Double share single link joining construction with large anti-friction single-pin. Non-opening. Vertical separators are available. Due to its design with double-share lateral side, the chain is very robust, meanwhile offering very low friction. Used with guide channels, this chain is particularly suitable for long distance travel.

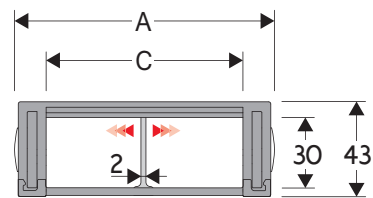

Separator*	
- Unassembled	Part.no S355
- Assembled	Part.no S355MC
Pin	
	Part.no PG355

*Separator not to be used in long-stroke applications

Technical characteristics when self-supported

Speed	10 m/s
Acceleration	50 m/s ²

For higher requirements please consult our technical dept.

A	B	C	D	R	Weight/m	Chain
mm	mm	mm	mm	mm	kg	Part Number
74	43	45	30	54	1,35	355044
74	43	45	30	75	1,35	355045
74	43	45	30	100	1,35	355046
74	43	45	30	150	1,35	355047
74	43	45	30	200	1,35	355048
94	43	65	30	54	1,45	355064
94	43	65	30	75	1,45	355065
94	43	65	30	100	1,45	355066
94	43	65	30	150	1,45	355067
94	43	65	30	200	1,45	355068
124	43	95	30	54	1,65	355094
124	43	95	30	75	1,65	355095
124	43	95	30	100	1,65	355096
124	43	95	30	150	1,65	355097
124	43	95	30	200	1,65	355098

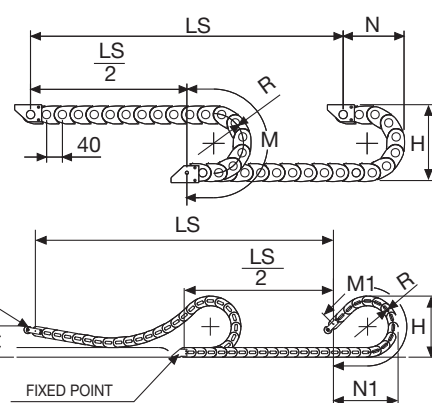

R	H	N	M	N1	M1
mm	mm	mm	mm	mm	mm
54	152	120	250	135	290
75	194	140	315	190	420
100	244	165	395	275	640
150	344	215	555	450	1075
200	444	265	710	620	1515

Length of chain (L)
Half travel distance ($\frac{LS}{2}$)
plus length of curve (M) or (M1)

$$L = \frac{LS}{2} + M \text{ or } M1$$

For sliding applications, technical data can slightly change according to frequency, added weight and environment.

SLIDING VERSION
to be ordered with pivoting end brackets set



Self-Supporting Capacity Diagram

The maximum length of the self-supporting capacity ($\frac{LS}{2}$) in relationship to the weight of the cables and hoses contained per linear metre.

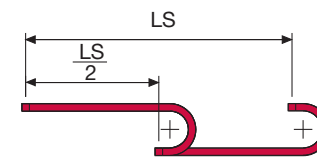
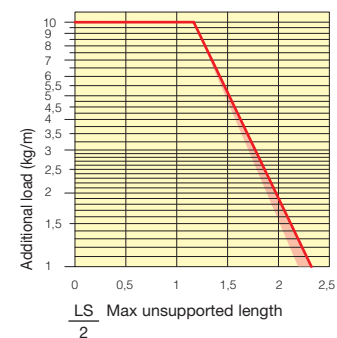

The red marking in the diagram area considers the difference of weight between various widths of chain.

For applications with $\frac{LS}{2}$ and weights not included in the area of the diagram showing self-supporting capacity, verify the possible use of support rollers (see page 30).

End Brackets

The end brackets set allows the two ends of the chain to be attached to the equipment.

Nylon Type

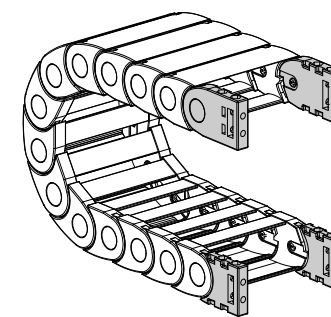

Fig. A
The chain can be fixed frontally, inner or outer radius. (Fig A)

Bright Zinc Plated Steel Type***

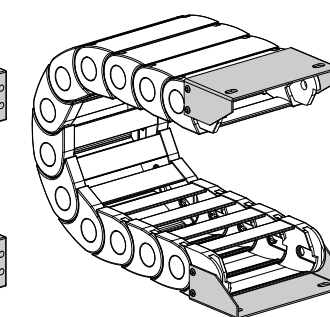
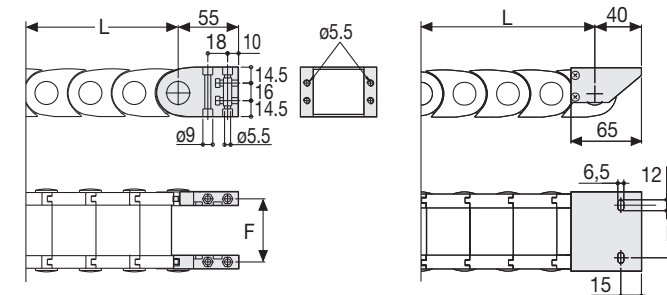

Fig. B
Chain fixed outside the radius. (Fig B)
See end brackets mounting variations page 31.



Chain Type	F mm
355 C=45	57
355 C=65	77
355 C=95	107

Nylon Type Part Numbers

Complete Set Assembled Chain Type	End Brackets Set
355 C=45	AN355KM
355 C=65	AN355KM
355 C=95	AN355KM

Complete Set Unassembled Chain Type	End Brackets Set
355 C=45	AN355K
355 C=65	AN355K
355 C=95	AN355K

Chain Type	F mm
355 C=45	50
355 C=65	70
355 C=95	100

Bright Zinc Plated Steel Type Part Numbers

Complete Set Assembled Chain Type	End Brackets Set
355 C=45	AP355KM□**
355 C=65	AM355KM□**
355 C=95	AG355KM□**

Complete Set Unassembled Chain Type	End Brackets Set
355 C=45	AP355K□**
355 C=65	AM355K□**
355 C=95	AG355K□**

** 1=Pos.1; 2=Pos.2; 3=Pos.3
*** Available on request in stainless steel

355 Nylon Cable Chain

Suitable to long travel distance. To choose the guide channel see page 82

Special tool to remove the connecting pivots: Part Number PZ010.



For further information please consult Brevetti Stendalto's Technical Office