

013B9

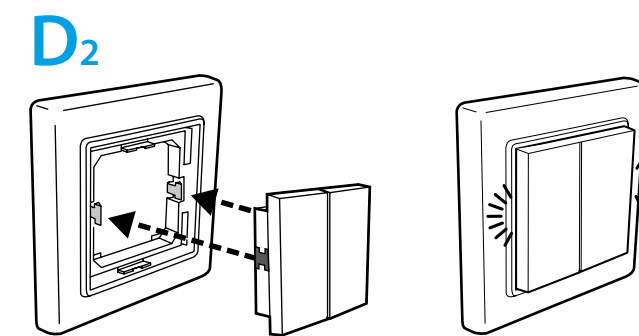
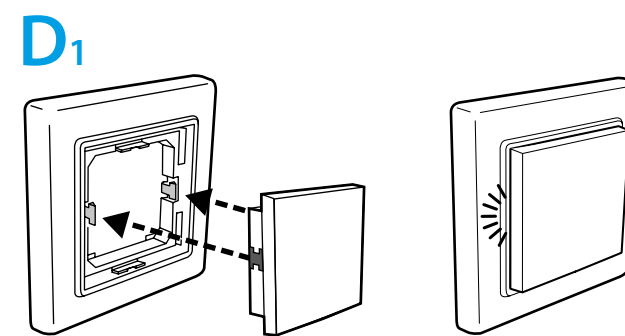
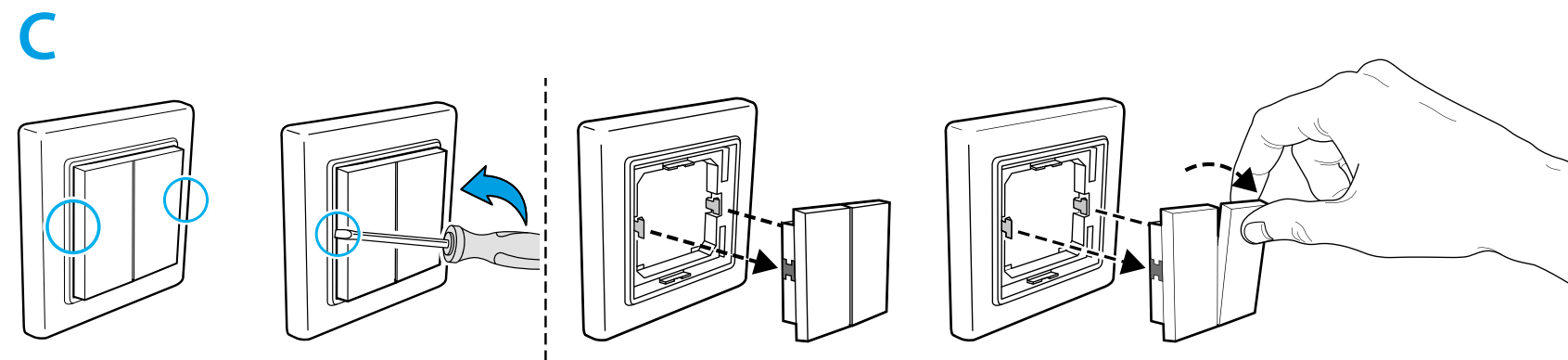
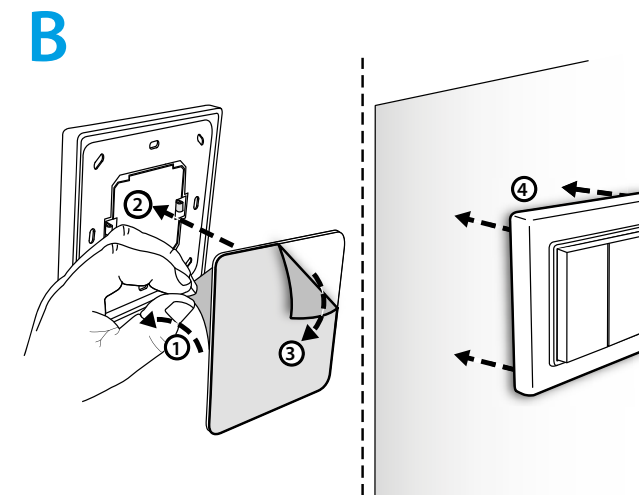
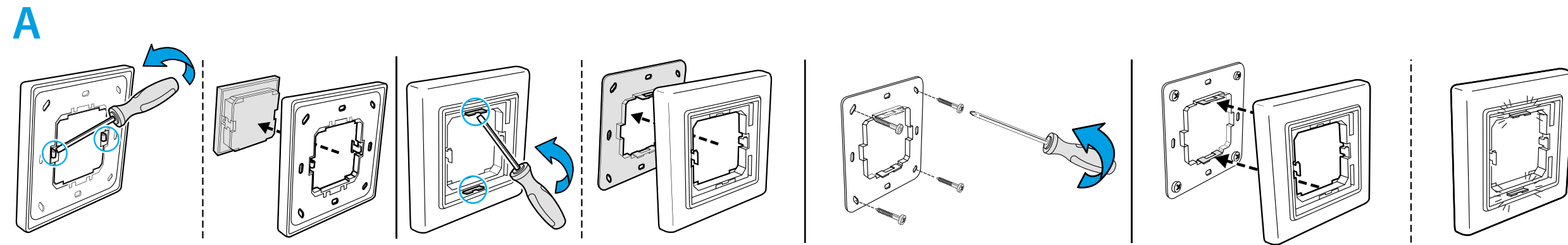

# ENGLISH

## Wall mounting switch BLE 013B9

- A Fixing to a wall or to a junction box (with screws)
- B Fixing to a wall (with adhesive)
- C Demounting push buttons
- D1 Mounting a single push button
- D2 Mounting a double push button

### Compatible plates

The frame of the BLE 013.B9 switch can be replaced. See the following table

Producer	Type
BERKER	S1, B1, B3, B7 Glas
GIRA	Standard55, E2, Event, Esprit
Jäger Direkt	Opus Inform, Kubus, Fusion
JUNG	A500, Aplus
MERTEN	M-Smart, M-Arc, M-Plan

### TRANSMISSION RANGE

- Transmission range: approximately 10 m in free space and without obstacles
- The transmission range may vary depending on the building structure

### Example:

- Reinforced concrete walls and/or metal walls
- Switch mounted on a metal surface or in metal frames
- Partition walls filled with insulating wool on a metallic backing
- Ceilings with metal or carbon fiber panels
- Lead glass or glass with metal cladding, steel furniture

### TECHNICAL SPECIFICATIONS

Source of energy	Integral self powered generator
Operating frequency	2.4 Ghz Bluetooth BLE
Approvals	2.4 Ghz: CE, FCC, IC (Europe, US, Canada)
Switching cycles	min. 50.000
Operating temperature	-25°C ... +65°C

### Information

- Switch 013.B9 is intended for internal use
- The product is not suitable for environments with high vibration, mechanical shock, very high humidity, very dusty or in an explosive atmosphere

### Safety instructions

- Choking hazard! Do not leave packaging material around. Children could swallow the smaller parts and choke
- Install and use the product according to the manual provided and do not modify the product in any way
- Improper cleaning can damage the product. We recommend cleaning with a soft and damp cloth